

Contact Us:

Phone

Office (719) 633-3811
Fax (719) 633-3496
Tech Support Line (Toll Free) (866) 365-2762

Web

<http://www.snowperformance.net>

Email

sales@snowperformance.net
customerservice@snowperformance.net
tech@snowperformance.net

Mail

Snow Performance, Inc
1017-A East Highway 24
Woodland Park, CO 80863

INSTALLATION INSTRUCTIONS FOR PART #48002 WATER / METHANOL INJECTION SYSTEM DURAMAX 6.6L DIESEL

Notes

The contents of this document are subject to change without prior notice. No part of or this entire document may be reproduced in any form without prior written permission of Snow Performance, Inc under the copyright except for private use.

The names, addresses and telephone numbers mentioned are current as of November 1, 2009. Note that this information is subject to change. Please refer to www.snowperformance.net for current information.



CONTENTS

Kit Contents	3
Introduction	4
Nozzle Identification Chart	4
Installation – Mechanical	5
Installation – Electrical	10
Variable Controller Installation	10
Variable Controller Tuning	11
Controller Operation Example	12
Testing the System	12
Tuning Quick Reference	13
Maintenance	14
Fluid Level Switch	15
Solenoid Upgrade (optional)	16
Install Notes	17
Warranty Information	18
Contact Us	22

Have a question?

FAQ: www.snowperformance.net/faqs.php

 **CAUTION**

You must completely read through these instructions before installing and operating this product. Failure to do so can result in damage to this product and the vehicle.

LIMITATION OF LIABILITY

REPAIR OR REPLACEMENT OF A DEFECTIVE PRODUCT IS THE ORIGINAL RETAIL PURCHASER'S EXCLUSIVE REMEDY UNDER THIS WARRANTY. DAMAGE OR INJURY TO THE ORIGINAL RETAIL PURCHASER, TO HIS OR HER VEHICLE, CARGO, OR PROPERTY, AND/OR TO ANY OTHER PERSON OR PROPERTY IS NOT COVERED BY THIS WARRANTY. THIS WARRANTY IS EXPRESSLY MADE IN LIEU OF ANY AND ALL OTHER EXPRESS WARRANTIES, WHETHER ORAL OR WRITTEN. SNOW'S SOLE LIABILITY IS LIMITED TO THE REMEDY SET FORTH ABOVE. IN NO EVENT WILL SNOW BE LIABLE FOR ANY DIRECT, INDIRECT, CONSEQUENTIAL, INCIDENTAL, SPECIAL, EXEMPLARY, OR PUNITIVE DAMAGES OR FOR ANY OTHER DAMAGES OF ANY KIND OR NATURE (INCLUDING, BUT NOT LIMITED TO, LOST PROFITS OR LOST SALES). SOME STATES DO NOT ALLOW THE EXCLUSION OR LIMITATION OF INCIDENTAL OR CONSEQUENTIAL DAMAGES, SO THE ABOVE LIMITATIONS MAY NOT APPLY TO YOU.

Non-Warranty Repair/Retest

Products returned due to damage or misuse and Products retested with no problem found are subject to repair/retest charges. Product will be returned to customer at customer's expense. A credit card number must be provided in order to obtain an RMA (Return Merchandise Authorization) number prior to returning Product.

Warranty

Warranty Policy

Snow Performance, Inc. warrants that the Product shall conform to and perform in accordance with published technical specifications and shall be free of defects in materials and workmanship for 90-days providing:

1. You are the original purchaser and provide proof of purchase.
2. For 1-year warranty, the Warranty Card that came with system (not applicable to separate parts purchases) is returned to Snow within 45-days of purchase. If valid warranty card not on file with Snow, the standard 90 day warranty applies from date of purchase.
3. For Lifetime warranty, the Warranty Card that came with system (not applicable to separate parts purchases) is returned to Snow within 45-days of purchase and Boost Juice® injection fluid is used exclusively.*
3. An RMA # has been attained and is displayed on package containing returned part.
4. Parts Warranty ~ 90 day warranty on parts purchased separately if used in conjunction with a Snow System. No warranty implied if used with a non-Snow part/system.

Subject to Snow's inspection of the product, Snow will remedy defects in materials and/or workmanship by repairing or replacing, at Snow's option, the defective product without charge for parts or labor, subject to the limitations and exclusions described in this warranty.

This warranty does not cover problems caused by normal wear and tear including aesthetic oxidation of surfaces, accidents, unlawful vehicle operation, or modifications or repairs to product not performed or authorized by Snow. This includes any product that is disassembled or taken apart for any reason.

* Boost Juice® usage evidenced by invoices/ receipts.

In addition, this warranty does not cover problems resulting from conditions beyond Snow's control including, but not limited to, theft, misuse, overloading, or failure to assemble, mount or use the product in accordance with Snow's written instructions or guidelines included with the product or made available to the original retail purchaser.

In the event of failure, Snow will repair or replace the part at Snow's sole discretion. Failures resulting from misapplication or misuse of the Product, failure to adhere to any specifications or instructions, or failure resulting from neglect, abuse, accidents, or act of nature are not covered under this warranty.

Warranty service may be obtained by calling 719-633-3811, getting an RMA (Return Merchandise Authorization), delivering the part to Snow along with proof of purchase. Customer agrees to insure the Product or assume the risk of loss or damage in transit, to prepay shipping charges to Snow, and to use the original shipping container or equivalent. Shipping for Warranty replacement parts shipped outside the continental US will be charged to customer.

Non-Warranty Repair/Retest

Products returned due to damage or misuse and Products retested with no problem found will be returned to customer at customer's expense.

Kit Contents

Parts

- UHO Pump (Ultra High Output)
- 3 Qt Reservoir
- 10 ft High Pressure Tubing
- 3 ft Black Wire Loom
- 18" 1/8" Silicone Tubing

Electrical Packet

- 1 Green LED
- 2 Blue Butt Connectors
- 2 Small Eyehooks
- 1 Large Eyehook
- 1 Male Connector
- 3 Female Connectors
- 1 Arm Switch
- 1 Boost 'T'
- VC-100 Controller With Wiring Harness
- 10 Tie Wraps
- Fuse holder
- 20 amp fuse

Required Tools

Electric Drill w/ Drill Bits
Utility Knife
Screwdriver – Phillips
Assorted Wrenches
1/8" – 27 NPT Tap

Mechanical Packets

- 1 Nozzle Holder
- 1 3/8" NPT to 1/4" tube
- 8 #8x1&1/2" Screws
- 8 #8 Washers
- 4 #6x1/2" Screw
- 1 Dual Nozzle Upgrade
- 1 Bulkhead
- 1 E-6000® (GOOP)
- 1 375 Nozzle
- 2 625 Nozzles

Upgrades/Options

- 2.5 Gallon Reservoir
- 7 Gallon Reservoir
- Solenoid Upgrade
- Hose Adaptor or Bung
- Boost Juice
- Level Switch

Introduction

This kit progressively injects water-methanol according to manifold boost pressure. The system is applicable for turbo diesels making over 25 psig of boost pressure. The controller utilizes a heavy-duty design that can read up to 100 psig of boost. It has two dials to set the start and full points to tailor the delivery to your engine's needs. Progressively injecting according to boost pressure allows for the most power over the widest range of RPMs. These kits allow for great horsepower increases and EGT reductions – expect about 70hp and 250 degree F EGT drop using a 50% mixture of water/methanol. Please refer to the system diagram during install.

Nozzle Identification Chart:

Nozzle Number	Nozzle Size	Nozzle Color	Nozzle Size
1	60 ml/min	4	225 ml/min
2	100 ml/min	5	375 ml/min
3	175 ml/min	6	625 ml/min

Install Notes

Pump Setting _____(psig)

Nozzle Size _____(ml/min)

Boost / Vacuum setting _____

Misc:

Disclaimer

Do not use this product until you have carefully read the following agreement. This sets forth the terms and conditions for the use of this product. The installation of this product indicates that the BUYER has read and understands this agreement and accepts its terms and conditions. Performance products by their nature are designed to increase horsepower and performance not engineered in the original vehicle and the increased stress could result in damage to related systems. This is a high performance product – use at your own risk. Snow Performance Inc., Its agents, employees or owners shall not be under any liability whether in contract or otherwise whether or not resulting from our negligence or contents of information supplied for any damage or loss resulting from such information. The BUYER is responsible to fully understand the capability and limitations of his/her vehicle according to manufacturer specifications and agrees to hold the SELLER harmless from any damage resulting from failure to adhere to such specifications. The SELLER disclaims any warranty and expressly disclaims any liability for personal injury or damages. The BUYER acknowledges and agrees that the disclaimer of any liability for personal injury is a material term for this agreement and the BUYER agrees to indemnify the SELLER and to hold the SELLER harmless from any claim related to the item of the equipment purchased. Under no circumstances will the SELLER be liable for any damages or expenses by reason of use or sale of any such equipment. The BUYER is responsible to obey all applicable federal, state, and local laws, statutes, and ordinances when operating his/her vehicle, and the BUYER agrees to hold SELLER harmless from any violation thereof. The SELLER assumes no liability regarding the improper installation or misapplication of its products. It is the installer's responsibility to check for proper installation and if in doubt, contact the manufacturer.

Solenoid Upgrade (optional)

The optional Solenoid Upgrade (#40060) is required if the nozzle is to be installed after the intake throttle plate (as shown), or the fluid reservoir is mounted higher than the nozzle. It is highly recommended for trunk-mount reservoirs.

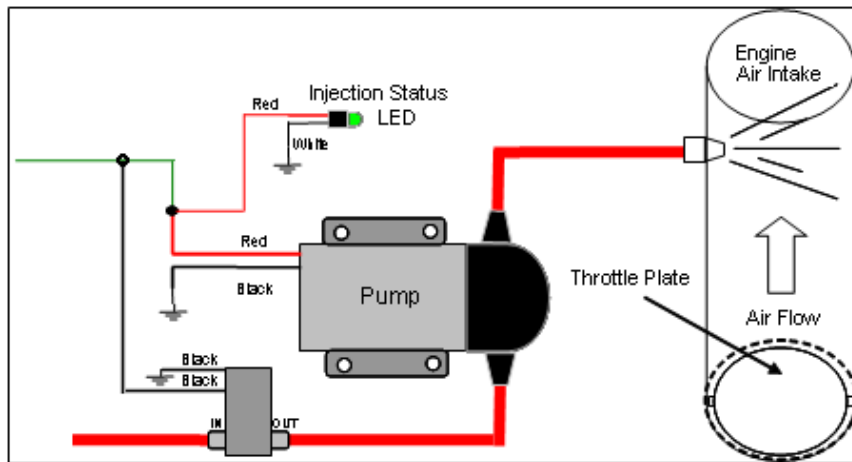

Finger thread the two 1/8" NPT quick connect fittings into ports labeled (2 or IN) and (1 or OUT) on the solenoid. Tighten an additional half turn past finger tight.

Note: Solenoid must be installed Pre-pump to ensure correct operation.

Cut high pressure line at location solenoid is to be installed. Insert ends of cut line into quick connect fittings of solenoid. The port labeled (2 or IN) is the inlet and the port labeled (1 or OUT) is the outlet. Gently pull on line to check secure connection. If line pulls out, re-insert farther into fitting to engage locking clips. If high pressure line removal is required, firmly press in metal fitting ring to disengage locking clips while pulling hose from fitting.

Connect one of the BLACK wires from solenoid to the RED positive pump wire or the WHITE wire from the controller. Note that connecting the wire to any other power source other than the pump/controller wire will result in improper operation of solenoid. Connect the second BLACK wire to a secure chassis ground location.

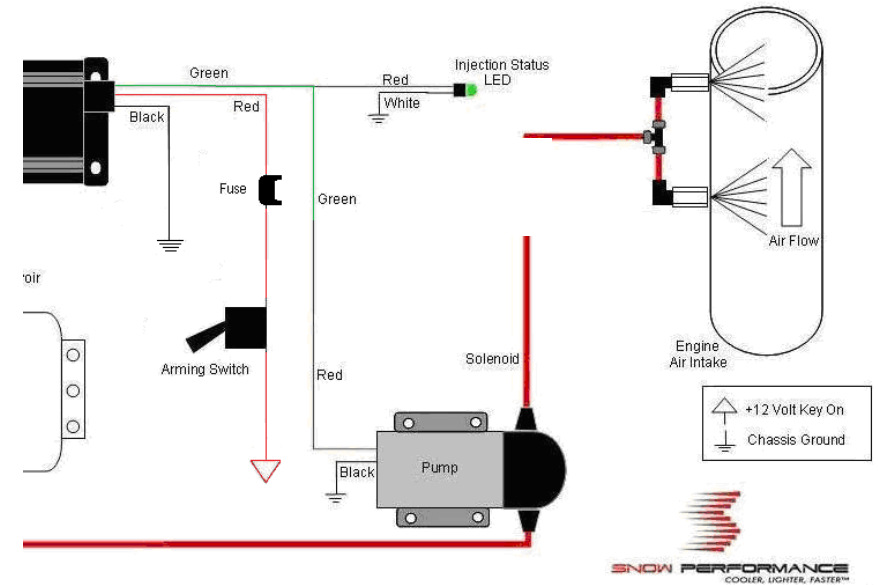

The included rocker switch has 2 prongs. The prong with the piece of plastic coming out with it is connected to 12VDC key on power, while the other prong connects to the RED controller wire. Note that while the diagram shows both nozzles, often only one is needed. See page 8 for details.

Installation - Mechanical

Step 1 Reservoir Install

Install straight fitting with some included E6000® sealant and mount reservoir as high in engine compartment as possible using #8x1 1/2" sheet metal screws and washers provided. Note that the nozzles should be the highest point in the system, not the reservoir.

Optional: The factory windshield washer reservoir can be used as the reservoir for your system.



Bulkhead Fitting Installed in Washer Tank.

- Drill 9/16" hole in desired bulkhead location.
- Remove one nut from bulkhead and turn the remaining nut until it is at the very end.

- Feed red tubing through the drilled hole and up and out of the top of the reservoir.
- Attach tubing to the bulkhead on the side opposite the nut.
- Pull the tubing through the bulkhead hole until the bulkhead seats against the inside of the reservoir.
- Apply a liberal amount of E6000® sealant (included) around bulkhead.
- Slide the nut you had previously removed up onto the tube and thread onto bulkhead.
- While pulling firmly on the red tubing, tighten the outer nut using a 17mm socket (only needs to be hand tight). A ratchet is not needed.
- Once sealant has set, fill reservoir with water and check for leaks.

Caution*****

To avoid gravity feeding of fluid with rear mount reservoirs, it is essential to use a check valve in-line between the reservoir and pump. **Do not operate** your rear mount equipped vehicle without a check valve installed.

Step 2 Pump Install

Mount the pump so the inlet is positioned at the lowest point of the reservoir or lower. Pump can be mounted horizontally or vertically using the supplied screws and washers. Ensure that no sharp bends in the high pressure tube occur near the pump. Sharp bends can cause stress on the inlet and outlet ports of the pump, causing leaks. Trim tube with a utility knife or razor blade, making sure to eliminate any burrs or kinks on the end. Insert firmly into the pump about ½ inch through the light grey locking collar. Note the arrows indicating flow direction on the top of the pump. To remove the hose, gently and evenly push the light grey locking collar into the head unit of the pump, then pull on the hose gently.

Fluid Level Switch (optional)

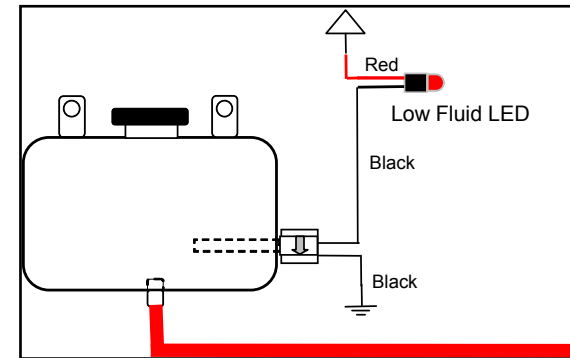

Instructions

- Locate desired level switch mounting position. Suggested placement is 1/5 of max reservoir height.
- Carefully drill side of reservoir using 13/16" bit. A step bit is recommended for best drilling results. Hole must be free of nicks or shavings for proper sealing.
- Remove rubber seal from level switch. Insert seal into reservoir until fully seated. Goop can be used around the edges of the hole.
- Lubricate exterior of level switch with water and insert into seal until fully seated. Position level switch so **GT** symbol is at six o'clock position.
- Wait 30 minutes for Goop to cure, then test for leaks. With fluid level above level switch, float should be angled up. With fluid level below level switch, float should be in horizontal position.
- Connect one black wire from level switch to ground.
- Connect other black wire from level switch to white wire from LED.
- Connect red wire from LED to +12 volt key on power source.



1. The engine be run without water/methanol for at least 5 minutes after injection before turning the engine off.

2. The “armed switch” is turned to the off position when the engine is off.

Caution: Do not attempt to inject water/methanol until the engine has reach operating temperature. A cold engine is more susceptible to quench and poor performance.

Caution*****

Prolonged quench may cause lower engine damage over a period of time.

Maintenance – Remove nozzle(s) and clean screen filters at least once per year using carb cleaner.

The Boost Cooler® has been designed to operate with high concentrations of methanol. Oil or other additives are not required for system lubrication.

For best performance, cooling and system life it is recommend that Snow Performance Boost Juice (#40008) be the exclusive fluid used in the system.



Measure the distance from the reservoir outlet to the pump inlet. Cut the ¼” red tubing using utility knife. Make cuts are as square as possible.

Ensure there are no kinks in the tubing and insert tubing into quick disconnects at pump and reservoir until fully seated. Keep the pump within 2 feet of the reservoir.

Caution*****

Pump must be shielded from road debris and tire wash. Failure to do so will result in pump failure

Step 3 Nozzle Selection

Nozzle sizing is a function of horsepower, which approximates the engine airflow, and boost, which approximates intake charge heat.

Recommended starting points:

250 - 400 WHP	625 ml/min nozzle
425 - 525 WHP	375 & 625 ml/min nozzle
550 - 650 WHP	2 X 625 ml/min nozzle

TECH TIP Seal the nozzle into the nozzle holder using included GOOP® sealant. Using a sealant that is not permanent will allow for nozzle changes during tuning. Simply remove the nozzle, clean the threads, and reinstall using sealant.

Assemble desired nozzle into nozzle holder using E6000® sealant. The end of the nozzle with the fine mesh screen is to be inserted into the nozzle holder. Torque 1/2 turn past finger tight. Do not use Teflon sealants on Snow Performance fittings.



Correct



Incorrect

NOTE: If nozzle is mounted lower than the reservoir, a Solenoid Upgrade (#40060) must be used to prevent draining.

If pump goes on and fluid level doesn't go down, there is an obstruction in the tube or nozzle.

Activation of pump for short periods (1 - 5 sec.) will purge air bubbles from the system after installation. This can be accomplished during initial use.

Step 2 Test Controller

- Begin the testing process with both dials on the variable controller at their lowest settings (counter-clockwise).
- Turn ignition key on so that the system has 12 volt power. If the pump runs, inspect ground wires for secure connection.
- Pump should be off at this point, apply light air pressure into vacuum tube connection on back of controller. Pump should activate while low pressure is applied but not enough to completely atomize fluid.

Tuning Quick Reference

If combustion quench occurs as evidenced by engine “bucking”, reduce the injection quantity or raise the onset boost level. This can be done by:

1. Using a smaller nozzle(s).
2. Introducing injection later at a higher start setting.

Also, fresh methanol – less than 1 month old when exposed to atmosphere – and using a greater methanol concentration – up to 50% - will reduce combustion quench.

100% water will cool combustion and EGTs and will increase power approximately 20-30 HP.

75/25% water/methanol will cool EGTs and power will increase approximately 40-60 HP.

50/50% water/methanol will cool EGTs and increase power approx 70+ HP.

Caution: To avoid “pooling” in the intake and possible engine damage upon start-up, it is recommended that:

For the middle line, the chart shows the Start dial at 6 psi and the Full dial at 13 psi. At 6 psig of boost pressure the pump will operate at 10%. At 13 psig of boost pressure, the pump will deliver 100% of injection pressure.

For boost pressure readings between the Start and Full settings, the controller will linearly adjust the pump pressure as shown on the graph.

Testing the System

Note: for best results, prime pump before use

To clear air from the pump and insure that the system is primed:

- Fill reservoir with water approx ¼ full.
- Remove tubing from nozzle (or solenoid if solenoid used in-line between pump and nozzle) and run tube into separate container.
- Apply 12 VDC to red pump wire for approximately 5 seconds or until fluid flow is consistent.
- Pump is now primed. Reconnect tubing from pump outlet to nozzle (or solenoid).

If using a check valve in between the pump and the reservoir:

Remove the check valve and place a solid piece of tube between the pump and the reservoir and prime the system. Then replace the check valve in between the pump and reservoir.

Step 1 Test Pump and Mechanical System

Disconnect pump from controller. Using a 12 volt source, apply power to red wire of pump. Pump should activate, green LED should go on, and fluid level in tank should go down. It is recommended to also check the nozzle spray pattern while following this procedure. Also check for leaks.



Step 4 Nozzle Mounting

The nozzle assembly should be installed 90° to the direction of airflow. On round intake tubes, this is 360° around the tube meaning the nozzle can be mounted in any direction. This will ensure maximum cooling as the nozzle sprays in a cone pattern. Choose and mark mounting location for nozzle placement. Nozzles can be mounted virtually anywhere on the tube going from the intercooler outlet to the intake inlet, so long as it has a clear spray pattern into the tube and airflow. Ensure that the tip of the nozzle is flush with the inner wall of the tube or protruding slightly into the airflow.

Remove the selected piece before the intake and drill and tap (11/32" pre-drill, 1/8"-27 NPT tap) for one or two nozzles.



The nozzle is mounted using its external 1/8 NPT threads. Tighten the nozzle and nozzle holder assembly one half turn past finger tight using E6000® sealant on the threads.

Step 5 Nozzle Connection

Measure the distance from the pump outlet to the nozzle holder. Cut the ¼" tubing using utility knife. Make cuts are as square as possible.

Ensure there are no kinks in the tubing and insert tubing into quick disconnects until fully seated. Gently pull on tubing to ensure a good connection.

Installation - Electrical

Variable Controller Installation



The figure above shows the back view of the variable controller. Attach controller to secure location with easy access in engine bay or passenger compartment. The VC series controllers are designed to withstand engine bay conditions, but should not be mounted directly to the engine block. Connect vacuum/boost hose from intake plenum boost line (use the included boost 'T') to hose barb on back of controller and secure with a tie wrap. Plug wire harness into back of controller. Note the terminal positions are numbered on the bottom side of wire harness connector.

CAUTION: Disconnect the negative battery terminal while connecting wires to prevent electrical fire or damage to controller.

- Connect BLACK wire to a good ground location.
- Connect GREEN wire at position 1 to Pump RED power wire. Connect green LED per wiring diagram.
- Connect RED wire to inline switch and connect to a +12V key on source



Always have a good electrical ground connection. Poor ground will result in erratic operation of controller.

Variable Controller Tuning



- Use a tie wrap to keep silicone vacuum/boost line on hose barb in high boost applications.
- Adjust the "Start Psi" boost level first by turning dial clockwise to 1/3rd to 1/2 the engines max boost output. This sets the boost pressure required to activate the injection system. Typical start points are between 12 and 25 PSI.
- Next, adjust "Full Psi" to the engines max boost output.
- Note - over lapping the settings, where the Full dial is lower then Start, will result in max injection at the onset point.

A typical application making 35 psig of boost should set the start at about 18 and the full at about 30.

Controller Operation Example

