

banks

with Installation Instructions
Owner's Manual

Banks Ram-Air® Intake System

1994-2002 Dodge 5.9L Cummins

THIS MANUAL IS FOR USE WITH KIT 42225

Gale Banks Engineering
546 Duggan Avenue • Azusa, CA 91702
(626) 969-9600 • Fax (626) 334-1743

Product Information & Sales: (888) 635-4565
Customer Support: (888) 839-5600
Installation Support: (888) 839-2700

bankspower.com

banks

General Installation Practices

Dear Customer,

If you have any questions concerning the installation of your Banks Ram-Air System, please call our Technical Service Hotline at (888) 839-2700 between 7:00 am and 5:00 pm (PT). If you have any questions relating to shipping or billing, please contact our Customer Service Department at (888) 839-5600.

Thank you.

1. For ease of installation of your Banks Ram-air intake system, familiarize yourself with the procedure by reading the entire manual before starting work. This manual contains 16 pages of copy, illustrations and parts listing. If any pages are missing from this manual please call Gale Banks Engineering immediately for a replacement.

2. The exploded view of the Ram-Air assembly (pages 4-5) provides only general guidance. Refer to each step and section diagram in this manual for proper instruction.

3. Throughout this manual, the left side of the vehicle refers to the driver's side, and the right-side to the passenger's side.

4. Disconnect the ground cable from the battery before beginning work. If there are two batteries, disconnect both.

5. Route and tie wires and hoses a minimum of 6 inches away from exhaust heat, moving parts and sharp edges. Clearance of 8 inches or more is recommended where possible.

6. During installation, keep the work area clean. If foreign debris is transferred to any Banks system component, clean it thoroughly before installing.

7. When raising the vehicle, support it on properly weight-rated safety stands, ramps or a commercial hoist. Follow the manufacturer's safety precautions. Take care to balance the vehicle to prevent it from slipping or falling. When using ramps, be sure the front wheels are centered squarely on the topsides; put the transmission in park; set the parking brake; and place blocks behind the rear wheels.

Caution! Do not use floor jacks to support the vehicle while working under it. Do not raise the vehicle onto concrete blocks, masonry or any other item not intended specifically for this use.

Notification

The Banks Ram-Air Filter comes pre-oiled and no oiling is necessary for initial installation. Service the filter as specified in the Filter Maintenance Section of this manual.

Tools Required:

- 10mm socket wrench
- Phillips head screwdriver
- 5/16 in nut driver
- Clean shop towels or rags

Table of Contents

Section 1	4
General Assembly	
Section 2	6
Ram-Air Installation	
Section 3	10
Filter Maintenance	

Section 1

GENERAL ASSEMBLY

Figure 1

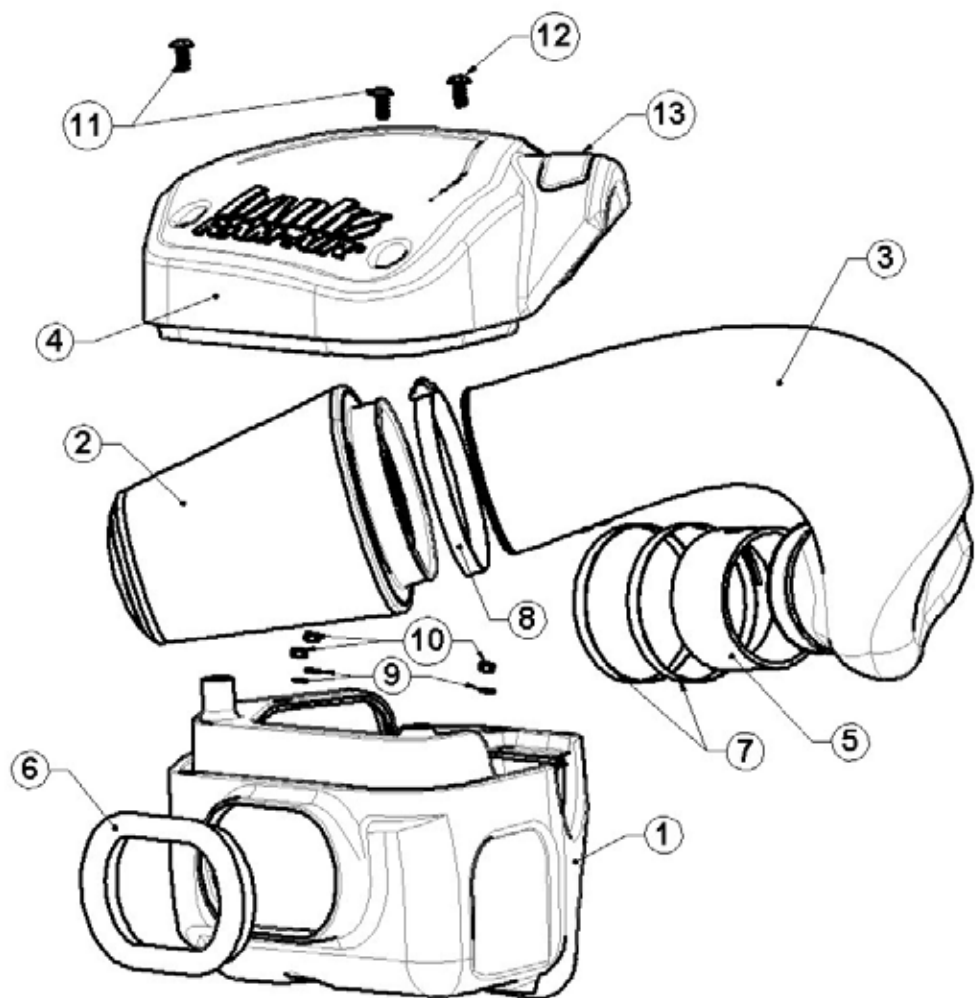

Bill Of Materials

P/N	Item	Description	QTY
42226	1	Housing, Ram-Air Filter	1
42188	2	Air Filter Element, Ram-Air System	1
42228	3	Intake Tube, Ram-Air	1
42227	4	Cover, Ram-Air Housing	1
94317	5	Hose, Compressor Inlet	1
93141	6	Edge-Grip Seal	1
92864	7	Hose Clamp, #64	2
92904	8	Hose Clamp, #104	1
91700	9	Washer, 6mm	3
91711	10	Nut, Nylock 6mm	3
91226	11	Screw, Phillips 3/4"	2
91241	12	Screw, Phillips 1.0"	1
97170	13	Decal, Banks Ram-Air	1

Section 2

RAM-AIR INSTALLATION

Use the Bill of Materials Chart and the General Assembly Drawing to reference component nomenclature and location. Use caution when working in the engine compartment. Make sure the engine has been OFF for several hours and cool.

You are about to install the Banks Ram-Air Intake System. Read and follow all steps before working on the vehicle. Some components from the stock air intake system will remain in service. Take care when removing stock air intake components to not damage them.

- 1.** Loosen hose clamp on stock intake tube at turbo charger compressor connection. See **figure 2**
- 2.** Unclamp stock airfilter lid and remove lid and tube from vehicle. See **figures 2,3**
- 3.** Remove air filter.

4. Loosen the 3 plastic retaining nuts and remove stock airfilter housing from vehicle. See **figure 4**

5. Connect edge grip seal (item 6) onto Banks Filter Housing (item 1). See **Figure 5**.

6. Install Banks Filter Housing (Item 1) into vehicle using the supplied washers and 6mm lock-nuts (Items 9,10).

7. Install the hose (Item 5) and two hose clamps (Item 7) onto the Banks intake tube (Item 3) where it will attach to the turbocharger compressor.

8. Install Banks filter hose clamp (Item 8) onto the Banks filter cuff (Item 2). Place Banks Filter into Banks filter housing.

9. Install the Banks Intake tube onto the turbocharger compressor, do not tighten hose clamps at this time.

Figure 2- Removal of Stock intake

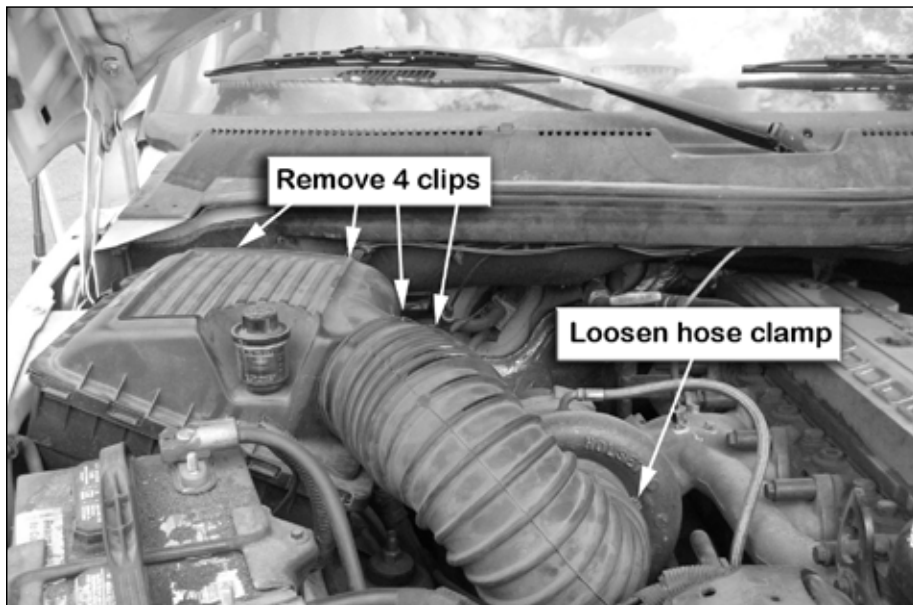

Figure 3- Removal of Lid and Tube



Figure 4- Removal of filter housing bottom

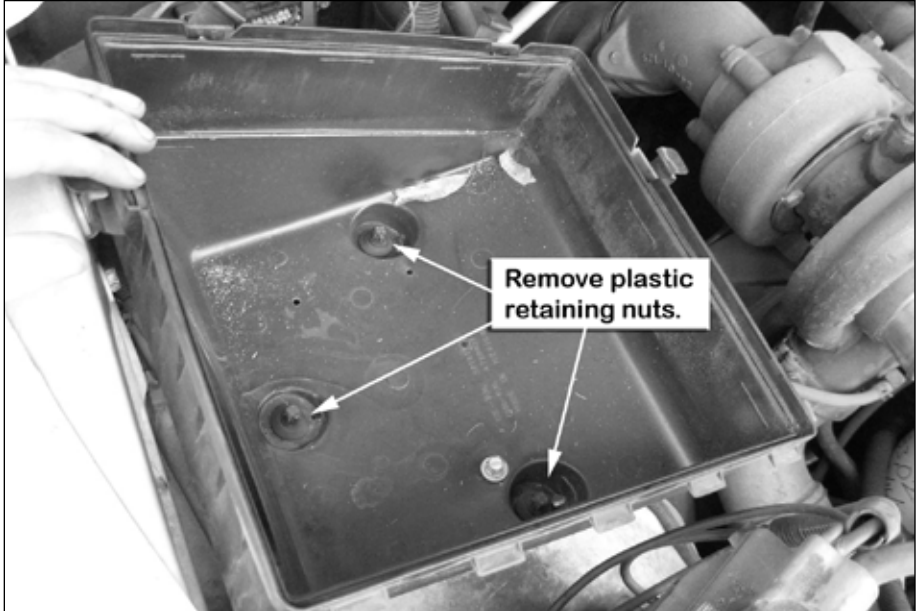

Figure 5- Attachment of Edge Grip Seal



10. Attach Banks Filter onto Banks intake tube. See **Figure 6**.

11. Align Banks tube and filter to fit correctly into Banks filter housing. Tighten hose clamps at filter and turbocharger compressor connections.

12. Place Banks Cover onto Ram-Air Housing and fasten with the 3 supplied Phillips head screws, with the 2 shorter screws placed near the engraved "Banks Ram-Air" logo.

12. You have successfully completed the installation of the Banks Ram-Air Intake system. Make sure to go over all hose clamps for tightness and connectors for a sure fit. Make sure that the intake tube is not touching any engine components.

-END, SECTION 2-

Figure 6- Connect Banks Filter to Tube



Figure 7- Installed Banks Ram-Air Intake System



Section 3

FILTER MAINTENANCE

Notification

The Banks Ram-Air Filter comes pre-oiled and no oiling is necessary for initial installation. Service the filter as specified in steps 1-2.

1. Service Banks Ram Air Filter every 50-100,000 miles on street-driven applications. Service more often in off-road or heavy-dust conditions.

2. Use Banks Ram Air Filter cleaning system (part # 90094), available from Gale Banks Engineering to service the Air Filter. Follow the instructions included with the cleaning system to clean and re-oil your Banks Ram Air Filter. No gasoline cleaning, No steam cleaning, No caustic cleaning solutions, No strong detergents, No high pressure car wash, No parts cleaning solvents. Any of these No's can cause harm to the cotton filter media plus SHRINK and HARDEN the rubber end caps.

CAUTION! Extremely fine dust from agriculture or off-road use will pull the oil from the element. Frequent re-oiling of the element's clean side might be required. Completely service when practicable. For extra protection use an air-filter sealing grease on rubber ends of the element. Service only with Banks Ram-Air-filter cleaner and Banks Ram-Air-filter oil.

-END, SECTION 3-

Notes

Gale Banks Engineering
546 Duggan Avenue • Azusa, CA 91702
(626) 969-9600 • Fax (626) 334-1743

Product Information & Sales: (888) 635-4565
Customer Support: (888) 839-5600
Installation Support: (888) 839-2700

bankspower.com