



**DOWNLOAD THE LATEST  
INSTALL MANUALS AT  
[www.bddiesel.com](http://www.bddiesel.com)**



# **BD Duramax Screamer Turbo**

## **Drop-in Turbo Replacement**

<b>Part #</b>	<b>Compressor Size</b>	<b>Model years</b>
<b>1045840</b>	<b>65 mm</b>	<b>2004.5-2010 Duramax LLY, LBZ, LMM</b>
<b>1045830</b>	<b>64 mm</b>	<b>2011-2016 Duramax LML</b>

LLY trucks require vane position adapter PN: 771864-0001.

1045830 meets CARB requirements for the following models: 2011-2016 2500/3500 6.6L Diesel Pickup Trucks (**EO D-553-11**)

1045840 meets CARB requirements for the following models: 2004-2010 2500/3500 6.6L Diesel Pickup Trucks, 06-07 Express/Savana (**EO-D-553-23**)

## **PRE-INSTALLATION**

A new turbocharger will not solve the following failures:

- Oil contamination
- Restrictive oil drain
- Over speed due to a boost leak
- Exhaust leaks due to faulty bellows, clamps, or seals

Turbo over speed will lead to premature turbo failure. Boost pressure can be used to estimate turbo speed. The table below shows maximum allowable turbo speed for a stock motor at 3500rpm. A turbo intake restriction, clogged filter, high altitude or boost leak will cause increased wheel speed.

Turbo	Estimated Airflow (lb/min)	Max Wheel speed (rpm)	Max boost (psi)	Max Boost with clogged filter (psi)
LLY, LBZ, LMM	85	121,000	40	37
LML	80	121,000	39	36

## **Kit Contents**

**1045830**



Turbo; Screamer 2011-16 LML

**Qty: 1**

**1045840**

Turbo; Screamer 2004.5-2010 LLY, LBZ, LMM

**Qty: 1*****Introduction***

The BD Screamer turbo series is now available for the 2004.5-2016 Duramax. The Screamer turbo is designed to be a drop-in stock-appearing performance turbocharger that increases the total airflow without affecting low-end drivability.

BD's Duramax screamer line-up utilizes a custom mixed flow turbine (MFT) wheel with a large 65mm exducer. In the GT37 VNT, a MFT wheel geometry offers increased efficiency in both initial spool up and high flow operation. At high flow operation, the increased efficiency of the MFT wheel allows the variable nozzle technology to open up and act like a larger turbine housing, which reduces drive pressure and lowers the required exhaust gas temperatures. During turbocharger spool up, the vanes close, creating high velocity "jets" used to spool the turbocharger. The geometry of the MFT more efficiently harnesses these high velocity jets, allowing the use of a larger compressor wheel without compromising on drivability.

***Installation***

The 2004.5-2010 Duramax Screamer turbo fits all LLY, LBZ, and LMM engine codes. The LLY engines will require the vane positions sensor adapter, part number 771864-0001.

Please follow GM's factory replacement instructions for detailed year specific turbocharger replacement procedure.

1. Prior to beginning installation, confirm the vane position sensor is installed on the turbo. Some turbos models are shipped disassembled to prevent shipping damage.

If not installed, first ensure the mating surfaces are dry and clean.

Thread in and torque the sensor to **21 lb ft** in the position shown.



2. Install the oil return pipe using a new gasket.

Torque to **21 Nm (15 lb ft)**

3. Install the turbocharger outlet coolant pipe banjo bolt and washers.

Torque to **26 Nm (19 lb ft)**

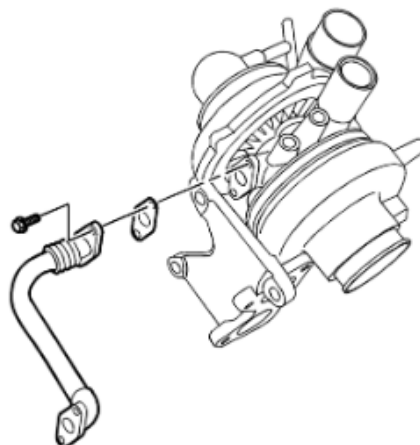

4. Install the oil feed pipe, washer, and bolt.

Do not twist the oil feed pipe.

Torque to **34 Nm (25 lb ft)**

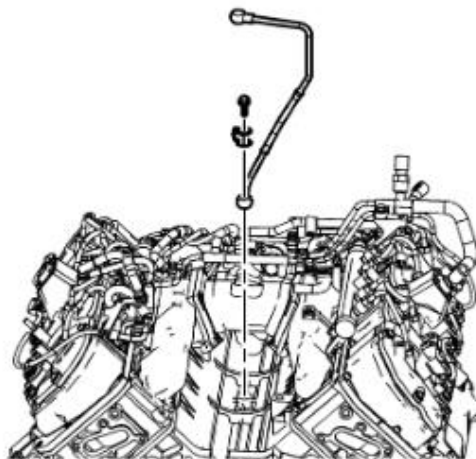

5. Install the turbocharger lower heat shield.

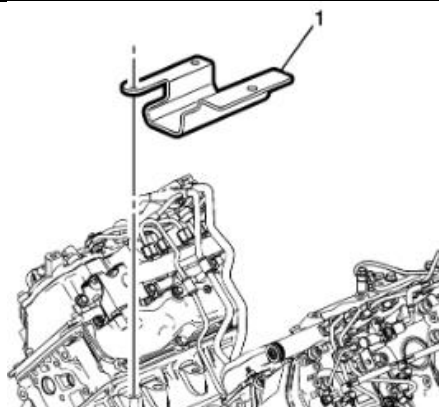

6. Install the turbocharger with the oil return pipe.

Torque the turbocharger mounting bolts to **78 Nm (58 lb ft)**

7. Install the oil return pipe nuts at the top of the flywheel housing. Torque to **25 Nm (18 lb ft)**.

**NOTE:** Due to update on Garrett Turbochargers, the crossover high-pressure fuel line may need adjustment to clear compressor cover. (see photo, right)

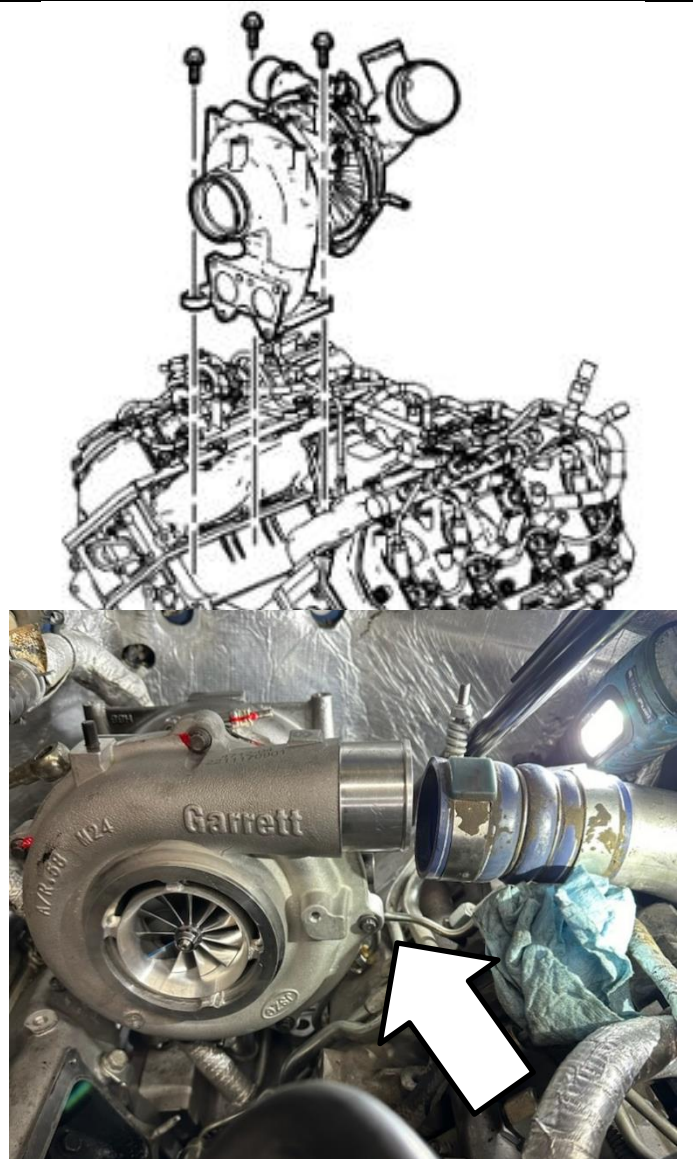

8. Connect the vane position sensor connector.

9. Pre-lube and add **120-150cc** of clean engine oil in the turbocharger oil feed pipe while rotating the impeller.

10. Install the oil feed pipe, washer, and banjo bolt. Torque to **34 Nm (25 lb ft)**

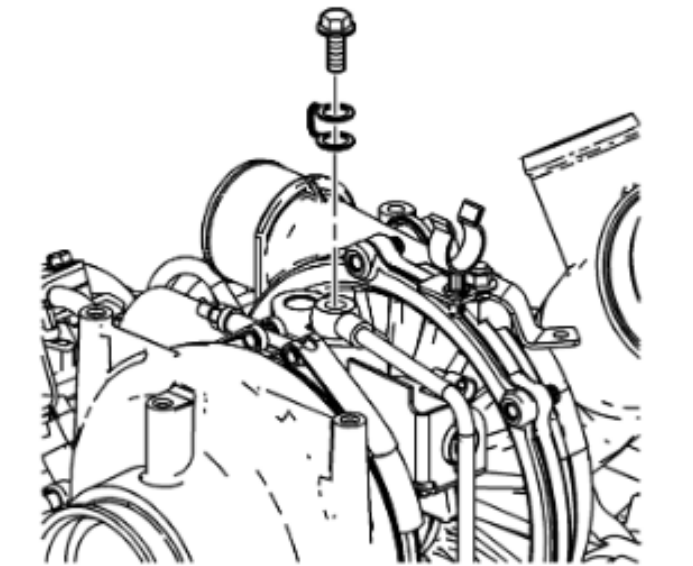

11. Install PCV hose/pipe.

12. Install the cooling outlet hose eye bolt and any remaining coolant hoses.

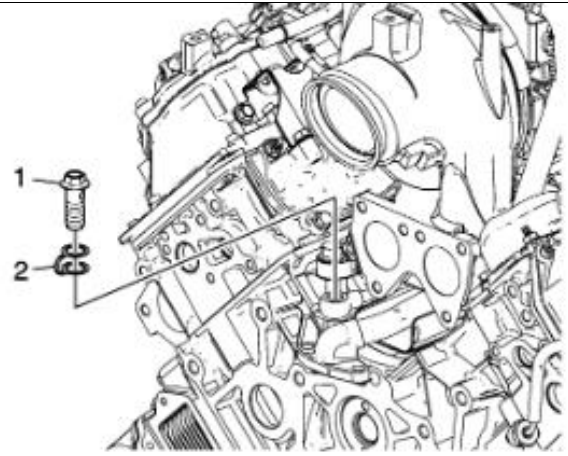

13. Install the turbocharger heat shield and bolts.

Torque to **9 Nm (7 lb ft)**

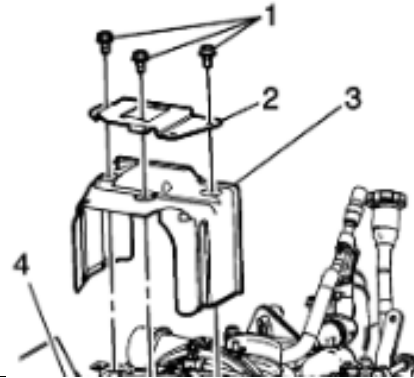

14. Install the exhaust manifold outlet pipes.

Tighten in the sequence shown.

Torque the manifold bolts to **53 Nm (39 lb ft)**

Torque the turbocharger bolts to **25 Nm (18 lb ft)**

Torque the EGR bolts to **25 Nm (18 lb ft)**

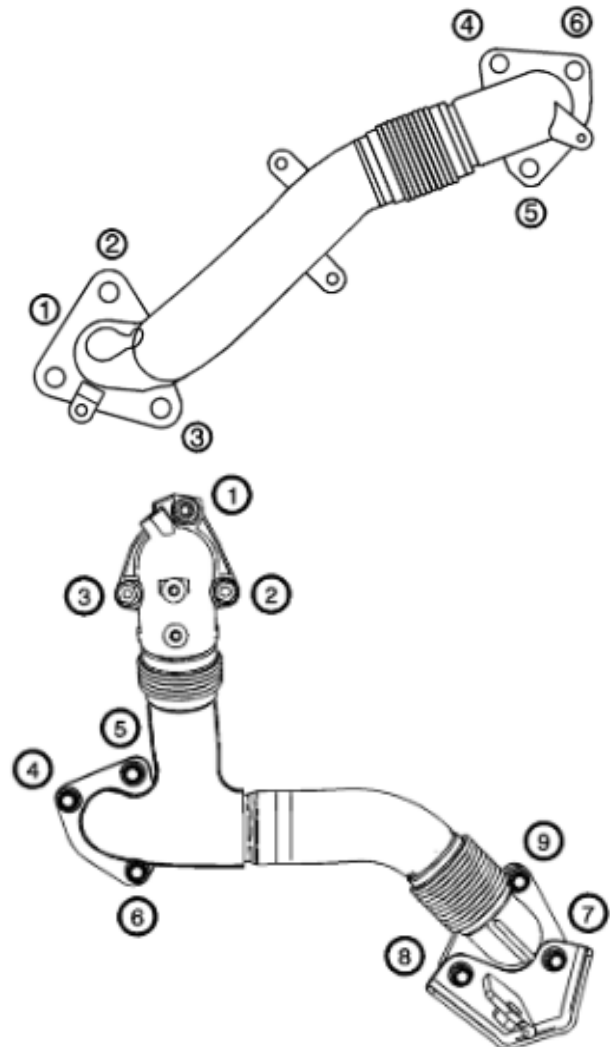

- 15. Reinstall the EGR cooler.
- 16. Reinstall the glow plug module and both brackets.
- 17. Install the EGR cooler pipe bolt.  
Torque to **9 Nm (6.6 lb ft)**

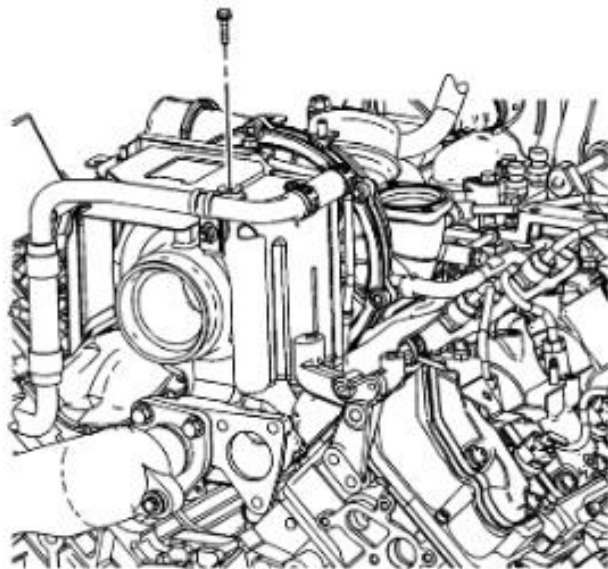

- 18. Install the charge air cooler inlet pipe.
- 19. Install the turbocharger air intake pipe.
- 20. Install the exhaust downpipe.  
Tighten clamp to **40 Nm (30 lb ft)**

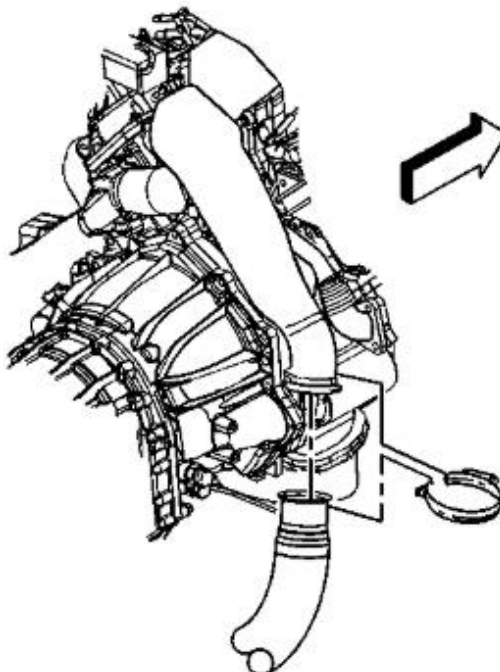

21. **Required For California Customers Only:** Apply the CARB EO decal underneath the hood as indicated.

**IMPORTANT:** Only for applicable models as listed on page 1 of this installation manual.



22. Perform the turbocharger learn procedure.

## ***Turbocharger Learn Procedure***

The engine control module performs the turbocharger learn procedure automatically when the engine coolant temperature is at least 72°C (162°F). After each ignition cycle, and before the enable criteria have been met, the ECM will use the previously learned value. If the ECM does not have a previously learned value, it will default to a stored calibrated value. The ECM will use this value until the enable criteria have been met. It will then perform this procedure to learn the new value. If the ECM attempts to perform the turbocharger learn procedure and fails, DTCs P003A or P2563 may set.

If a TC learn is not performed after a related turbocharger repair, the ECM will use a stored vane position value that may be invalid. The ECM may then cause a diagnostic to fail and set an invalid DTC. Certain enable criteria must be met for the ECM to perform this procedure.

The turbocharger learn procedure is required when the following service procedures have been performed.

- TC vane position control solenoid valve replacement
- TC vane position sensor replacement
- ECM replacement
- TC replacement
- Any service that disrupts the TC components