

*FREE SHIPPING ON ORDERS OVER \$98 (EXCLUSIONS APPLY)



SHOP CATEGORIES

WHY S&B

SHOP BY VEHICLE



0

INSTALL INSTRUCTIONS FOR 75-5129



PRINT

BEFORE YOU START

Please read the entire product guide before proceeding. Ensure all parts are present. If you are missing any of the components, call our customer support at (909) 947-0015. Do not work on your vehicle while the engine is hot. Make sure the engine is turned off and the vehicle is in Park or the Parking Brake is set.

REQUIRED TOOLS

8mm Socket/Ratchet, 10mm Socket/Ratchet, 10mm Wrench, Panel Popper, Adjustable Crescent Wrench, Phillips Screwdriver, Scissors, Heavy Duty Wire, Cutters

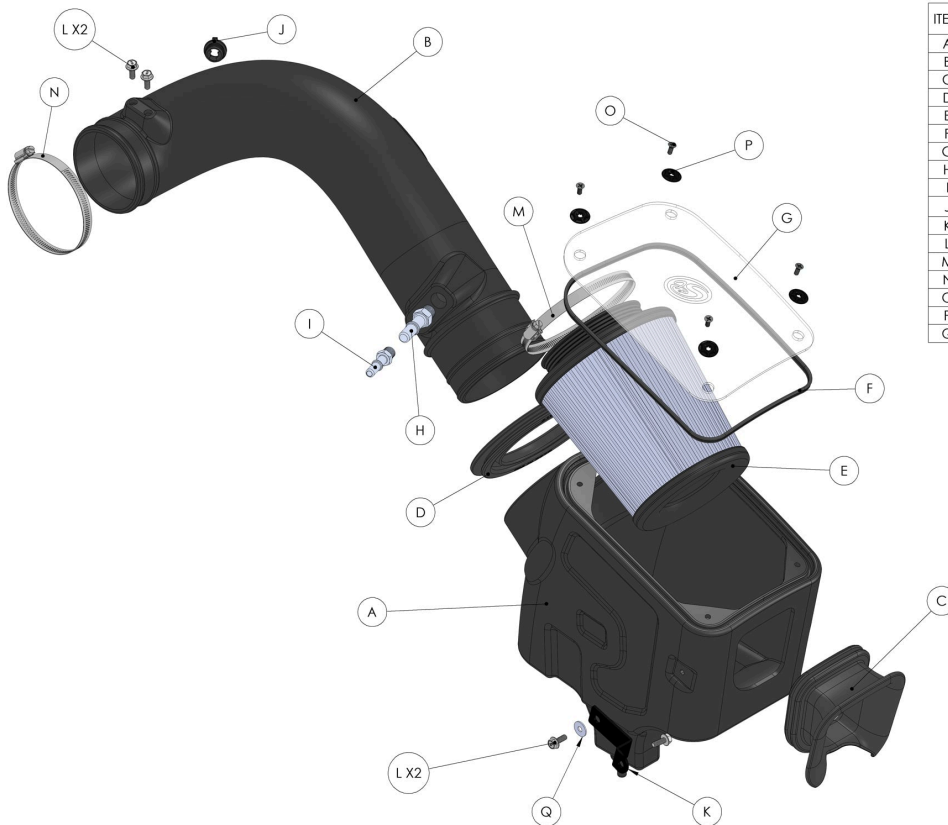

ITEM	PART NUMBER	DESCRIPTION	QTY
A	AL1339B-00	INTAKE BOX	1
B	AL1343-00	INTAKE TUBE	1
C	AI2108C-00	FENDER SEAL	1
D	AI1650C-00	TUBE SEAL	1
E	KF-1057	AIR FILTER	1
F	AI1766-07	LID SEAL, 31"	1
G	AI2120-00	CLEAR LID	1
H	AI2156-00	QUICK CONNECT, 1/2" TO 3/8" NPT	1
I	AI1776-00	QUICK CONNECT, 3/8" TO 1/4" NPT	1
J	AI1948C-00	IAT SENSOR GROMMET	1
K	AI2113-CT	INTAKE BOX SUPPORT BRACKET	1
L	AI2014-00	BOLTS, FLANGE, M6X16MM	4
M	AG1010-00	HOSE CLAMP #80	1
N	AG1018-01	HOSE CLAMP #64	1
O	AI2005-00	LID SCREW, #10-24	4
P	AI2006-00	LID WASHER, #10	4
Q	AI1755-00	M6 WASHER	1



Hi. Need any help?

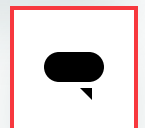

Cookie Preferences

STEP 1

With the ignition switched off and the parking brake set. Disconnect the negative battery cable on the passenger side.

IMPORTANT: Failure to disconnect the battery for a minimum of 2 hours may cause the Check Engine Light to illuminate upon completion of the installation or subsequent operation.

DO NOT SKIP THIS STEP!

Warning!: The Jeep JL's have a smaller secondary battery underneath the main battery and fuse box. This battery will remain connected during the install so keep in mind that the wires are still live when working on your vehicle.

Tools Required: Ratchet,
10mm Socket/Wrench



STEP 2

Remove the two EVAP tubes from the stock airbox by pressing down on the grey plastic retainer clips and pulling the tube fittings away from the stock airbox.



STEP 3

Disconnect the IAT electrical harness from the IAT sensor by pressing down on the locking tab and pulling off the IAT sensor connector.



STEP 4

Disconnect the IAT harness clip from the stock intake tube.

STEP 5

Remove the two bolts securing the stock intake tube to the fan shroud.

Tools Required: Ratchet, 10mm Socket/Wrench

STEP 6A

Loosen the hose clamp securing the stock intake tube to the turbo resonator.

Tools Required: Ratchet, 8mm Socket/Wrench

[Cookie Preferences](#)

STEP 6B

Loosen the hose clamp securing the stock intake tube to the intake air box, then remove the stock intake tube from the vehicle.

Tools Required: Ratchet, 8mm Socket/Wrench

STEP 7

Remove the bolt securing the stock intake box to the fender.

Cookie Preferences
Tools Required: Ratchet,
10mm Socket/Wrench

STEP 8

Lift the stock intake box to unseat the prongs from the grommets then remove the stock intake box from the vehicle.

STEP 9

Check to make sure the two grommets are still in place in the vehicle. If they are missing, they were probably removed with the stock intake box. If the grommets came out of the vehicle with

Cookie Preferences take box, remove the grommets from the stock

intake box and reinstall into the vehicle.

STEP 10

Remove the bolt, closest to the fender, from the battery tray bracket.

Tools Required: Ratchet,
10mm Socket/Wrench

STEP 11

Remove the two bolts securing the wire harness bracket to the turbo resonator chamber.

Tools Required: Ratchet,

et/Wrench

STEP 12

Disconnect the clip securing the wire harness to the turbo resonator.

Tools Required: Panel Popper

STEP 13A

Remove the crimp/ear hose clamp, securing the turbo resonator chamber to the turbo coupler, by cutting through the “ear” of the hose clamp.

[Cookie Preferences](#) [Order: Heavy Duty Wire Cutters](#)

STEP 13B

Remove the turbo resonator from the vehicle.

STEP 14

Install the IAT Sensor Grommet (J) into the Intake Tube (B).

STEP 15A

Notice the position of the IAT sensor on the stock intake tube. Turn the sensor counterclockwise to unlock, then pull out.

STEP 15B

Install the IAT sensor into the Intake Tube (B). Make sure the sensor is installed in the same position as the stock intake tube.

STEP 16A

Install the 90° Fitting, 3/8" Hose to 3/8" NPT (H) into the tube finger tight. Then using a wrench, turn it at least one full rotation, then turn it to so

Cookie Preferences [Setting in the](#)
direction shown.

STEP 16B

Install the plastic Cable Clamp, 3/8" (R) on to the EVAP Fitting (I) as shown. Be sure to install it in the correct orientation.

STEP 16C

Insert the #10-24 X 3/8" Screw (S) through the Cable Clamp, 3/8" (R), and into the tube. Position the EVAP Fitting (I) as shown and tighten the screw. Install the Hose 3/8" ID X 19" LG (Q) on Fitting and EVAP Fitting as shown.

STEP 17

Install the Tube Seal (D) onto the Intake Box (A).

STEP 18

Install the Fender Seal (C) onto the Intake Box (A).

STEP 19

Install the Lid Seal (F) into the groove on top of the Intake Box (A). Cut away any excess lid seal.

Tools Required: Scissors

STEP 20

Install and tighten the Bracket (K) with the M6 Bolt (L) onto the Intake Box (A). Do not overtighten.

Tools Required: Ratchet, 10mm Socket/Wrench

STEP 21

Install the Intake Box (A) into the vehicle, making sure the

Cookie Preferences with the two

grommets, then push down on the intake box to fully seat the prongs.

STEP 22

Position the Fender Seal (C) up against the fender then secure the Bracket (K) to the battery tray bracket with a supplied M6 Bolt (L). Do not overtighten.

Tools Required: Ratchet,
10mm Socket/Wrench

STEP 23

Place the supplied #64 Hose Clamp (N) onto the turbo coupler, do not tighten.

Cookie Preferences

STEP 24A

Install the Intake Tube (B) into the Intake Box (A) at an upward angle.

STEP 24B

Rotate the Intake Tube (B) downward and install into the turbo coupler.

STEP 24C

Once the Intake Tube is installed into the turbo coupler, tighten the #64 Hose Clamp (N). Do not overtighten.

Tools Required: Ratchet, 8mm Socket/Wrench

STEP 25

Install the wire harness bracket onto the Intake Tube (B) with the M6 Bolts (L).

Tools Required: Ratchet, 10mm Socket/Wrench

STEP 26

Connect the IAT electrical harness into the IAT sensor.

STEP 27

Reconnect the two EVAP tubes to the EVAP Fitting (I). There should be an audible click when the tubes are fully inserted.

STEP 28

Install the Air Filter (E) and #80 Hose Clamp (M) onto the Intake Tube (B) then tighten the hose clamp. Do not overtighten.

Tools Required: Ratchet, 8mm

[Cookie Preferences](#) nch

STEP 29

Remove the protective covering from the Clear Lid (G).

STEP 30

Place the Clear Lid (G) onto the Intake Box (A) then secure using the provided Lid Screws and Washer (O & P). Do not overtighten.

Tools Required: Screwdriver

STEP 31

Cookie Preferences

Reconnect the negative terminal on battery. Inspect your installation, make sure the kit is properly positioned and all fasteners are secured. S&B Filters recommends keeping all stock parts in case you would ever need to reinstall the stock intake.

Tools Required: Ratchet,
10mm Socket/Wrench

STEP 32

The installation is now complete.

[Cookie Preferences](#)