



INSTALL INSTRUCTIONS FOR 75-5074

[PRINT](#)

BEFORE YOU START

This intake kit may not fit with the following Aftermarket Parts installed:

Body Lift or Lowering Kit

Custom Hood

Throttle Body Upgrade

- Please read the entire product guide before proceeding.
- Ensure all parts are present.
- If you are missing any of the components, call our customer support at (909) 947-0015.
- Do not work on your vehicle while the engine is hot.
- Make sure the engine is turned off and the vehicle is in Park or the Parking Brake is set.

REQUIRED TOOLS

- 8mm, 10mm, 13mm Wrench & Socket
- Pin Removal Tool or Flat Blade Screwdriver
- 7/16" Wrench and Socket
- 5/16" Nut Driver or Flat Blade Screwdriver
- Phillips Screwdriver
- 1 Set of Torx Wrenches & Allen Wrenches
- 1 Pair of Pliers or similar tool



Hi. Need any help?



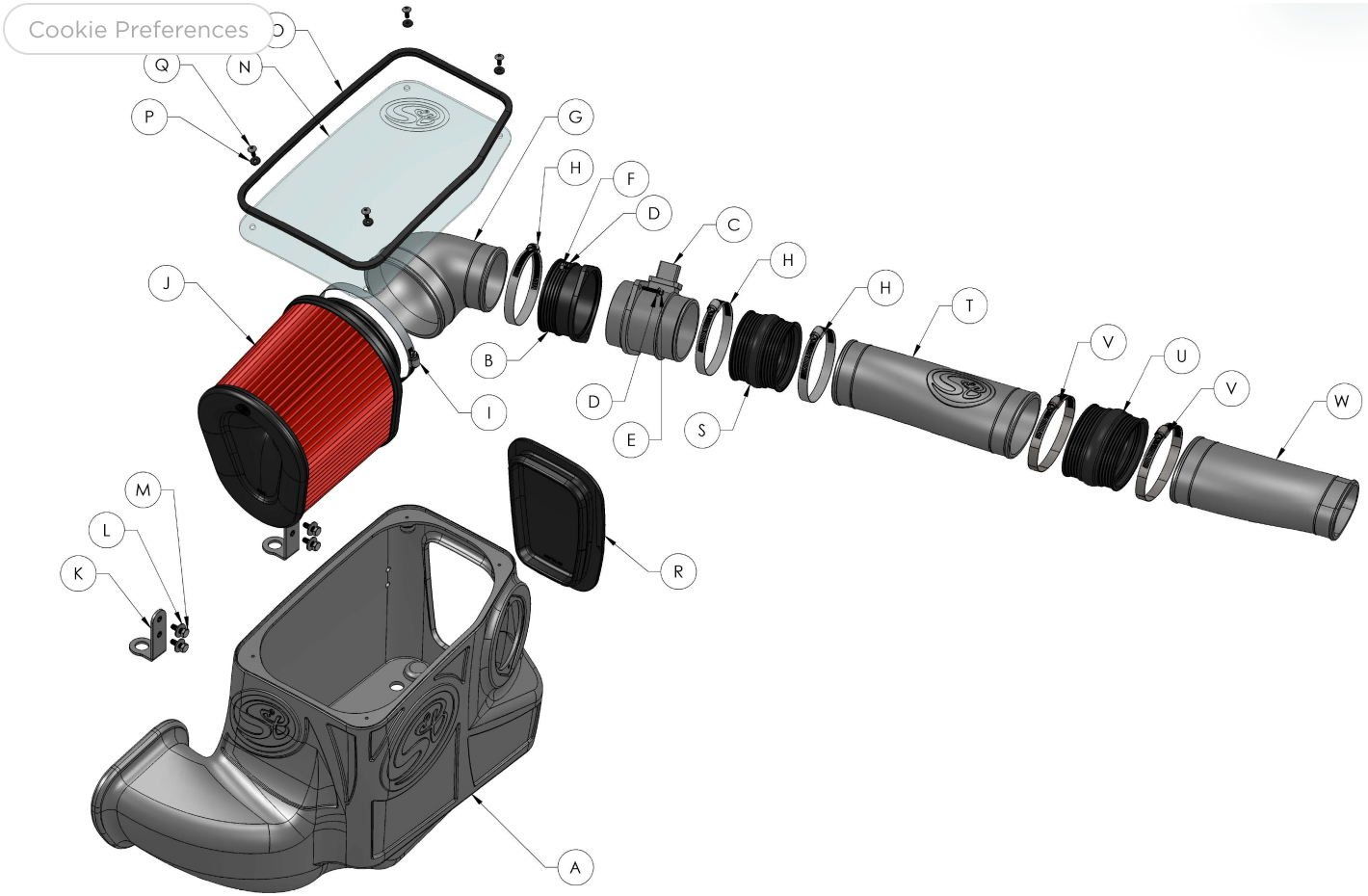

ITEM	QTY.	DESCRIPTION	P/N
A	1	Intake Box	AL1228B-00
B	1	MAF Adapter	AI1672C-00
C	1	Factory MAF	
D	4	3/16" Washer	AI1698-00
E	2	8-32 Screw	AI1697-00
F	2	Locknut 8-32	AI1699-00
G	1	Filter Adapter	AL1228A-00
H	3	Hose Clamp #52	AG1007-00
I	1	Hose Clamp #88	AG1011-00
J	1	S&B Air Filter	KF-1061
K	2	Mounting Bracket, Air Box	AI1677-00
L	4	Washer 1/4"	AI1073-00
M	4	Screw 1/4-20	AI1068-00
N	1	Box Lid	AI1675-00

ITEM	QTY.	DESCRIPTION	P/N
O	1	Lid Seal	AI1636-04
P	4	Washer#10	AI1540-00
Q	4	Screw 10-24	AI1539-00
R	1	Box Plug	AI1673C-00
S	1	Hump Coupler 3" x 2.5"	AI1601C-00
T	1	Long Tube	AL1228L-00
U	1	Hump Coupler 3.5" x 2.75"	AI1321C-00
V	2	Hose Clamp #60	AG1008-00
W	1	Short Tube	AL1228S-00

STEP 1

With the ignition switched off and the parking brake set, disconnect the negative battery cable on the passenger side.

IMPORTANT: Failure to disconnect the battery for a minimum of 2 hours may cause the Check Engine Light to illuminate upon completion of the installation or subsequent operation. **DO NOT SKIP THIS STEP!**

STEP 2

Remove the factory engine cover by pulling up and out.



STEP 3

[Cookie Preferences](#)

nect the MAF sensor harness by pulling out the red latch and pushing down on the release button and pulling out.



STEP 4

Use a 5/16" nut driver to loosen the hose clamp on the MAF.

[Cookie Preferences](#)

STEP 5

Pull the tube off the MAF and pull away.

STEP 6

Use a 5/16" nut driver to loosen the hose clamp on the turbo inlet.

STEP 7

Remove the complete tube assembly from the vehicle.

[Cookie Preferences](#)

STEP 8

Remove the lid by first removing the latches on the side of the factory airbox.

STEP 9

Remove the airbox lid by lifting up and out.

STEP 10

Remove the stock air filter.

Cookie Preferences

STEP 11

Remove the harness that is attached to the side of the stock airbox.

[Cookie Preferences](#)

STEP 12

Remove the stock airbox by pulling up and out.

STEP 13

Remove the two factory grommets on the bottom of the factory airbox.

Cookie Preferences

STEP 13 (IMAGE 2)

STEP 14

Install both grommets on the bottom of the S&B airbox.

STEP 15

Remove the grommets from the factory airbox side tabs.

[Cookie Preferences](#)

STEP 16

Push both grommets into part (K) Mounting Brackets. Put brackets to the side which will be used later in the install.

Note: Placement of the grommet in the bracket is with the large end facing downward.

STEP 17

Remove the factory MAF from the factory lid using a T-30 Torx.

STEP 18

[Cookie Preferences](#)

Remove the rubber O-ring from the factory MAF.

STEP 19

Install the MAF Adapter (B) into the S&B airbox (A). Make sure it is aligned properly.

STEP 20

Install the factory MAF into the MAF Adapter in the S&B airbox. This is designed to be a tight fit and may take some effort, carefully align the MAF Sensor to the Adapter.

[Cookie Preferences](#)

STEP 21

Make sure the MAF is aligned properly and that the flanges meet together.

STEP 22

Use the provided hardware (D, E, F) to mount the factory MAF onto the S&B airbox.

[Cookie Preferences](#)

STEP 23

Assemble the S&B tube by connecting both the S&B Short Tube (W) and Long Tube (T) using the Hump Coupler (U) and the provided Hose Clamps (V). Also, install Coupler (S) on the end with Hose Clamps (H).

[Cookie Preferences](#)

STEP 24

Install the Filter Adapter (G) onto the S&B Air Filter (J). Use a screwdriver to lineup the S&B logo on the filter straight with the (-) on the part number of the Adapter.

STEP 25

Once aligned tighten down the down clamp.

STEP 26

Install the Hose Clamp (H) onto the MAF Adapter (B).

STEP 27

Install both Mounting Brackets (K) with grommets inside the vehicle on the plastic post.

STEP 28

Install the S&B airbox, make sure the bottom grommets align with the factory plastic post underneath.

[Cookie Preferences](#)

STEP 29

Use the provided hardware ([L](#) & [M](#)) to attach the S&B airbox to the brackets.

[Cookie Preferences](#)

STEP 30

Reconnect the factory harness to the MAF.

STEP 31

Install the S&B tube assembly and connect to the factory turbo inlet and tighten the hose clamp.

STEP 32

Slide the coupler towards the S&B airbox over the MAF. Tighten down the hose clamp and make sure the tube is aligned properly.

STEP 33

Install the provided Lid Seal (O) onto the S&B Lid (N).

STEP 34

Install the S&B Filter with Adapter and tighten down Hose Clamp (H) on the MAF Adapter.

Note: Make sure the Filter Adapter is fully inserted into the MAF Adapter, also make sure the top of the filter is

Cookie Preferences Under the top of the
airbox.

STEP 35

Install the Lid (N) onto the S&B airbox using the provided hardware (P & Q) and the install is complete. Please make sure all hose clamps and hardware are tightened.

STEP 36

Note: The optional Box Plug (R) may be removed to provided maximum airflow

[Cookie Preferences](#)

ambient engine heat is
not a factor.