



# TITANIUM SIGNATURE SERIES INSTALLATION MANUAL

## ALL 1/2" FUEL PORTS



**Powerstroke 6.7L**

**\*Bypassing the Factory Lift Pump\*  
Standard Pickup Truck**

**2023-2024**

### APPLICATION:

- TSP-F20-180F-140G  
(140GPH @ 65PSI)
- TSP-F20-250F-220G  
(220GPH @ 65PSI)
- TSP-F20-290F-240G  
(240GPH @ 65PSI)

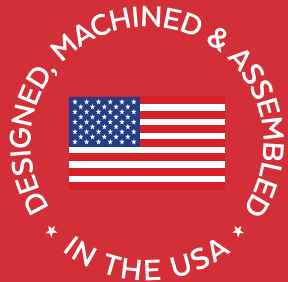

**Note: Cab and Chassis  
may require modifications**



[www.fassride.com](http://www.fassride.com)

(866) 769.3747

## **Thank you for choosing FASS, from Diesel Performance Products, Inc.**

FASS specializes in building extremely high-quality fuel products. We have earned an unsurpassed reputation for excellence in our industry by using only the highest-quality American-made components. In order to support our American workers and our American economy, more than 98+ percent of our products are manufactured completely in the United States.

Of course, that dedication to excellence comes at a price, but it is important to remember that price does not dictate quality-quality dictates price! We will never compromise by using cheaper, foreign-made components, like so many of our competitors do.

Customer satisfaction is our top priority and we strive always to provide outstanding customer service. Our Research and Development department, in conjunction with our Dealer Support Department, continually searches for ways to improve quality, expand our product line, and provide superb support. Our exclusive ViP Network ensures that customers receive the proper products and support at the local level. The extended lifetime warranty is only available on products purchased from the network. There is no warranty on products not purchased outside the network.

## **IMPORTANT:**

*In order to qualify for the lifetime extended warranty, your product registration form and proof of purchase from an authorized dealer must be submitted to FASS Fuel Systems within 30 days of purchase. Failure to comply will void the warranty. We have the right to deny any warranty believed to be false, altered or purchased through an unauthorized or terminated dealer. A current list of authorized dealers can be found on our website, [FASSRide.com](http://FASSRide.com).*

The complete conditions of the Limitation of Warranty can be found in the back of this manual, and [FASSRide.com](http://FASSRide.com).

**For more information,  
contact Technical Support:  
Diesel Performance Products, Inc.  
16234 State Hwy O.  
Marthasville, MO 63357  
636-433-5410**



**WARNING!**

**This product has NO WARRANTY unless:**

**1. It has been purchased from an **Authorized** or **ViP FASS Dealer**. If in doubt, check [www.FASSRide.com](http://www.FASSRide.com).**

**2. It is registered within thirty (30) days of purchase.**

**Other conditions may apply. Please see full warranty information.**

***NOTE:* Warranty is **void** if product was purchased below FASS website advertised pricing.**

**ATTENTION!**

**Before you begin installation**

**Register for your Warranty ONLINE at**

**<https://www.fassride.com/register-a-warranty/>**

**No online access, call our TECH Support at**

**1-866-769-3747**

# FOLLOW THESE STEPS TO ENSURE A SIMPLE, CORRECT INSTALLATION OF YOUR NEW TITANIUM FUEL SYSTEM

## ATTENTION:

**Be sure to identify the proper FASS System and fuel line configuration. For help, our product finder can be found at [www.FASSride.com](http://www.FASSride.com). Follow the instructions to see fuel line detail.**

- 1** Pay close attention to ALL WARNINGS
- 2** Read all instructions before starting installation of this product.
- 3** Inventory the package components. Notify the place of purchase immediately of any parts missing or damaged.
- 4** The installation recommendations contained within are guidelines. Use good judgment and take into consideration your vehicle's accessories.
- 5** For best results in accuracy and efficiency (due to training, communication, and our relationship with our dealer network), we recommend a VIP FASS dealer for the installation. They are prepared to install the FASS fuel pumps with the most efficiency. If a situation or problem arises during the installation, the dealer is prepared to handle it. Diesel Performance Products, Inc. is not responsible for any installation mistakes.
- 6** If you have any questions or concerns that cannot be addressed with your dealer, email or call FASS.

---

**If any installation procedure is uncertain, contact FASS technical support.  
Call customer service at 636-433-5410,  
or send us an e-mail: [techsupport@FASSride.com](mailto:techsupport@FASSride.com)  
with the following information:**

---

Your name, address and daytime phone number  
Model (TSP-F20-180F-140G), (TSP-F20-250F-220G),  
OR (TSP-F20-290F-240G)  
Serial number  
Last 6 digits of vehicles' VIN

Date of purchase  
Nature of Your Concern  
Serial number .....



# INSTALLATION MANUAL

**TSP-F20-180F-140G**

**TSP-F20-250F-220G**

**TSP-F20-290F-240G**

(Installation Videos are available at [www.fassride.com](http://www.fassride.com))

## RECOMMENDED APPLICATION

**TSP-F20-180F-140G:** Powerstroke (6.7L) 2023-2024 with stock - 700 horsepower

**TSP-F20-250F-220G:** Powerstroke (6.7L) 2023-2024 with 700 - 900 horsepower

**TSP-F20-290F-240G:** Powerstroke (6.7L) 2023-2024 with 900 - 1,200 horsepower

1. **Read all instructions before starting installation of this product!**
2. **Installing the improper FASS Pump can cause severe engine damage.**
3. **Secure vehicle from ROLLING!**
4. **Cab and Chassis may require modifications**
5. **Consult vehicle's manufacturers' instructions concerning the electrical system before attempting any electrical connections.**
6. **Flush and clean all brass fittings and fuel line from debris.**
7. **Keep debris from entering the internals of the system during installation. Getting debris in the water separator nipple can lock up the motor. If the motor does lock up from debris call FASS for technical assistance.**

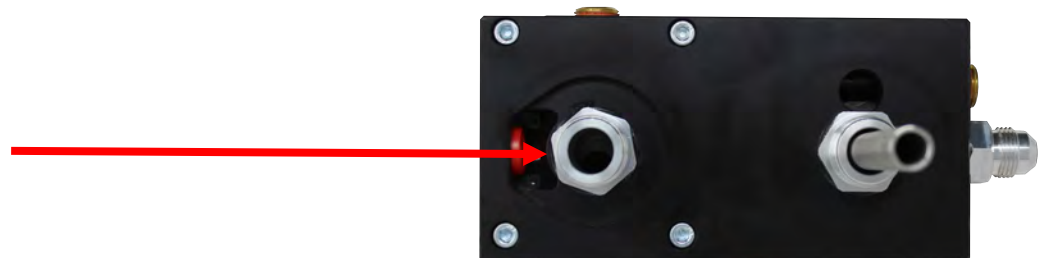

9. **Wear safety glasses when operating power tools such as drills and grinders or when using a punch or chisel.**
10. **Properly secure lines to prevent chaffing.**



**WARNING!**

**Always be sure to fill the fuel tank to full after a new FASS installation. Failure to do so can result in excessive sound output, or priming issues!**

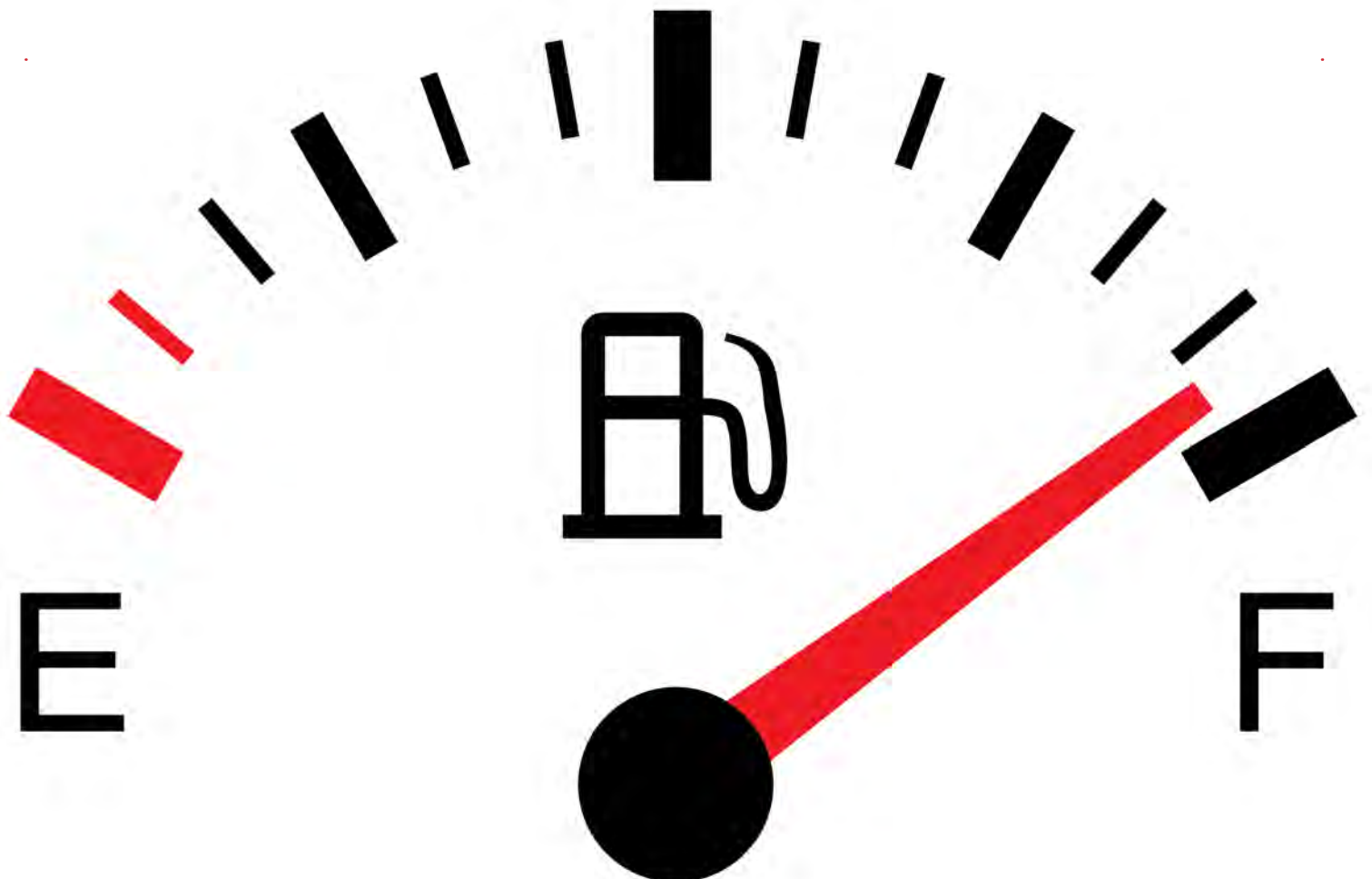

## **TITANIUM SIGNATURE SERIES PLUS 140 GPH, 220 GPH OR 240 GPH**

**65 psi (Approximately)**

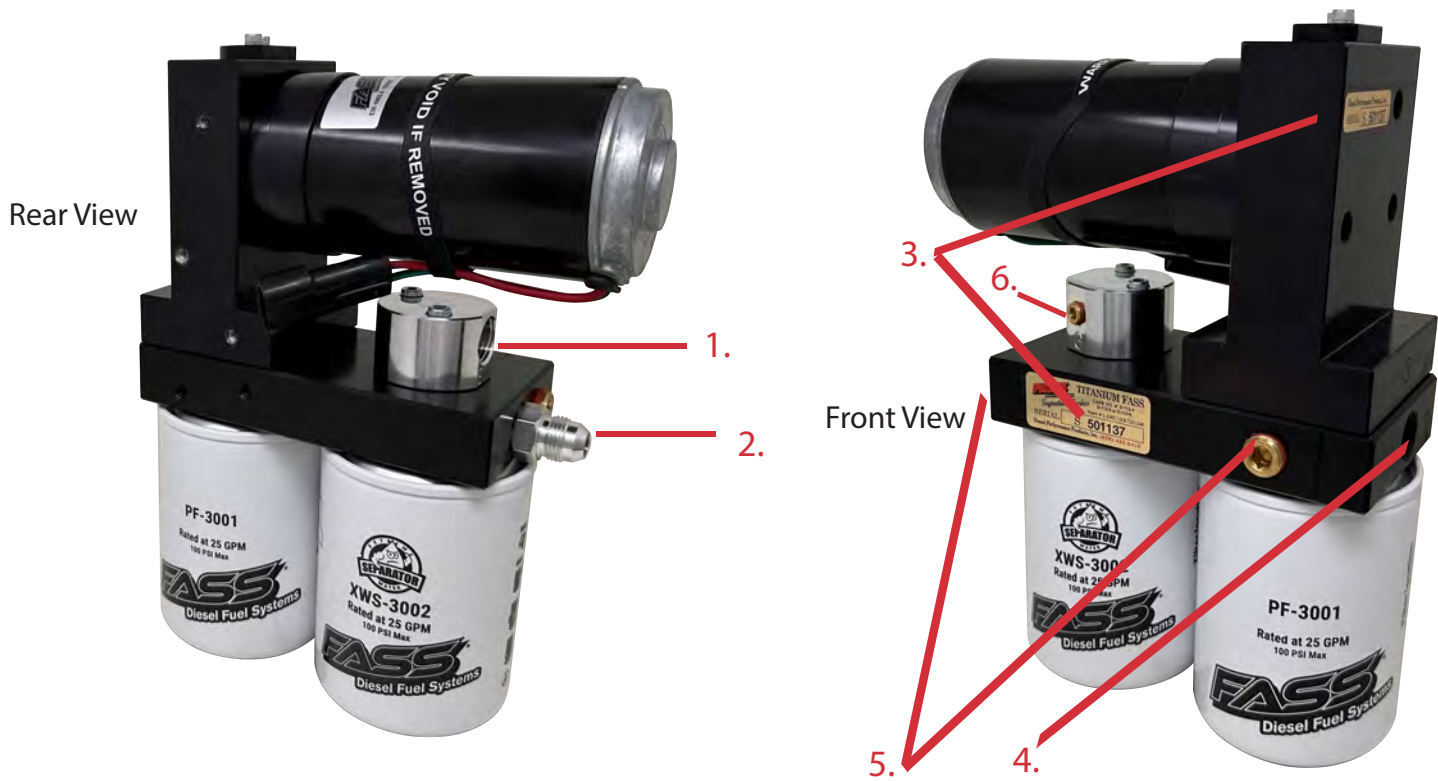

### **PUMP GUIDE:**

- 1. "E" To Engine**
- 2. "R" Return to Tank**
- 3. Serial Number**
- 4. "T" Fuel Inlet**
- 5. Electric Heater Ports**
- 6. "G" Gauge Port**

### **INSTALLATION GUIDE:**

- Step 1. Install Electrical Harness**
- Step 2. Prep the FASS**
- Step 3. Mount the FASS**
- Step 4. Fuel Line Supply**
- Step 5. Review Installation**



www.fassride.com  
(866) 769.3747

**TITANIUM**  
**SIGNATURE SERIES PLUS**  
**140 GPH, 220 GPH OR 240 GPH**  
**65 psi (Approximately)**

**Note: Going over 100 PSI WILL void warranty.**

**NOTE: WARRANTY MAY BE VOID**  
**IF SILICONE BAND IS REMOVED**  
**FROM MOTOR!!**





# CONTENTS

**NOTE:** Owner's Manual available for download on our website,  
[www.FASSride.com](http://www.FASSride.com)



**PBR-2004**



**PBR-2002**

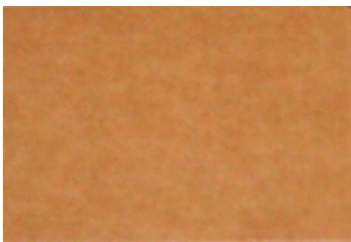

**MP-TSP-9099**



**LRB-1001**



**FL-1002-BK x17'**



**FL-1058-BK x5'**



**WH-1006-3**



**WH-1009-3**



**FL-1009 3/8"**



**FL-1011x5'**



**FL-1006 5/16"**



**FL-1012**

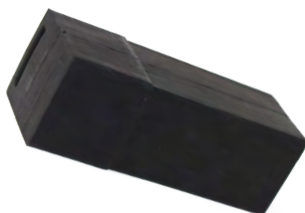

**RELAY COVER**



**30 AMP FUSE**



**FL-1007**

# MOUNTING PACKAGE CONTENTS



**BHF-1010**



**OR-119**



**BHN-1005**



**TWO (2)  
PL-2058-BK**



**TWO (2)  
PL-2003-BK**



**10-305**



**TWO (2)  
QC-4600**



**HBRB-375-1875**



**STF-1001**



**A624A58-55-04**



**A624C56-55-05**



**A614C56-55-05**



**A614A50G06-02**



**PLB-500-2X-1E-NPT**



**PL-500-125NPT**



**FFQC-500BFPC**



**PL-1013**



**AN-8-ORB-10-BK**



**AN90-10-ORB-10-BK**



**THREE (3)  
WA-1001D**



**TWO (2)  
72478**

# MOUNTING PACKAGE CONTENTS



THREE (3) HEX BOLT  
1/4" -20x13/4"



FOUR (4) HEX BOLT  
3/8" -16x11/2"



TWO (2)  
RING TERMINAL

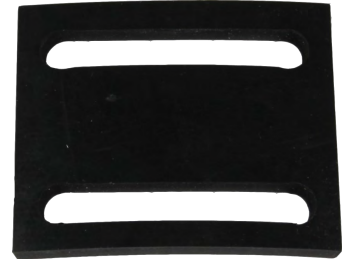

RS-2002

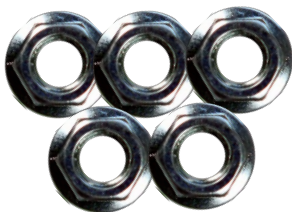

FIVE (5)  
LOCKING NUT 3/8"



FIVE (5)  
3/8" WASHERS

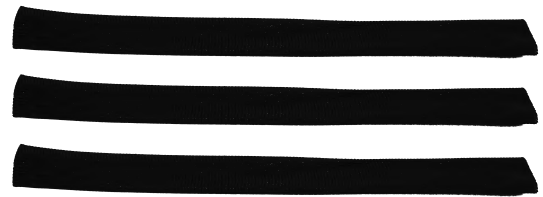

THREE (3)  
1,200°F HEAT SHIELD



TWO (2)  
SELF TAPPING SCREW



SEVEN (7)  
HC-1001

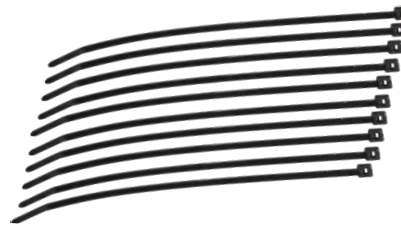

CABLE TIES



31965



VS219P-2



VIB-12230



HC-4001



DIELECTRIC GREASE



TWO (2)  
OR-017



OR-030

*NOTE: THESE SPARE BASE O-RINGS ARE INCLUDED WITH THE KIT IN THE EVENT OF A PINCHED O-RING DURING ASSEMBLY*



LOCKING NUT 5/16"



5/16" WASHERS



HEX BOLT  
3/8" -16x1"



HEX BOLT  
5/16" -18x1"

## **STEP 1:** **INSTALLING ELECTRICAL HARNESS**

- A.** Using the supplied dielectric grease, apply a small amount to the relay pig tail and the fuse holder.



## **STEP 1:** **INSTALLING ELECTRICAL HARNESS**

**B.** Once applied, install the supplied relay into the relay pig tail and the 30 amp fuse into the fuse holder.



## **STEP 1:** **INSTALLING ELECTRICAL HARNESS**

**C.** With the relay and 30 amp fuse installed, install the relay cover and fuse holder cover.



**STEP 1:**

**INSTALLING ELECTRICAL HARNESS**

**D.** Crimp the supplied ring terminals to the red and green wires of the WH-1006-3. Attach the red wire to the positive terminal of the battery and the green wire to the negative terminal of the battery.

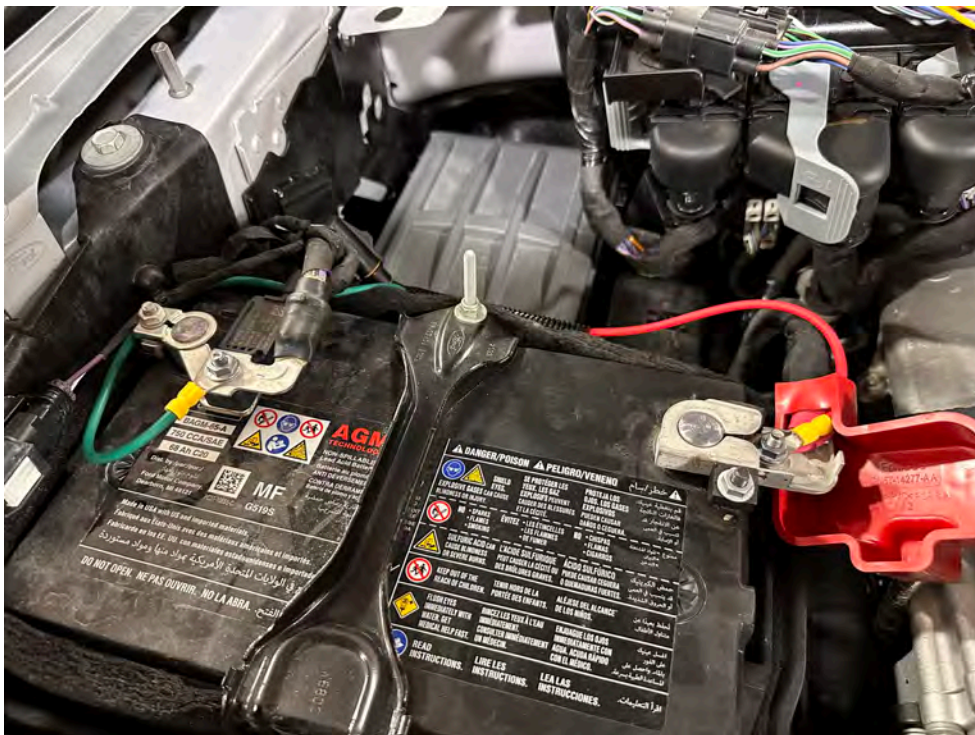
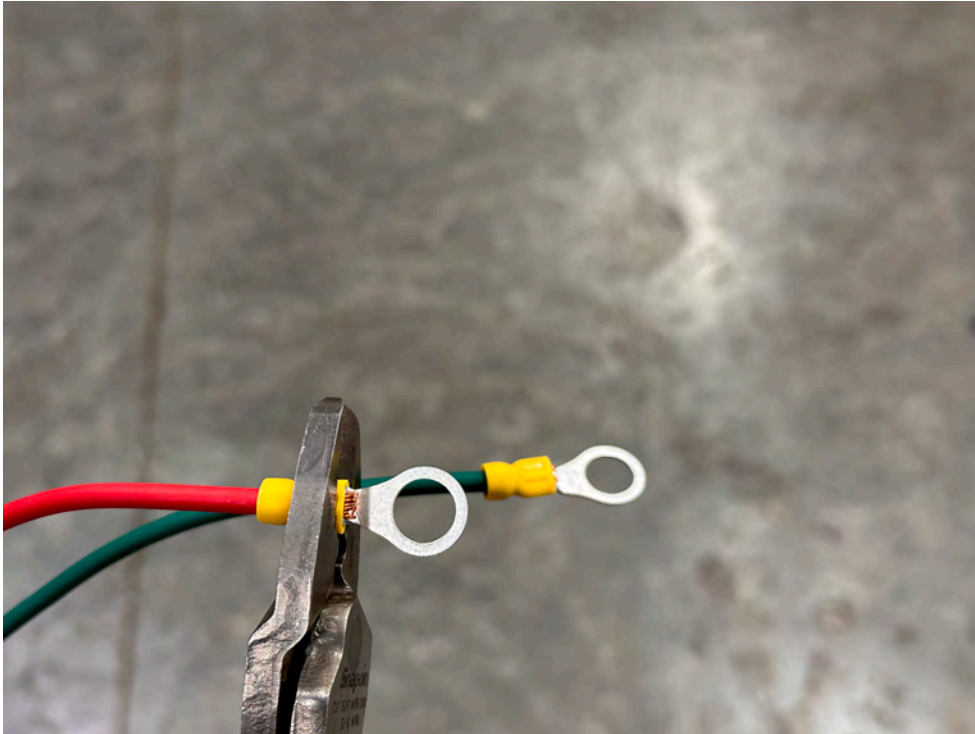

## **STEP 1:** **INSTALLING ELECTRICAL HARNESS**

**E.** Secure the relay and fuse holder in an upright position, as shown , to prevent moisture from entering.

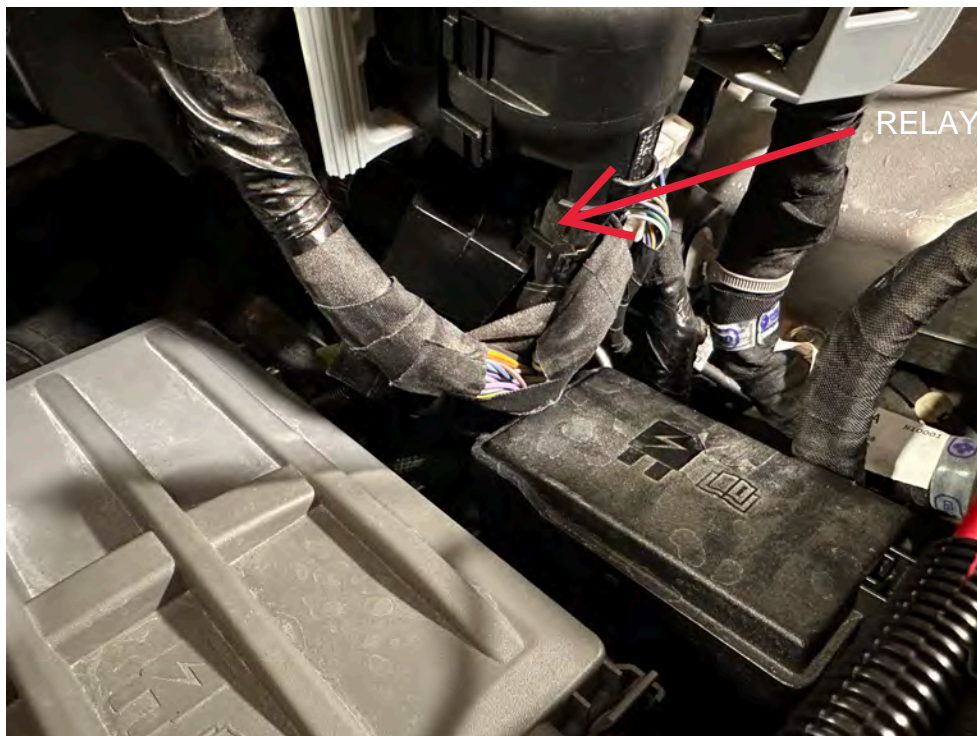
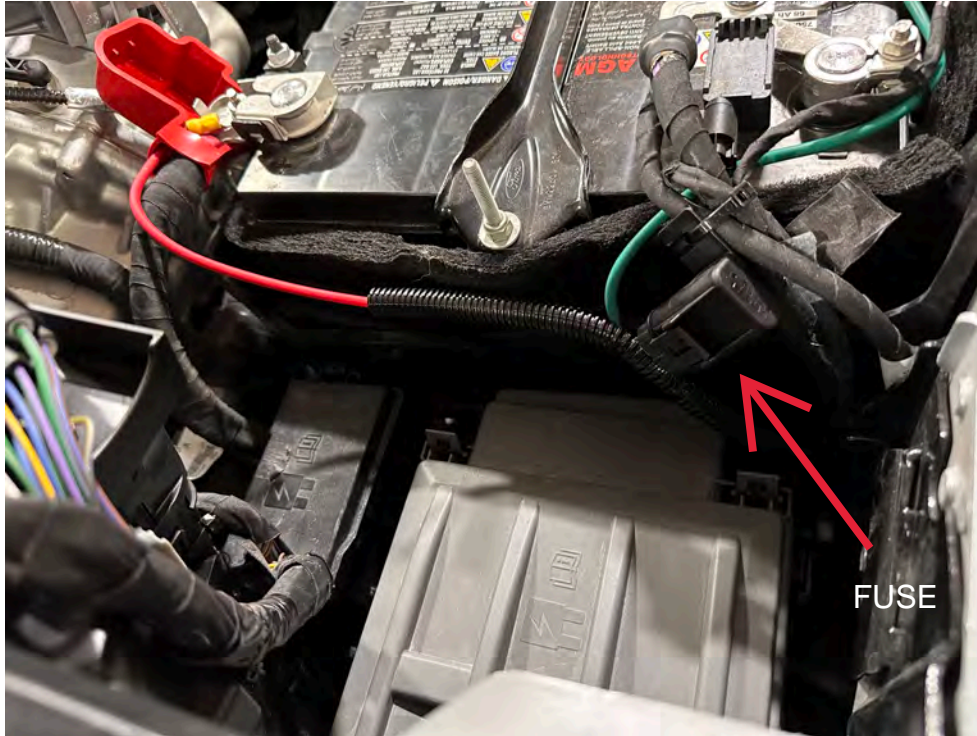



## **STEP 1:** **INSTALLING ELECTRICAL HARNESS**

F. Route WH-1006-3 along the frame rail securing WH-1006-3 with the supplied cable ties, leaving the single red wire located as pictured and the remaining portion to the mounting location of the FASS.



# STEP 1: INSTALLING ELECTRICAL HARNESS

**NOTE: FUEL PUMP CONTROL MODULE LOCATION**

**PUMP MAY RUN FOR A FEW SECONDS AFTER SHUTTING  
VEHICLE OFF.**

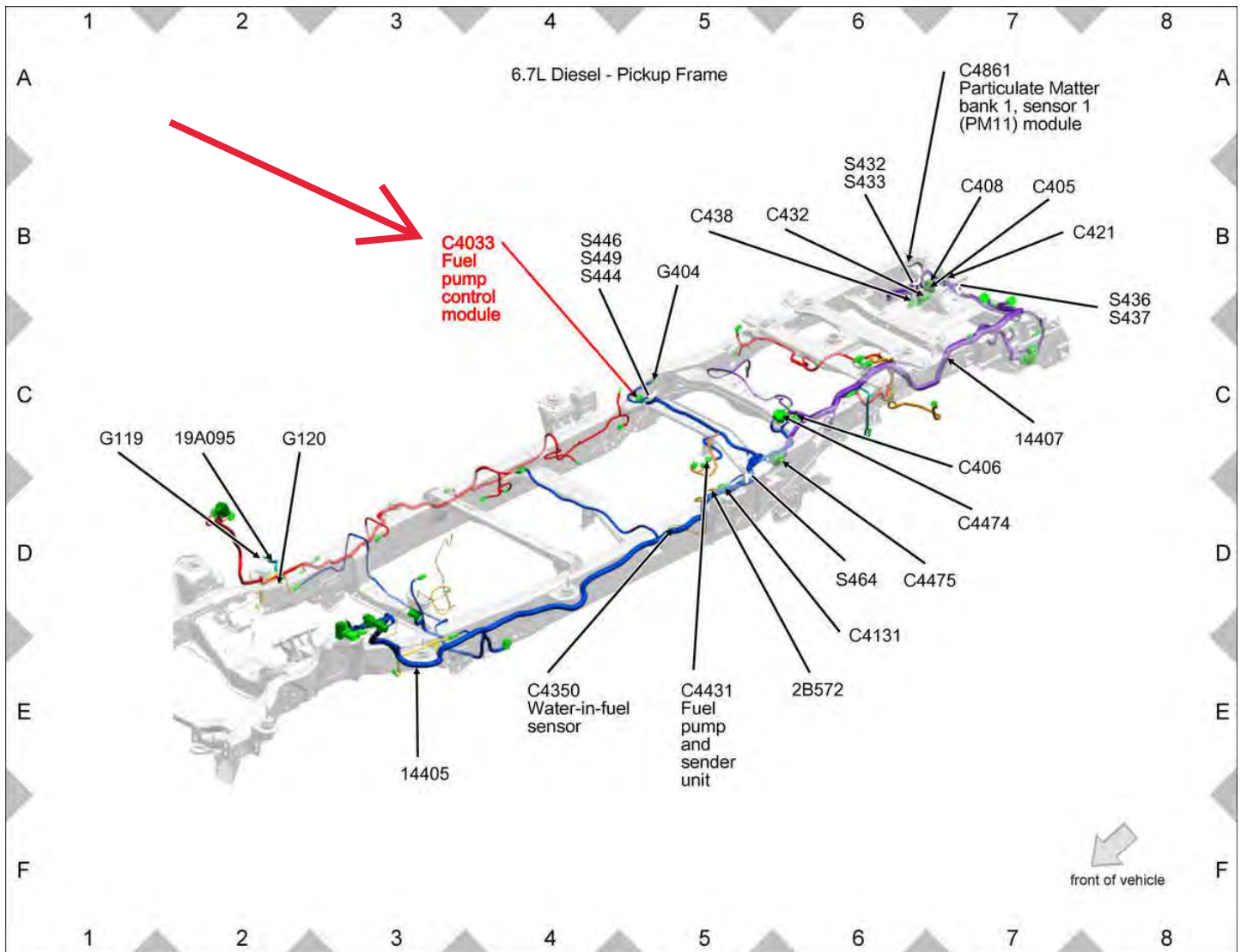

**STEP 1:**

**INSTALLING ELECTRICAL HARNESS**

**G.** Unplug the OEM fuel pump control module connector. Connect the female connector of WH-1009-3 into the OEM fuel pump control module and the male connector of WH-1009-3 into the OEM female connector.

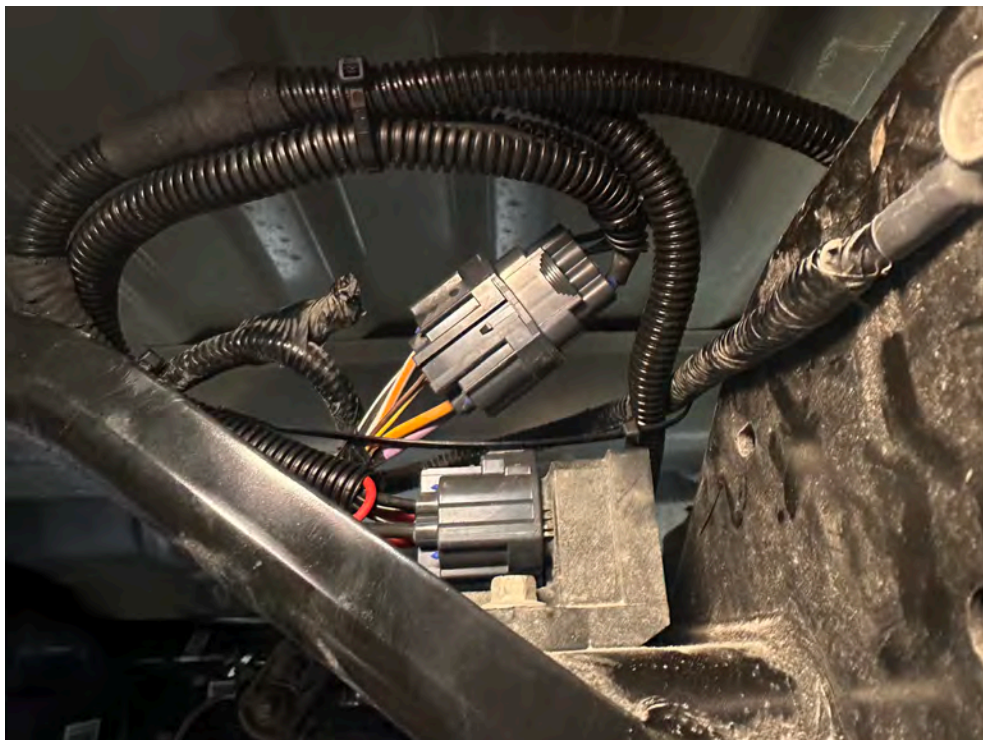

## **STEP 1:** **INSTALLING ELECTRICAL HARNESS**

**H.** Secure LRB-1001 to the Passenger Side frame rail with the supplied self-tapping screws. Secure the resistor from WH-1009-3 to LRB-1001 with the supplied #4 screws.



## **STEP 1:** **INSTALLING ELECTRICAL HARNESS**

- I. Route the single red wire from WH-1009-3 to the location of the single red wire of WH-1006-3. Using a crimping tool, crimp the single red wire from WH-1006-3 and WH-1009-3 into the supplied heat shrink butt connector and secure using the supplied cable ties.

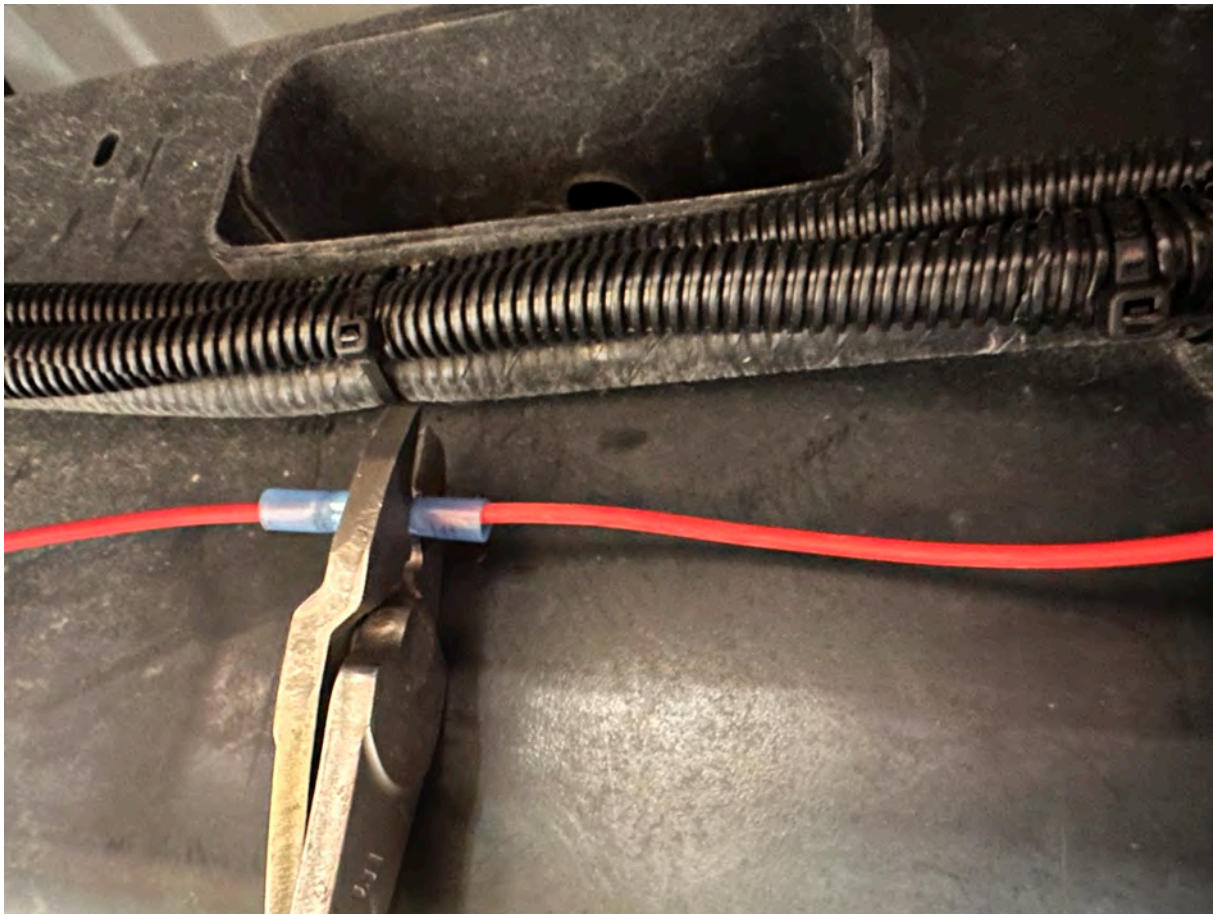

## **STEP 1:**

# **INSTALLING ELECTRICAL HARNESS**

**A.** Place the 3/8" and 5/16" bolts through the supplied washers and the factory drilled holes on the rear passenger body mount. Place PBR-2004 onto the factory body mount using the supplied locking nuts and tighten accordingly.



**NOTE:**

**ATTENTION:** While installing fittings into Titanium pump  
**DO NOT** Apply side pressure to draw tube of pump

**PROPER**



**IMPROPER**

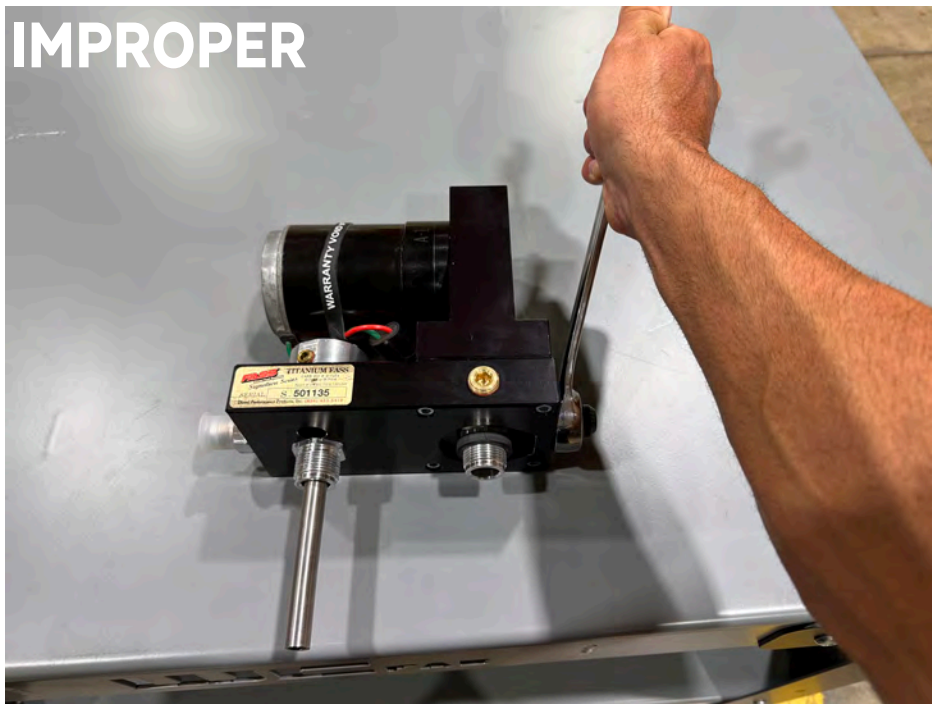

## **STEP 2:** **MOUNT FUEL SYSTEM**

**NOTE: Before installing fittings make sure to inspect for burs or flare imperfections. When cutting fuel line make sure to blow out line to keep debris from moving forward.**

**B.** Install AN-8-ORB-10-BK into the E port of the FASS and AN90-10-ORB-10-BK into the T port of the FASS. Tighten both fittings accordingly.





## **STEP 2:** **MOUNT FUEL SYSTEM**

C. Place the three supplied aluminum spacers onto the FASS as pictured. Place the three 1/4" bolts through PBR-2002 and place the bracket onto the FASS and tighten accordingly.



## **STEP 2:** **MOUNT FUEL SYSTEM**

**D.** Place the four 3/8" bolts through the supplied washers an PBR-2002 with the supplied rubber spacer RS-2002. Place the bracket onto PBR-2004 using the four supplied locking nuts and tighten accordingly.

**NOTE: TORQUE BOLTS NOT FLANGE NUTS**

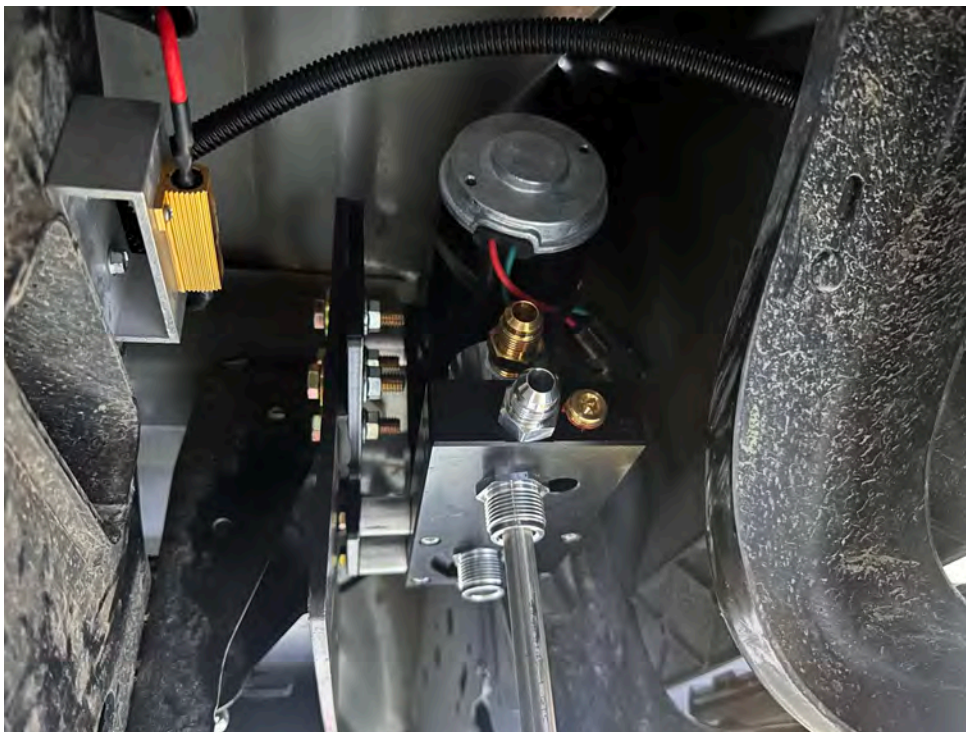
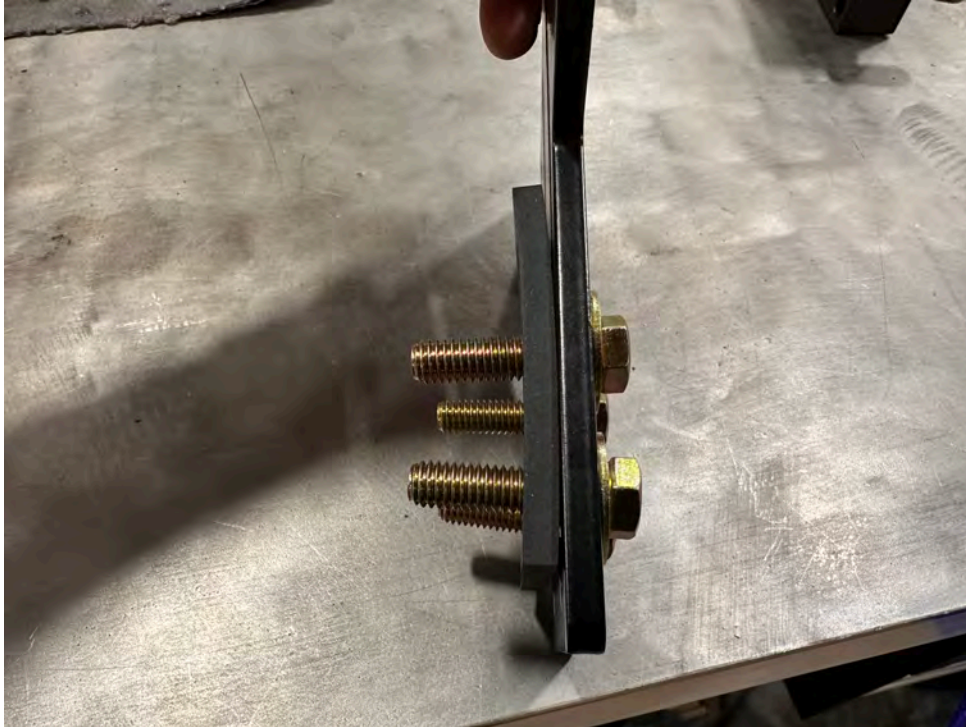

## **STEP 2:** **MOUNT FUEL SYSTEM**

**NOTE: If fuel pressure gauge is pulsating after FASS installation, use snubber valve (Cat Part # 7S-3795)**

**E.** Apply grease to the gasket located on the filters. Attach to the system and hand tighten.



**Extreme Water Separator - Install XWS-3002 on side of pump with draw tube in the middle of the filter nipple.**



**Particulate Filter - Install PF-3001 on filter nipple without the draw tube. Make sure to insert O-Ring provided on nipple.**



**Note: O-Ring must be put back on the suction side of pump. Failure to do so can result in priming issues, cavitation or pressure losses.**

**The images below show the proper steps for disconnecting and connecting the quick-connect style fuel lines.**

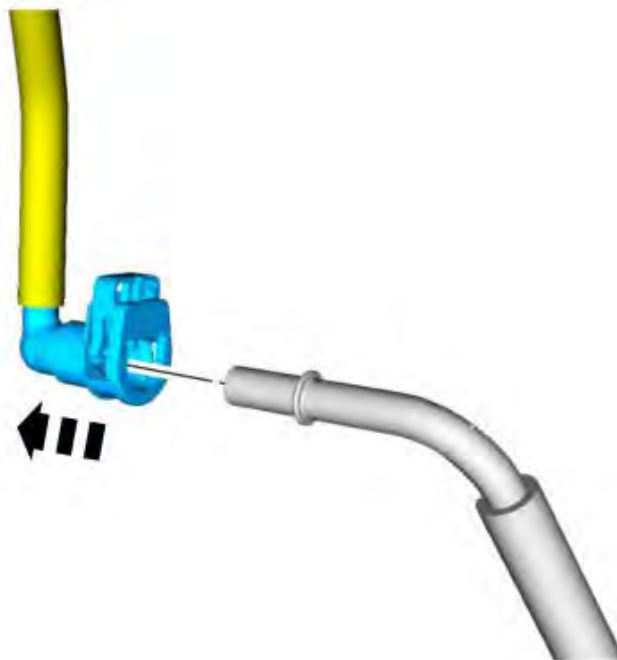
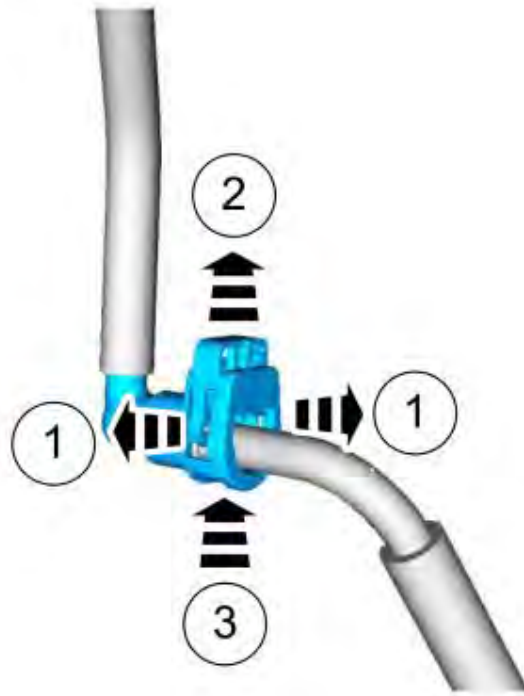

**The images below show the proper steps for disconnecting and connecting the quick-connect style fuel lines.**

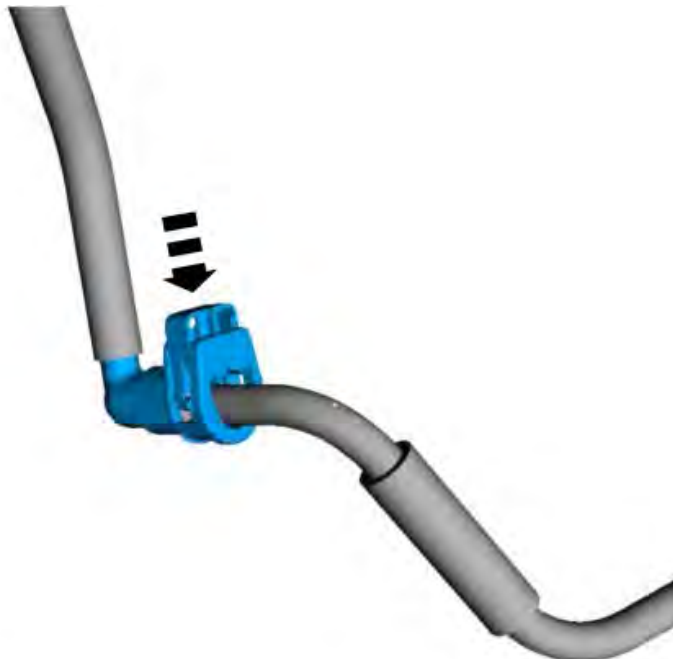
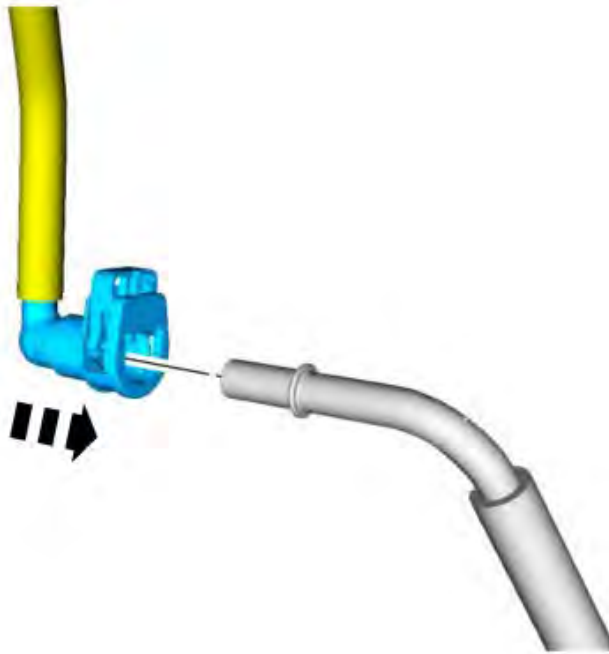

**The images below show the proper steps for disconnecting and connecting the quick-connect style fuel lines.**

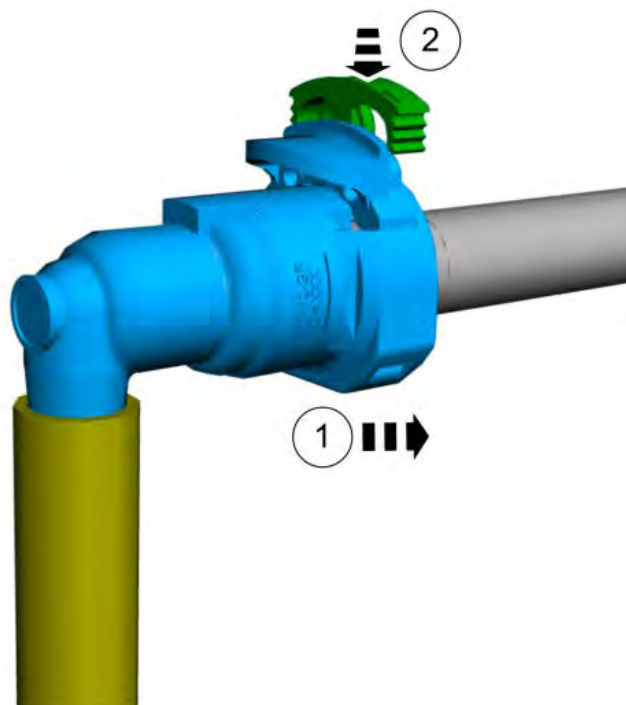
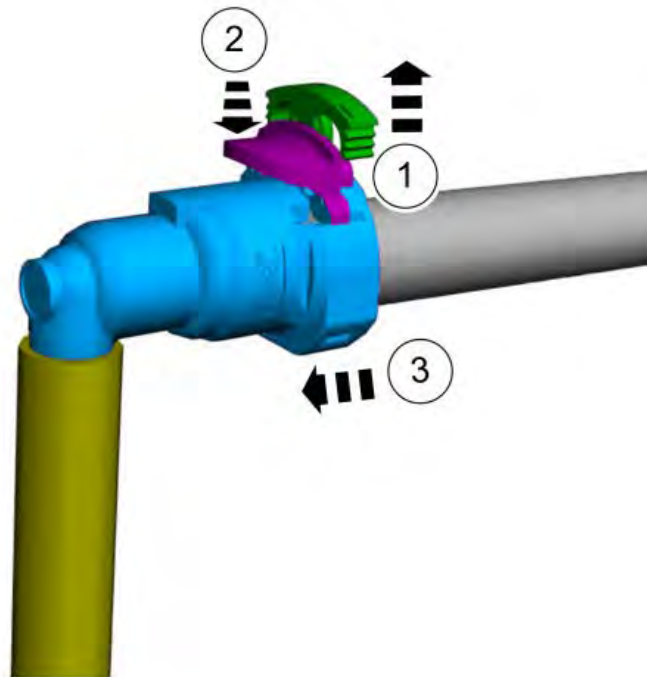

**STEP 3:**  
**PREPARE SUCTION & RETURN LINES**

- A. Place a drain under the fuel conditioning module and drain accordingly.

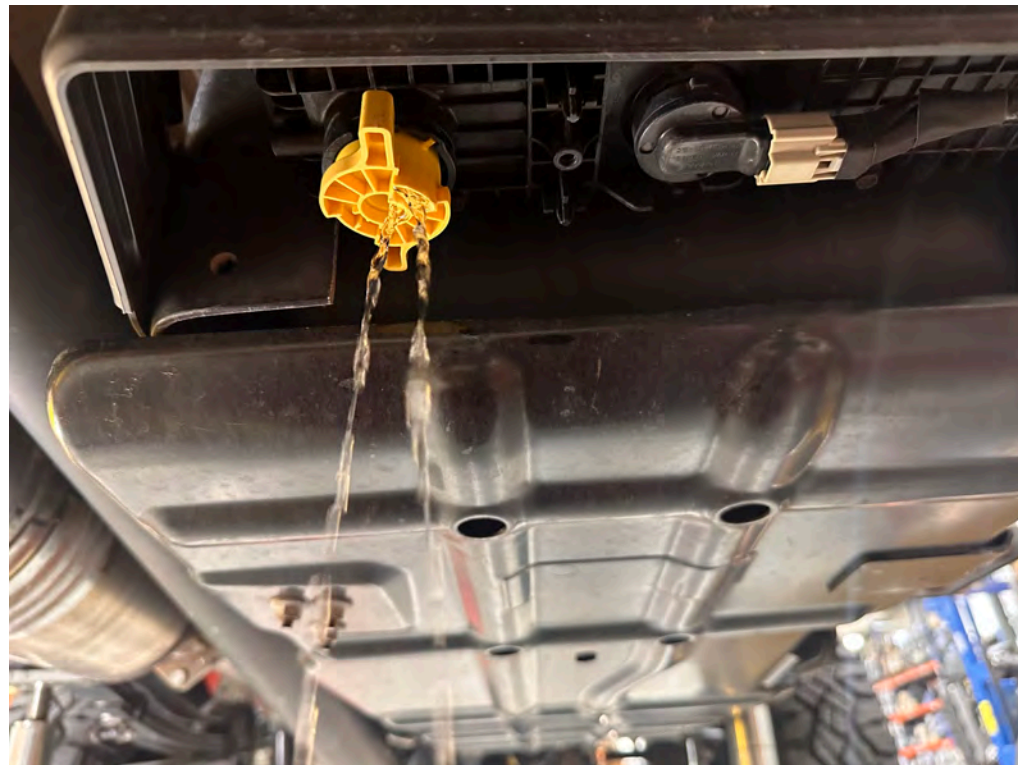
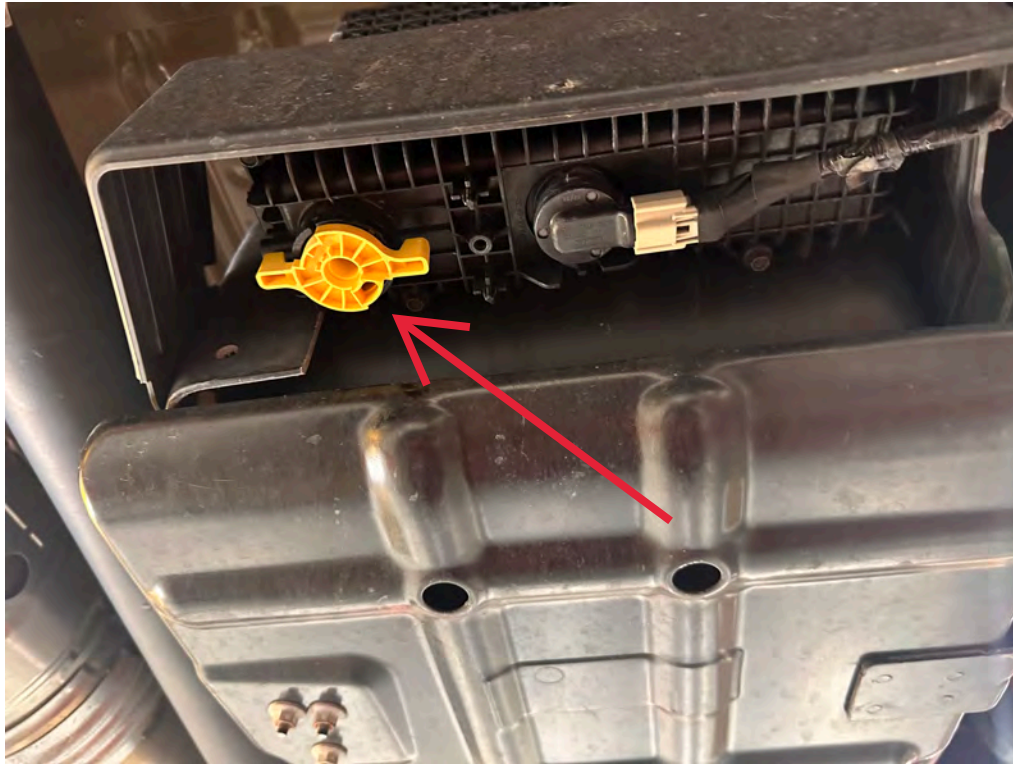

**STEP 3:**  
**PREPARE SUCTION & RETURN LINES**

- B. Release the locking tab on the water in fuel sensor and disconnect.

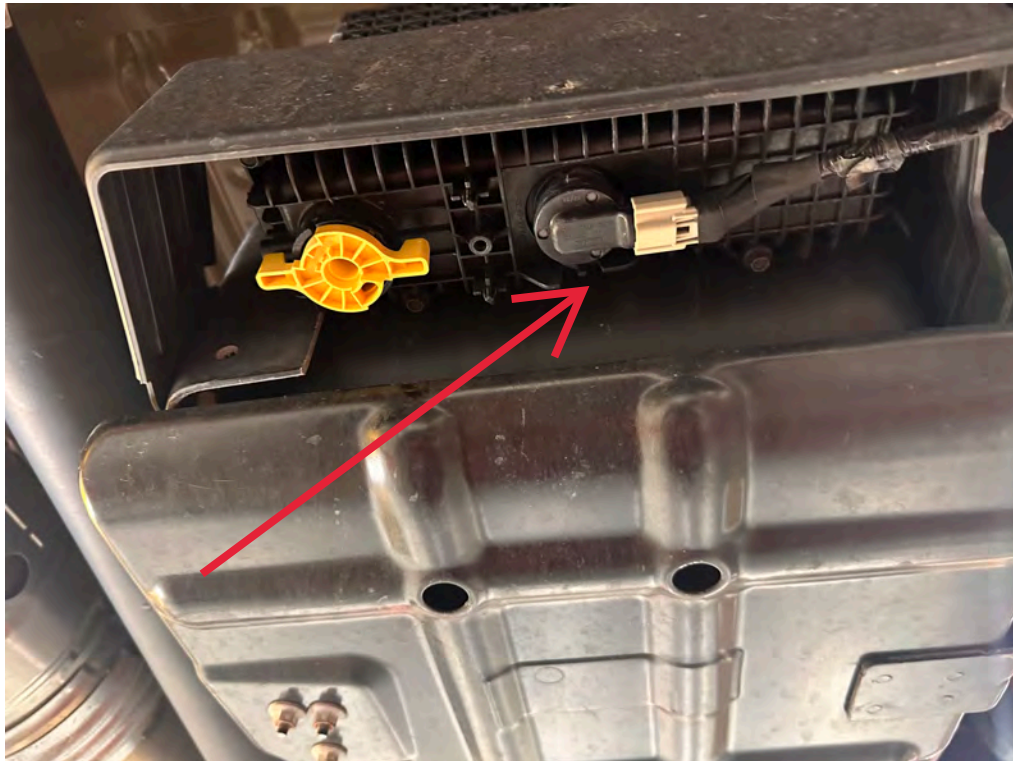



**STEP 3:**  
**PREPARE SUCTION & RETURN LINES**

C. Disconnect the OEM engine feed and return lines from the fuel conditioning module using the instructions in the beginning of this section.

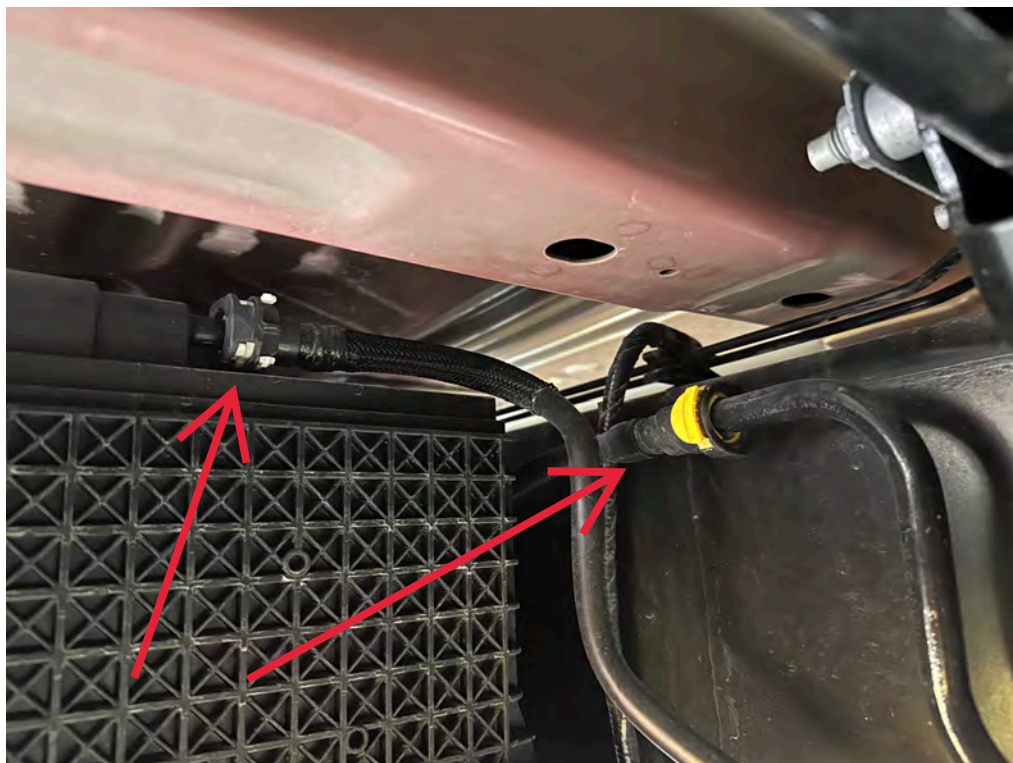

**STEP 3:**  
**PREPARE SUCTION & RETURN LINES**

D. Disconnect the 9th injector fuel feed line using the instructions in the beginning of this section.



**STEP 3:**  
**PREPARE SUCTION & RETURN LINES**

**E.** Remove the filler neck and overflow tubes from the truck by loosening the clamps at both ends.

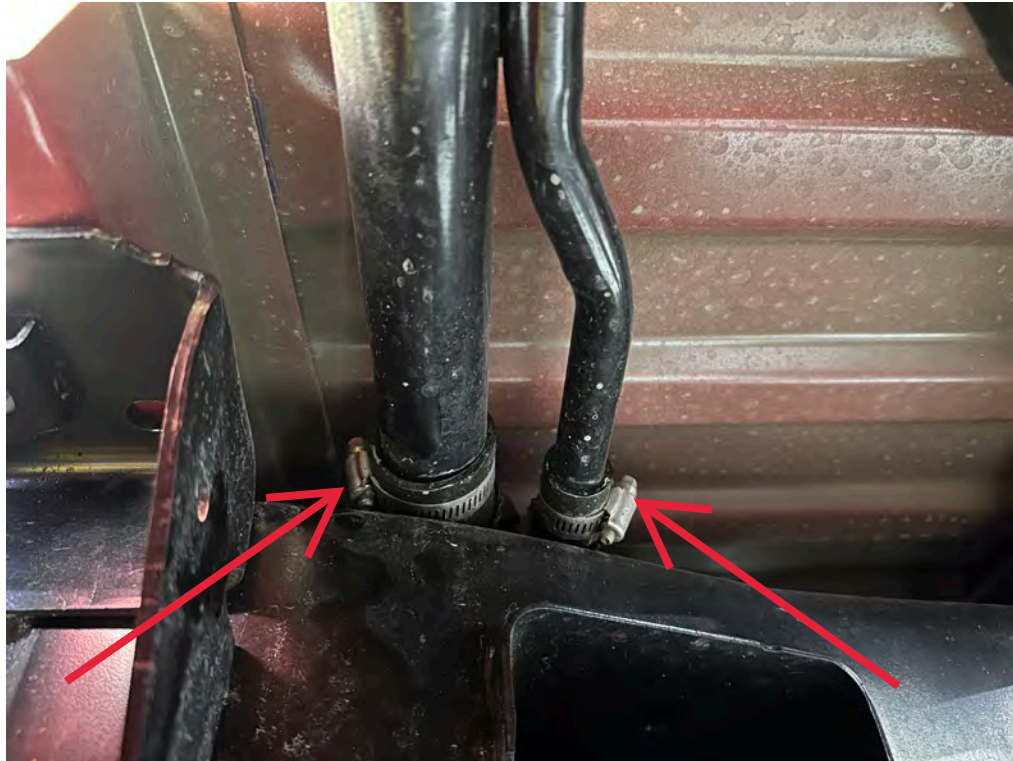

**STEP 3:**  
**PREPARE SUCTION & RETURN LINES**

- F. Release the locking tab on the fuel pump module connector and disconnect.



**STEP 3:**  
**PREPARE SUCTION & RETURN LINES**

- G. Remove the OEM fuel tank skid plate.



## **STEP 3:** **PREPARE SUCTION & RETURN LINES**

**H.** With the fuel tank empty of fuel, unbolt the tank straps and remove it from the vehicle. **REMOVE THE BOLTS BY HAND WITH A RATCHET TO PREVENT BREAKING THE NUT CLIPS**

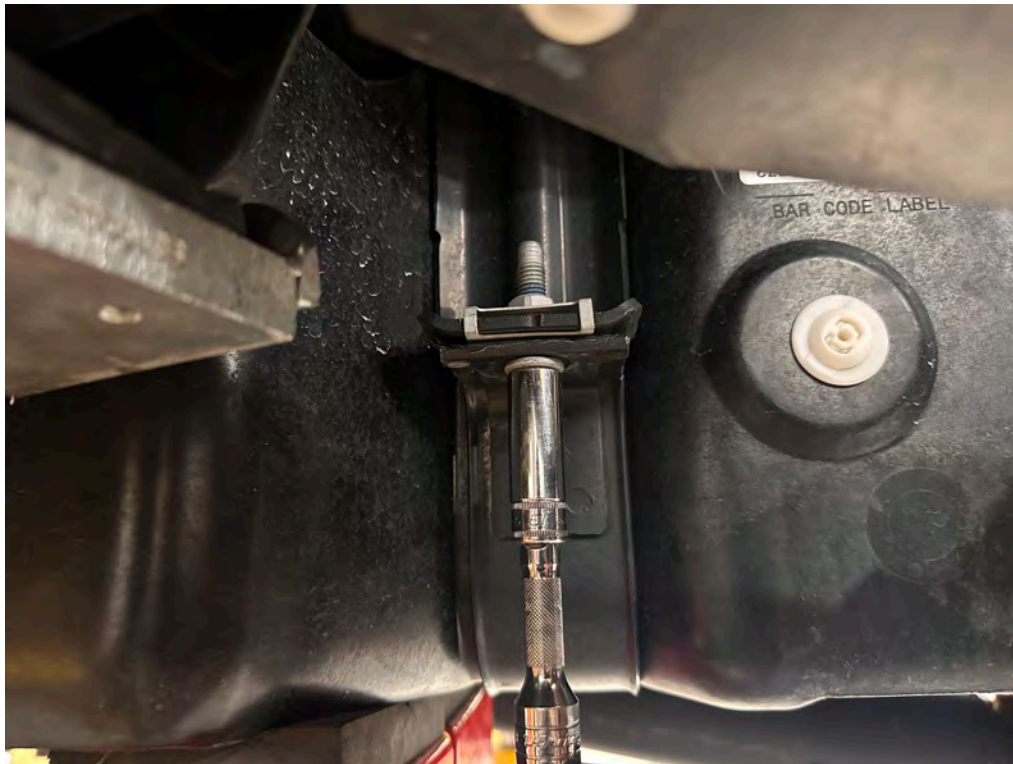

## **STEP 3:** **PREPARE SUCTION & RETURN LINES**

- I. Remove and discard the fuel tank module shield, this will no longer be used. Clean the fuel module area then disconnect all the OEM fuel fittings.



## **STEP 3:** **PREPARE SUCTION & RETURN LINES**

**J.** Remove the lock ring on the top of the fuel tank. This is spring loaded, so, holding it down while removing the ring will prevent the sending unit from popping up and possibly causing damage. Note the location of the tab and arrow. Re-install the sending unit in the same location to prevent the fuel level arm from binding. Remove fuel tank module from fuel tank, be careful not to damage fuel level float.

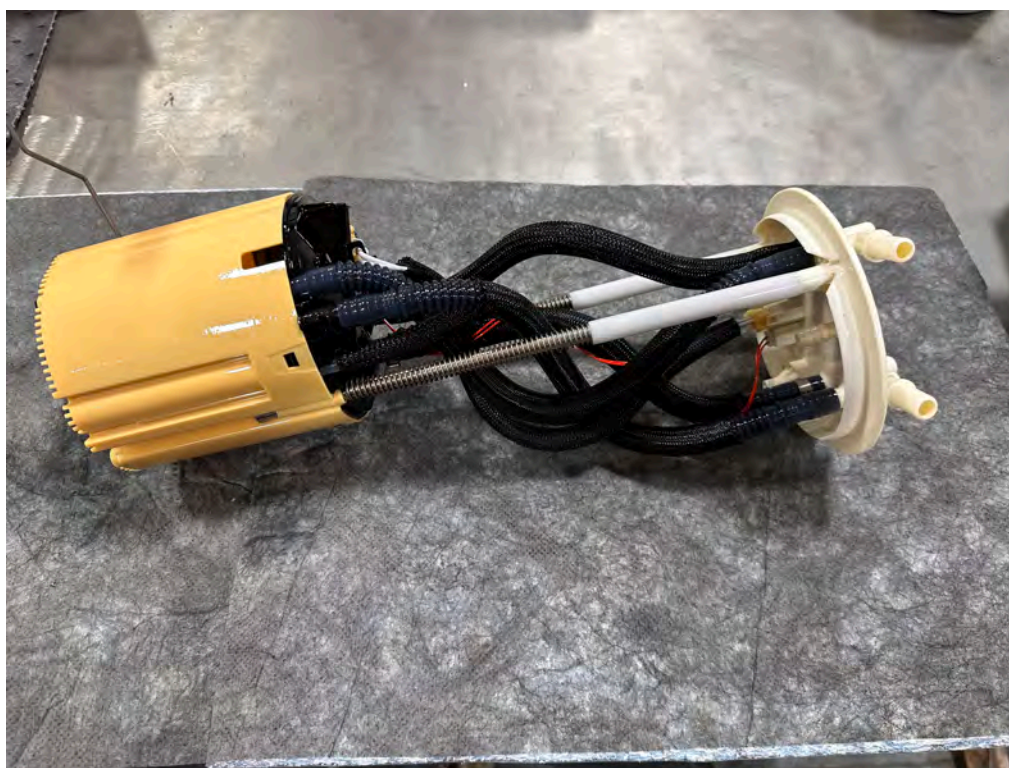



## **STEP 3:** **PREPARE SUCTION & RETURN LINES**

**K.** Remove OEM fuel pump harness from the fuel tank module by pressing clips on each side of the connector while pulling in an outward direction. Disconnect the fuel level sending unit electrical connector and remove the sending unit from the fuel tank module to prevent damage. **THIS WILL BE REINSTALLED AT A LATER TIME, DO NOT DISCARD!!!**

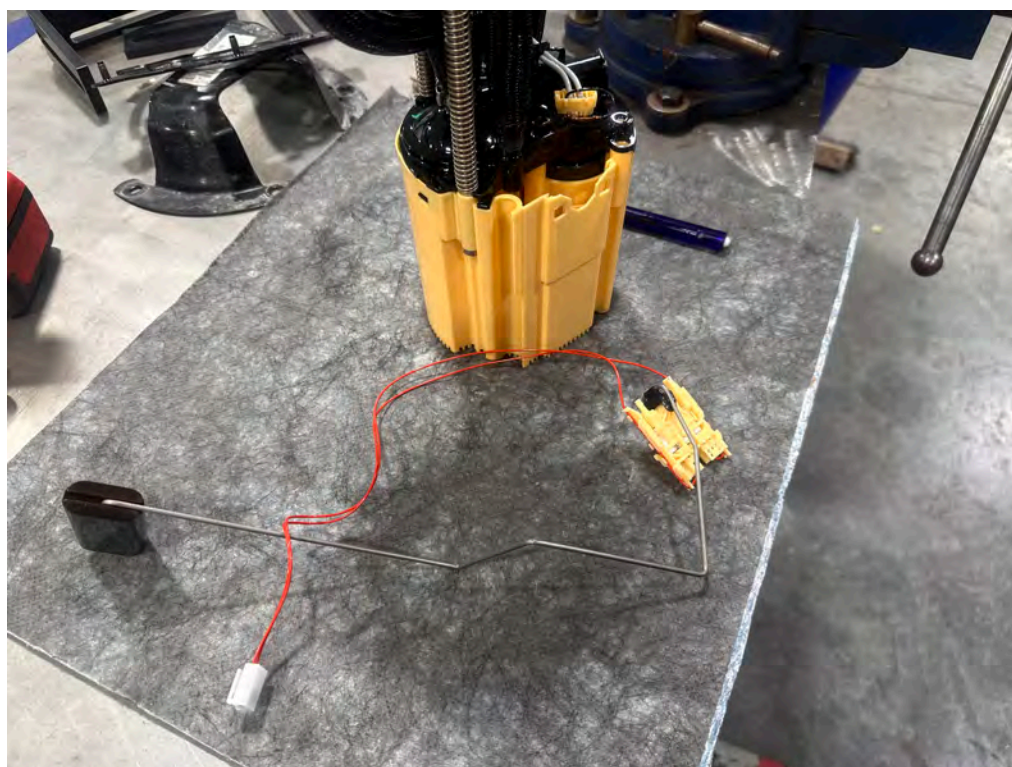
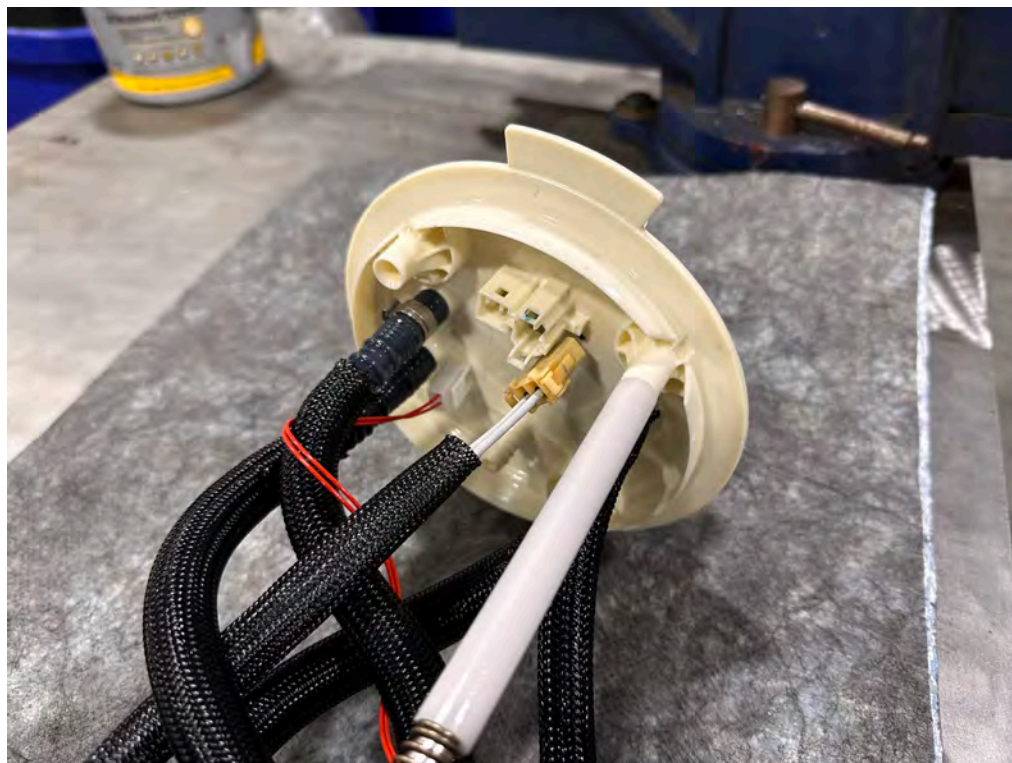

**STEP 3:**  
**PREPARE SUCTION & RETURN LINES**

L. Using side cutters, cut the venturi convoluted fuel line where pictured. **THIS WILL BE USED AT A LATER TIME, DO NOT FULLY REMOVE VENTURI LINE FROM FUEL MODUEL!!!**



## **STEP 3:** **PREPARE SUCTION & RETURN LINES**

**M.** Carefully remove the remaining sections of the OEM convoluted tubing from the fuel tank module using a utility knife. Be sure not to damage the hose barb beneath the convoluted tubing. One of the sections of tubing will have a metal clamp, this can be removed with a small pair of side-cutters.



**STEP 3:**  
**PREPARE SUCTION & RETURN LINES**

N. Using a pair of Vice-Grips, lift and retain the fuel tank module springs. Press the 3 locking tabs on the fuel tank module's lower section and remove.



## **STEP 3:** **PREPARE SUCTION & RETURN LINES**

- Using a 7/8" hole saw, drill the hole for BHF-1010 as pictured. **BE SURE TO DEBURR THE HOLE!!!**



**STEP 3:**  
**PREPARE SUCTION & RETURN LINES**

**P.** Install BHF-1010 onto the fuel tank module with OR-119, apply Loc-Tite onto threads and install BHN-1005 onto BHF-1010. Tighten BHN-1005 to BHF-1010 accordingly.

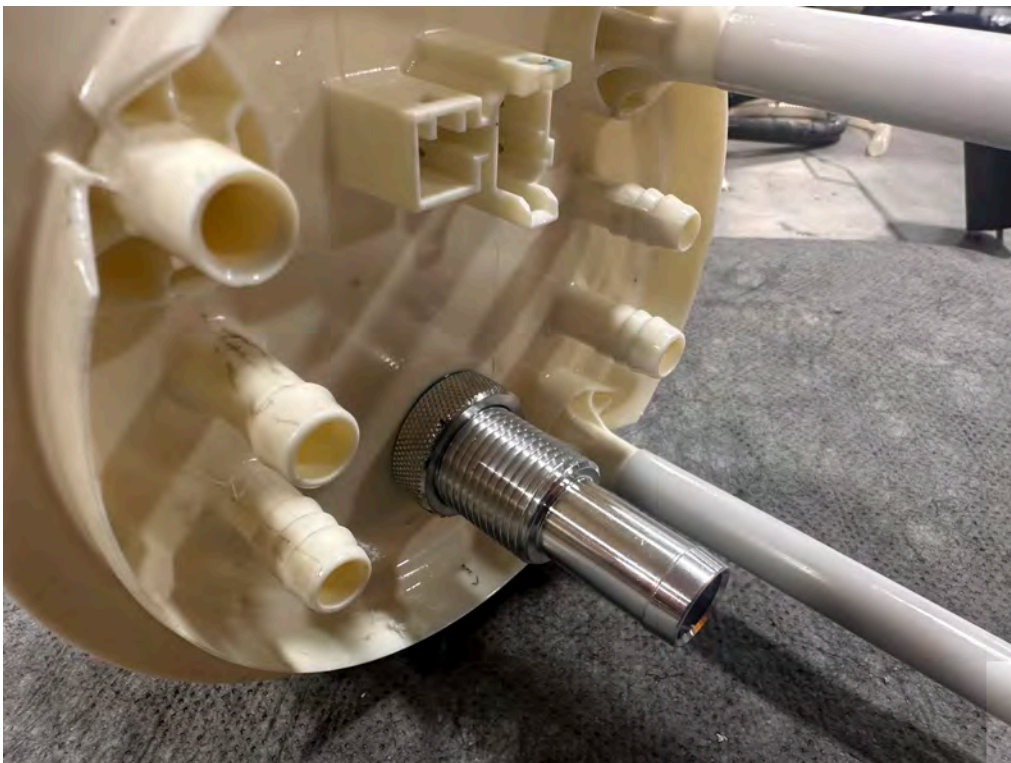

**STEP 3:**  
**PREPARE SUCTION & RETURN LINES**

Q. Using side cutters, cut the venturi line where the convoluted section ends as pictured.



**The image below shows the proper port configuration**

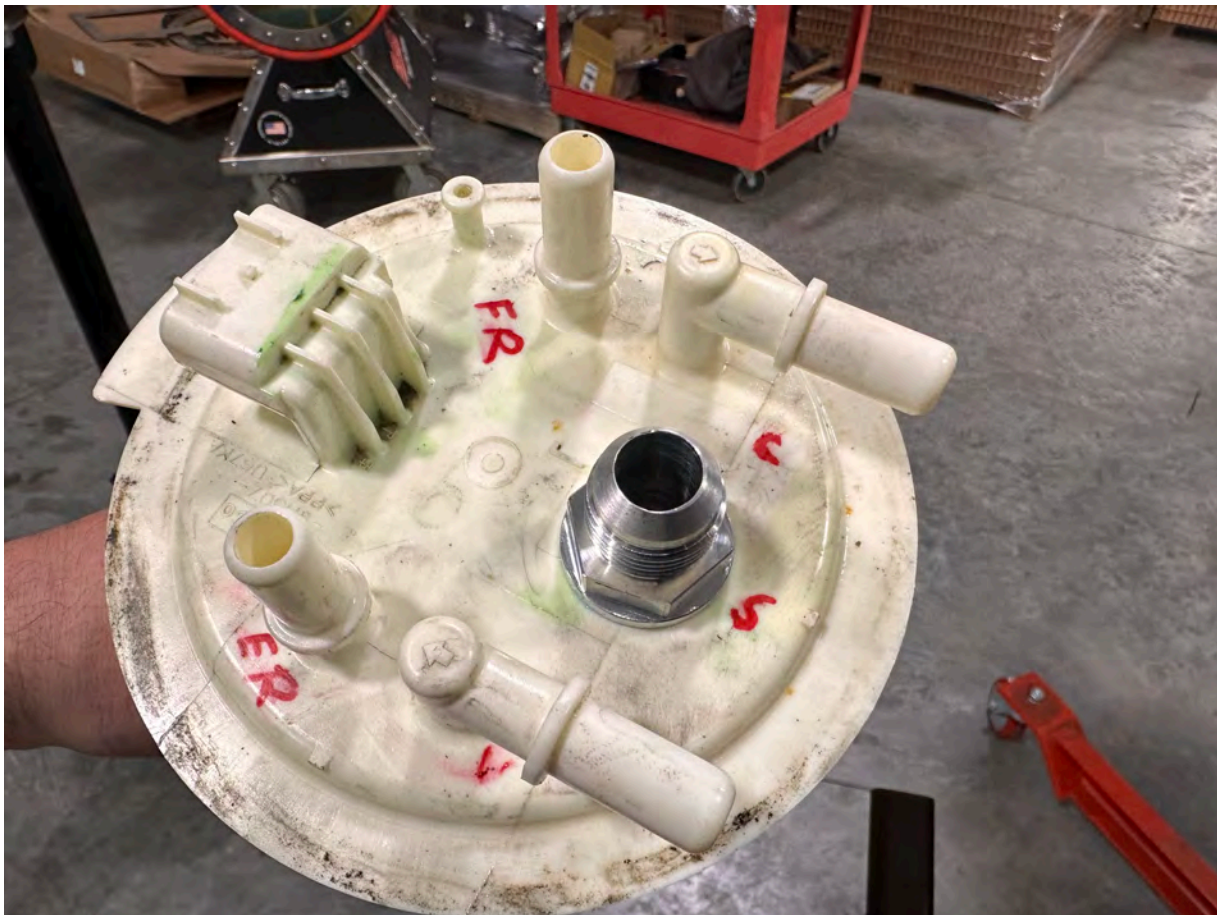

**FR = FASS RETURN  
C= CAP  
S= SUCTION  
V= VENTURI  
ER= OEM ENGINE RETURN**



**STEP 3:**  
**PREPARE SUCTION & RETURN LINES**

**R.** Using grease, install FL-1006 onto the OEM engine return barb and FL-1009 on the FASS RETURN barb. FL-1006 and FL-1009 may need to be trimmed to length.



**STEP 3:**  
**PREPARE SUCTION & RETURN LINES**

S. Using grease, press STF-1001 into FL-1007 with HC-1001, tighten hose clamp accordingly. **VERY IMPORTANT:** Support fuel tank on both ends allowing the natural formation of the tank to take place. Failure to perform this step will hinder precision installation.



**FUEL TANK SUPPORTS**

## **STEP 3:** **PREPARE SUCTION & RETURN LINES**

T. Using a tape measure, measure from the bottom of the fuel tank to the top of the o-ring sealing surface where the fuel tank module makes contact and take note of the measurement. **NOTE: ACTUAL MEASUREMENTS WILL VARY FROM IMAGES!**

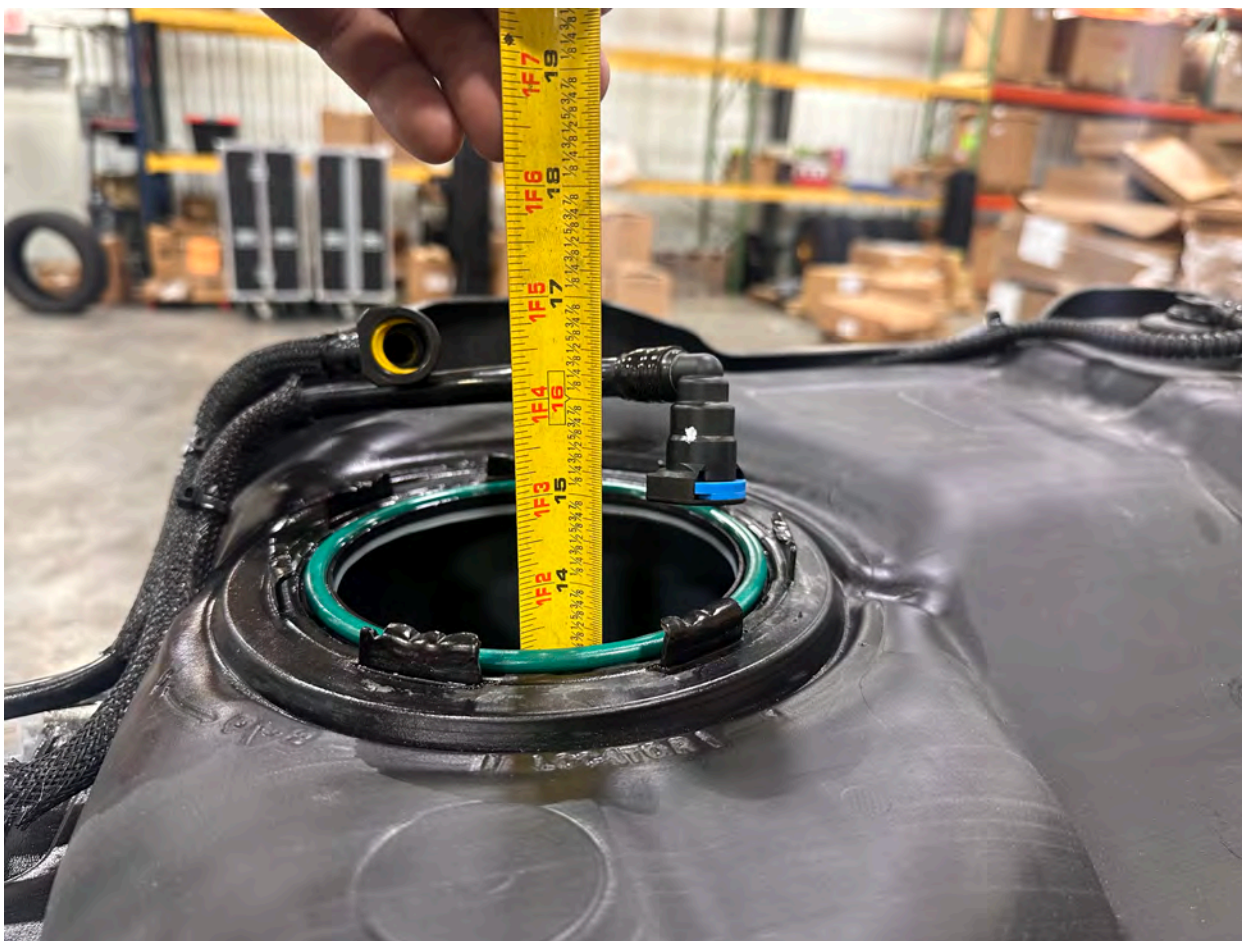

## **STEP 3:** **PREPARE SUCTION & RETURN LINES**

**U.** Compress fuel tank module to the exact height measurement taken in previous step, measure and mark FL-1007 with  $1/4$ - $1/2$ " clearance from bottom of fuel tank module. Cut FL-1007 to length. Using grease, install FL-1007 onto BHF-1010 with hose clamp HC-1001.



**STEP 3:**  
**PREPARE SUCTION & RETURN LINES**

V. Using grease, press HBRB-375-1875 into FL-1012 with HC-1001, tighten hose clamp accordingly.



**STEP 3:**  
**PREPARE SUCTION & RETURN LINES**

**W.** Using grease, press HBRB-375-1875 into OEM venturi line with VIB-12230, tighten hose clamp accordingly.



**STEP 3:**  
**PREPARE SUCTION & RETURN LINES**

X. Compress fuel tank module to where FL-1007 is 1/2" higher than in previous step, measure and mark FL-1012 and cut FL-1012 to length. Using grease, install FL-1012 onto VENTURI barb with hose clamp HC-1001 and tighten hose clamp accordingly.



**STEP 3:**  
**PREPARE SUCTION & RETURN LINES**

Y. Be sure the fuel level sensor is connected. Secure all hoses and wires together with provided cable ties and reinstall the module into the tank.

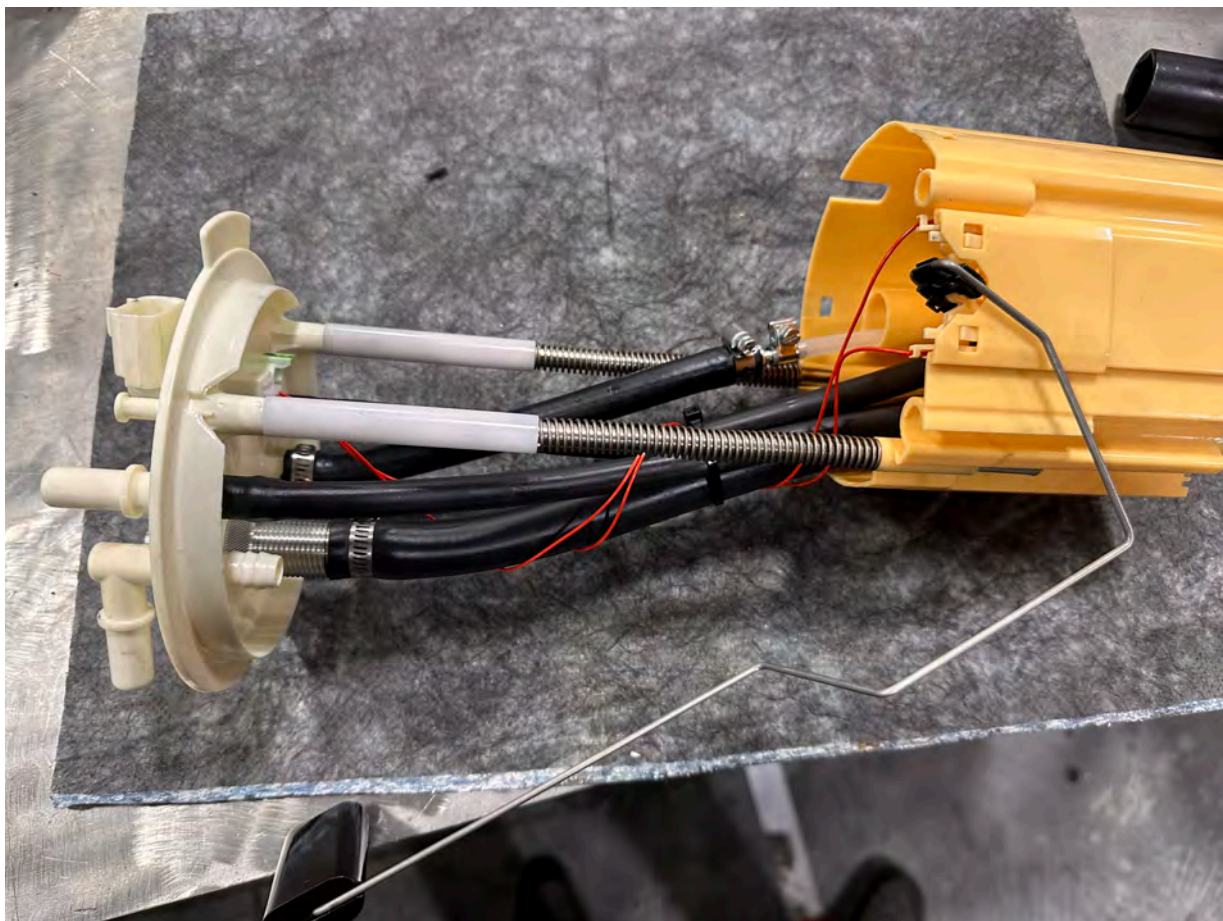



## **STEP 4:** **INSTALL FUEL LINES**

- A.** Using thread tape, install QC-4600 into both sides of 10-305 and tighten accordingly.



## **STEP 4:** **INSTALL FUEL LINES**

**B.** Disconnect the OEM fuel lines and install the previously assembled quick connect fitting to bypass the fuel conditioning module as pictured.

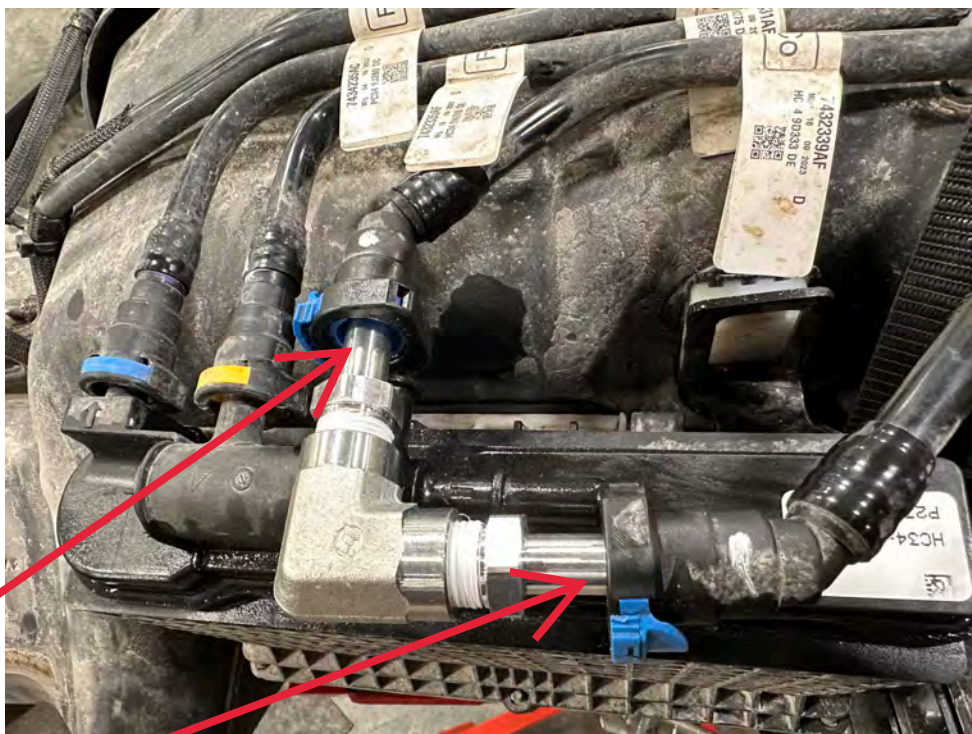

**TO SENDING UNIT**

**FUEL RETURN  
LINE FROM THE  
ENGINE**

## **STEP 4:** **INSTALL FUEL LINES**

**C.** Install the OEM engine return fuel line to the ER port and FFQC-500BFPC to the C port as pictured.



## **STEP 4:** **INSTALL FUEL LINES**

**D.** Using grease, press FL-1058-BK onto PL-2058-BK and install PL-2058-BK onto BHF-1010. Tighten accordingly.



## **STEP 4:** **INSTALL FUEL LINES**

**E.** Using grease, press a 66" piece of FL-1002-BK onto A624C56-55-05 with HC-1001. Install A624C56-55-05 onto the FR port as pictured.



## **STEP 4:** **INSTALL FUEL LINES**

F. Using thread tape, install PL-1013 and PL-500-125NPT into PLB-500-2X-1E-NPT. Tighten accordingly.



## **STEP 4:** **INSTALL FUEL LINES**

- G.** Using grease, press a 62" piece of FL-1002-BK onto one end of PLB-500-2X-1E-NPT and 56" piece on to the other end as pictured.



## **STEP 4:** **INSTALL FUEL LINES**

**H.** Using grease, press a 22" piece of FL-1002-BK onto PL-500-125NPT and FL-1011 on to PL-1013 as pictured.





## **STEP 4:** **INSTALL FUEL LINES**

**The image below shows the proper fuel line configuration**



## **STEP 4:** **INSTALL FUEL LINES**

I. Using grease, press A624A58-55-04 into FL-1002-BK with HC-1001 and install A624A58-55-04 onto the V port as pictured. FL-1002-BK may need trimmed to length

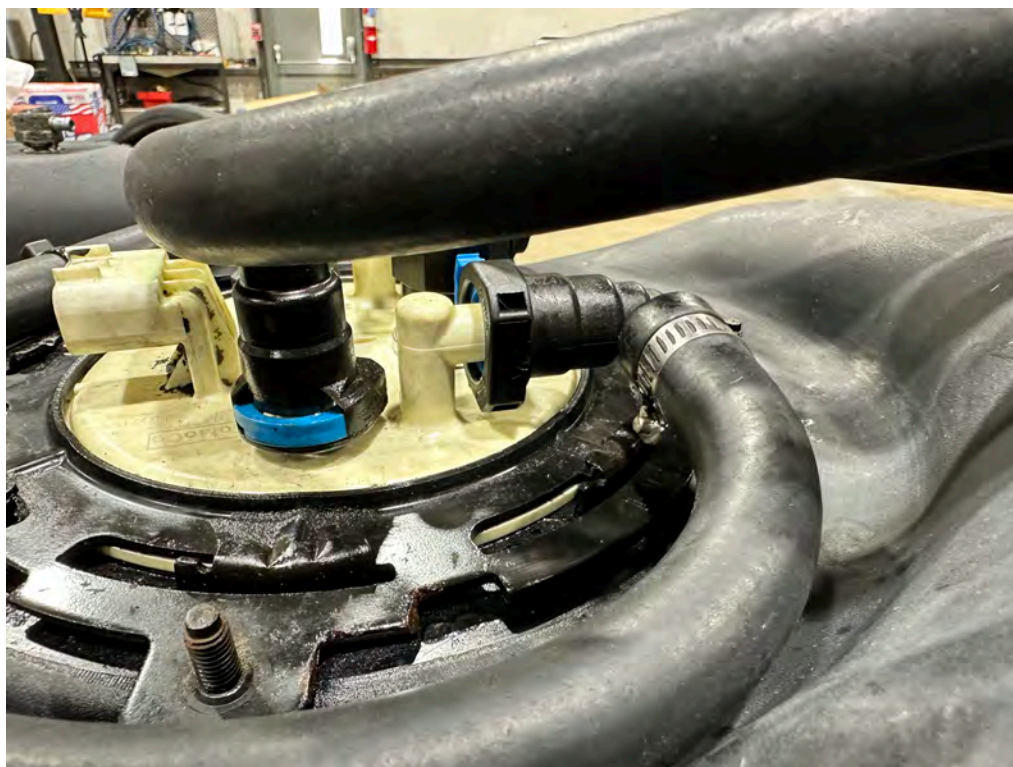

## **STEP 4:** **INSTALL FUEL LINES**

**J.** Route FL-1058-BK, FL-1011 and FL-1002-BK as pictured using the supplied cable ties. Reinstall the fuel tank and skid plate by reversing the steps taken for removal.



## **WARNING:**

The supplied 1,200°F heat shielding must be installed where FASS fuel line routes above the exhaust system. Failure to install heat shielding can result in a possible fire hazard!

***NOTE: Install heat shielding where fuel lines route above the exhaust system!***



## **STEP 4:** **INSTALL FUEL LINES**

**K.** Rout the 60" FL-1002-BK engine feed line to the OEM engine feed line and cut FL-1002-BK to length. Using grease, press A614C56-55-05 into FL-1002-BK with HC-1001 and connect to the OEM engine feed line.



## **STEP 4:** **INSTALL FUEL LINES**

- L.** Rout FL-1011 to the OEM 9th injector feed line and cut FL-1011 to length. Using grease, press A614A50G06-02 into FL-1011 with HC-4001 and connect to the OEM 9th injector feed line as pictured.



## **STEP 4:** **INSTALL FUEL LINES**

**M.** Rout FL-1058-BK to the T port on the FASS and cut FL-1058-BK to length. Using grease, press PL-2058-BK into FL-1058-BK and connect to AN-90-10-ORB-10-BK. Tighten accordingly.



## **STEP 4:** **INSTALL FUEL LINES**

**N.** Route the engine feed and the FASS return line to the FASS and cut to length. Using grease, press PL-2003-BK into FL-1002-BK and connect the engine feed line to the E port on the FASS and the FASS return line to the R port on the FASS. Tighten accordingly.





## **STEP 4:** **INSTALL FUEL LINE**

- Connect electrical connector on the FASS to the WH-1006-3, turn the key to the "RUN" position and spray WD-40 into the suction side of the FASS. This will allow easier priming of the FASS System.



**NOTE: SECURE ALL FUEL LINES AND ELECTRICAL COMPONENTS AWAY FROM ANY MOVING PARTS USING THE SUPPLIED CABLE TIES!!!**

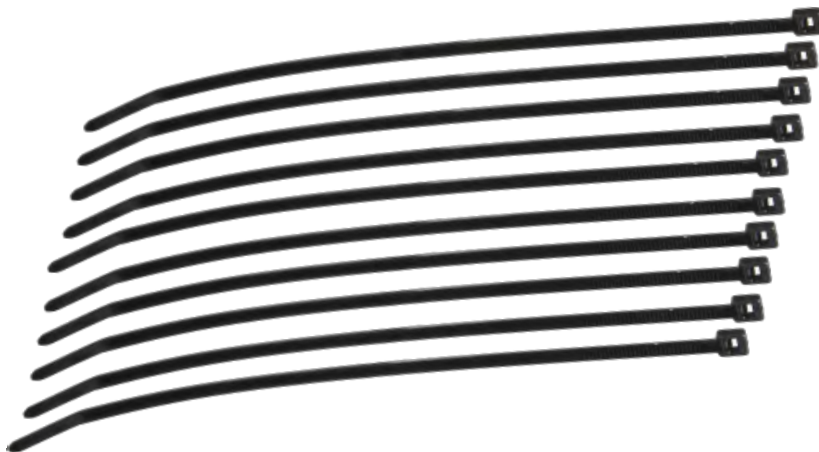

## **STEP 5:** **REVIEW INSTALLATION**

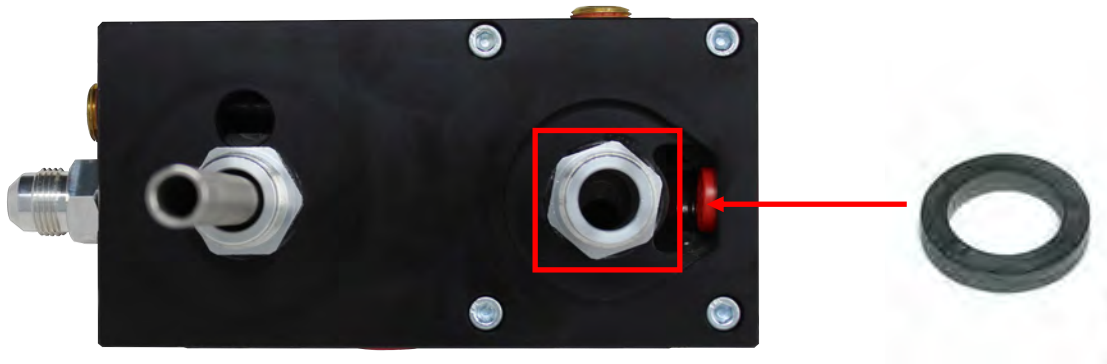

**Note: O-Ring must be put back on suction side of pump. Failure to do so can result in priming issues, cavitation, or pressure losses.**

1. **Blow out any open lines/cover any open ports**
2. **Bolts and fasteners properly tightened?**
3. **Electrical harness and fuel lines secured and properly tightened? Reconnect the battery.**
4. **Has the system been primed?**
  - a. **Turn key to the ignition position, turning on the FASS pump for 15 sec..**
  - b. **Crank engine and allow to run for at least 1 minute.**
5. **Check for leaks.**
6. **Start the engine**
7. **Recheck all fluid and filter connections for leaks**
8. **This pump comes with a 1 Year Manufacturer's Warranty based on the date it has been manufactured. To receive your extended Lifetime Warranty, you have 30 days from date of purchase to send the completed warranty information**



[www.fassride.com](http://www.fassride.com)

(866) 769.3747

## LIMITATION OF LIFETIME WARRANTY

Disclaimer: To help insure you receive the proper system and customer support at the local level, FASS has a VIP and Authorized Dealer network representing FASS products. This is one reason you must purchase through a dealer to comply with our warranty policies. If you do not, there is no warranty! We recommend you go to [www.FASSride.com](http://www.FASSride.com), click "Find a Dealer", put in their ZIP code, select the type of dealer, and see if the company you purchased from is listed. If they are not, put their phone number in the field below the ZIP code field to see if they are listed. Below these two fields is a list of "Terminated/Unauthorized" dealers. You may want to review this list. If the company is not listed or is on the "Terminated/Unauthorized" list, we suggest you return the product immediately to that dealer and call FASS. We'll recommend you to the nearest dealer.

Diesel Performance Products, Inc. (hereafter "SELLER") gives Limited Warranty as to description, quality, merchantability, fitness for any product's purpose, productiveness, or any other matter of SELLER'S product sold herewith. The SELLER shall be in no way responsible for the product's open use and service and the BUYER hereby waives all rights other than those expressly written herein. This Warranty shall not be extended or varied except by a written instrument signed by SELLER and BUYER.

When MANUFACTURER receives the "ORIGINAL" PRODUCT REGISTRATION form with a copy of the "BILL OF SALE/SALES RECEIPT" within 30 days of the sale, then the following applies! The Warranty will then and only then be validated to that of which typically accompanies your unit for your specific application from the date of sale or for recommended service life and limited solely to the original purchaser and/or vehicle and parts contained within the product's kit. This warranty does not cover normal wear on consumable items such as but not limited to filters, fuel line, wire harness & etc. The warranty does not cover seized gears due to lack of filtration. Warranty is voided if used with other than diesel fuel. Returned items will arrive prepaid to the place of purchase. Diesel Performance Products, Inc. will repair, without cost, any product found to be defective during the warranty period; parts only, or at its option, will replace such products in exchange for the product. Repair or replacements are warranted for the remainder of the original warranty period. All Warranty claims are subject to approval by Diesel Performance Products, Inc.

A Return Material Authorization (RMA) number must be obtained before any product is to be returned to Diesel Performance Products, Inc. for warranty consideration, repair or product return. Requests for product returns must be offset by an equal value order. Return parts must be completed and in resalable condition. No returns after 30 days.

The following information is required to obtain a RMA number before returning product:

Your Name, Address, and Phone Number's

Model and Serial Number (Not Motor Number) Example: Model HD Series, Serial: 00125966 VIN Number of Vehicle

Date of Purchase

Nature of Problem

RMA and Product Serial Number must be on all paperwork and correspondence. Failure to obtain the required information or paperwork will result in \$25.00/item penalty and delay or denial of any warranty claim.

Under no circumstances shall the SELLER and/or MANUFACTURER be liable for any labor charged or travel time incurred in diagnosis for defects, removal, or reinstallation of this product, or any other contingent expenses.

Under no circumstances shall the SELLER and/or MANUFACTURER be liable for any damage or expenses incurred by reason of the use or sale of any such equipment. This warranty does not apply to products which Diesel Performance Products, Inc. has determined to have been misused or abused, improperly maintained by the user, or where the malfunction or defect can be attributed to the use of non-genuine Diesel Performance Products, Inc. parts.

IN THE EVENT THAT THE BUYER DOES NOT AGREE WITH THIS AGREEMENT: THE BUYER MAY PROMPTLY RETURN THIS PRODUCT, IN A NEW AND UNUSED CONDITION, WITH A DATED PROOF OF PURCHASE, TO THE PLACE OF PURCHASE WITHIN THIRTY (30) DAYS FROM DATE OF PURCHASE FOR A FULL REFUND LESS SHIPPING.

THE INSTALLATION OF THIS PRODUCT INDICATES THAT THE BUYER HAS READ AND UNDERSTANDS THIS AGREEMENT AND ACCEPTS ITS TERMS AND CONDITIONS.