



# INSTALL INSTRUCTIONS FOR 75-5197



## BEFORE YOU START

This intake kit may not fit with the following aftermarket parts installed: Body Lift or Lowering Kit, Custom Hood, Intercooler or Turbo upgrades.

## REQUIRED TOOLS

7mm, 8mm, 10mm, and 13mm Socket and Wrench, 10" Socket Extension or 4" + 6" Socket Extensions, 13mm Open/Box Combination Wrench, 5/16" Nut Driver, T20 Torx Bit/Driver, Panel Popper, Phillips Screwdriver, Wire Cutters.



Hi. Need any help?



ITEM NO.	PART NUMBER	DESCRIPTION	QTY.
1	AL13708-00	Airbox	1
2	AI2477-00	Bracket, Front Scoop	1
3	AI1650C-00	Tube Seal	1
4	AL1449-00	Intake Tube	1
5	KF-1050	Air Filter	1
6	AI1214-00	HHCS, M8-1.25 x 25mm Long, Class 8.8, Zn Pltd	2
7	AI1563-00	Grommet, 1/2" ID x 1-1/16" OD, 7/16" Thk, 3/16" Panel	2
8	AI1473-00	Pan Head Phil Mch Screw, M4 x 10mm long, SS	3
9	AI2452-00	Hex Flange Bolt, M6 x 10mm Long, Steel, Zn Pltd	2
10	AI2296-00	Bushing, Shoulder, Aluminum	2
11	AI2453-00	Washer, Flat, 1/4", 1.00" OD, Steel, Zn Pltd	1
12	AI2475-00	Bracket, Airbox	1
13	AI1961-00	Foam Filter	1
14	AI1960-00	Foam Retainer	1
15	AI1762-00	Plastic Rivet, Interlocking Shank, 1/4" dia	2
16	AI1956C-00	Scoop	1
17	AG1010-00	Hose Clamp, #80	1
18	AI2478-00	Clear Lid	1
19	AI2465C-00	Snap-In Lid Seal	1
20	AI2464C-00	Air Box Plug	1
21	AI3318C-00	Throttle Coupler	1
22	AG1008-00	Hose Clamp #64	2
23	AI3319-00	Quick Connect, 3/8 NPT to 5/8"	2
24	AI1822-00	MAF Pad	1
25	AI1823-00	MAF Gasket	1
26	AI1837-00	Screw, SEMS, Pan Head, Phillips, #8-32 X 3/4, SS	2
27	AI1750-00	Cable Tie, 9" Long	5

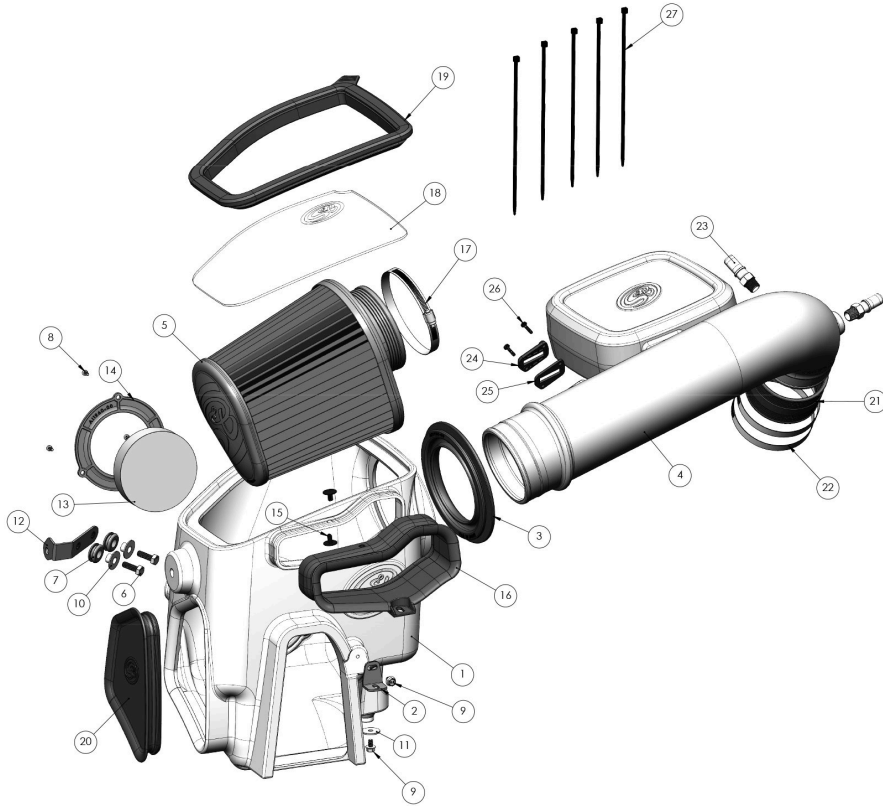

## IMPORTANT VERIFICATION.

IMPORTANT: Verify you have this lid seal. If you do not have the correct lid seal (AI2465C-00), please contact us at 909-947-0015.



## STEP 1

After waiting for two hours with the battery disconnected and the engine turned off to allow it to cool down, open the hood and begin the installation.

IMPORTANT: Failure to disconnect the battery for a minimum of 2 hours may cause the Check Engine Light to illuminate upon completion of the installation or subsequent operation. **Do not skip this step!**

## STEP 2

Disconnect the MAF sensor electrical harness by disengaging the white locking clip, pressing down on the tab, then pulling away from the MAF sensor.



## STEP 3

Remove the ribbed push-in clip on the wiring harness from the stock intake lid.  
Tools Required: Panel Popper or Flat Blade Screwdriver.

## STEP 4

Loosen the hose clamps on the intake tube connected to the throttle body. Tools

Required: 7mm

Socket/Wrench or Flat Blade.

## STEP 5

Disconnect the vent lines from the stock intake tube. Please watch our install video if you have questions on how to remove the quick connects.



## **STEP 6**

Unhook the three clips on the stock intake box lid.

## **STEP 7**

Remove the stock intake box lid and tube from the vehicle.

## **STEP 8**

Carefully remove the stock intake filter.

## **STEP 9**

Pop out the stem and remove the push-in rivet securing the stock front inlet. Set the push-in rivet aside, it will be reused.

## **STEP 10**

With a 8mm socket and extension, remove the bolt holding the front of the intake to the vehicle. Then remove the intake box from the truck.

## **STEP 11**

Remove the two bolts that hold the saddle bracket and remove the bracket from the vehicle. Set the screws aside, they will be reused Tools

Required: 13mm

Socket/Wrench Tools

Required: 13mm

Socket/Wrench.

## **STEP 12**

Install the Washer to the  
bottom of the Air Box using  
Hex Flange Bolt Tools  
Required: 10mm  
Socket/Wrench or Box/Open  
Wrench



## **STEP 13**

With a 10mm socket install the bracket onto the front of the airbox

## **STEP 14**

Install foam inserts into the airbox. The plastic plate will hold the foam in place.

## **STEP 15**

Install Grommets to the Air Box Make sure that Air Box is fully seated into the groove of both Grommets and that both sides of the Grommets are flat against the wall of the Air

Box. Install the shoulder washers from the inside of the box through the grommets.

## **STEP 16**

Install the S&B tube seal into the S&B airbox

## **STEP 17**

Install the Air Box Bracket onto the fender using the threaded hole (closest to the battery) of the saddle bracket removed. Reuse one saddle bracket screw removed previously and hand tighten

only. Tools Required: 13mm  
Box/Open Wrench.



## STEP 18

Carefully work the Air Box into the vehicle. The space is tight but carefully move/rotate the box to make space for the grill inlet duct, fender, and coolant reservoir as you lower the Air Box.

Once the Air Box is below the fender it will become easy to position the Air Box properly then push down to fully seat the Washer into the stock bottom box grommet. The Air Box should snap into the grommet.



## STEP 19

With a 8mm socket, reinstall the factory bolt.



## STEP 20

Position the Air Box so that the hole in Air Box is in line and matched with the threaded hole in the fender frame and the holes in the Shoulder Bushings are also in line and matched with the threaded holes in Air Box Bracket. Rotate the Air Box Bracket as required.



Install the included (2) S&B bolts and (1) OEM bolt and tighten.

## STEP 12

Remove the MAF sensor from the stock intake box. Tools Required: T20 Torx Bit/Driver.

### **STEP 13**

Using the MAF gasket and MAF plastic pad install into the S&B intake tube with the included longer Phillips head bolts.

### **STEP 14**

Tighten until the gasket is compressed.

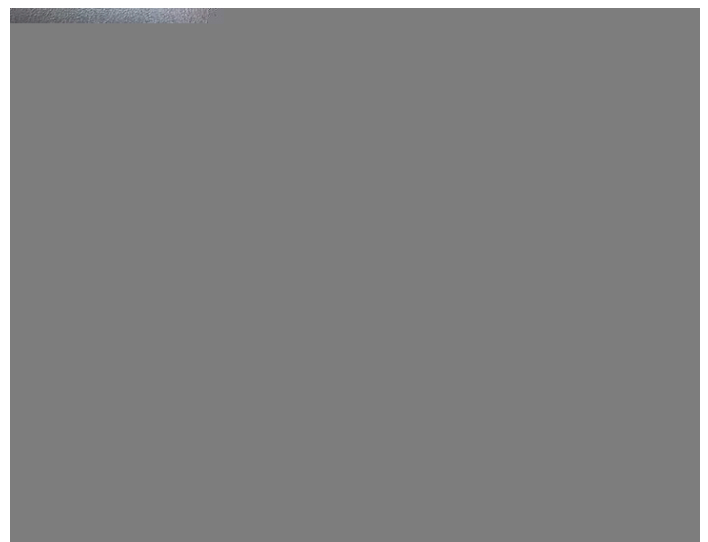

## STEP 15

Thread the quick-connect fittings onto the tube by hand.



## STEP 16

Tighten the quick-connect fittings onto the tube using a wrench. Do not over-tighten. It is normal for threads to still be showing on the fittings.



## STEP 17

Install the coupler onto the intake tube with the hose clamps loose.



## STEP 18

Install the intake tube through the airbox and rotate the tube down until the coupler is on the throttle body and the resonator mounting stud is seated.



## STEP 19

Reconnect the quick connect fittings and tighten the hose clamps.



## STEP 20

Attach the Air Box Inlet to the Air Box.

## STEP 21

Squeeze the Plastic Rivets together so they lock into place through the airbox and Air box inlet.



## **STEP 22**

Install the factory push rivet.

## **STEP 22**

Install the air filter onto the intake tube and tighten down

## **STEP 23**

Reinstall the MAF sensor and push the Christmas tree zip tie into the hole on the airbox.

## STEP 24

Peel off the protective covering on the clear Lid. Don't forget to remove the protective covering around the S&B logo.

## STEP 25

Install the Lid Seal around the outside edge of the clear Lid. Install the clear Lid with Lid Seal onto the Air Box. Start by inserting the Lid Seal groove over the Air Box opening on one corner first, then work your way around the Air Box. Make sure that the Lid Seal groove snaps over the entire Air Box opening. Check all around the Lid Seal snap groove to make sure it has snapped over the entire Air Box opening.



## STEP 26

To prevent the PCV lines from rubbing, zip tie the (2) together like shown.



## STEP 27

Reconnect the negative terminal on the battery



## STEP 28

Inspect your installation, and ensure the kit is positioned correctly and all fasteners and hose clamps are secured. Keep all stock parts if you ever need to reinstall the stock intake assembly. Affix the ID label near the Intake

kit. If you are an installer, give the owner the QR code for the Installation Instructions so that he/she is aware of the Maintenance and Operation procedures are given at the beginning of the Instructions. The installation is now complete.

