

Installation Instructions

K4354A

2003-2006 Ford 6.0L Excursion 4" Alum Kit Cat Back

Tools needed: 9/16" end wrench or socket, 7/16" deep socket, hacksaw or sawzall, aerosol lubricant.

(If your vehicle is equipped with a catalytic converter, it is unlawful to remove.)

(Check local laws concerning exhaust modifications)

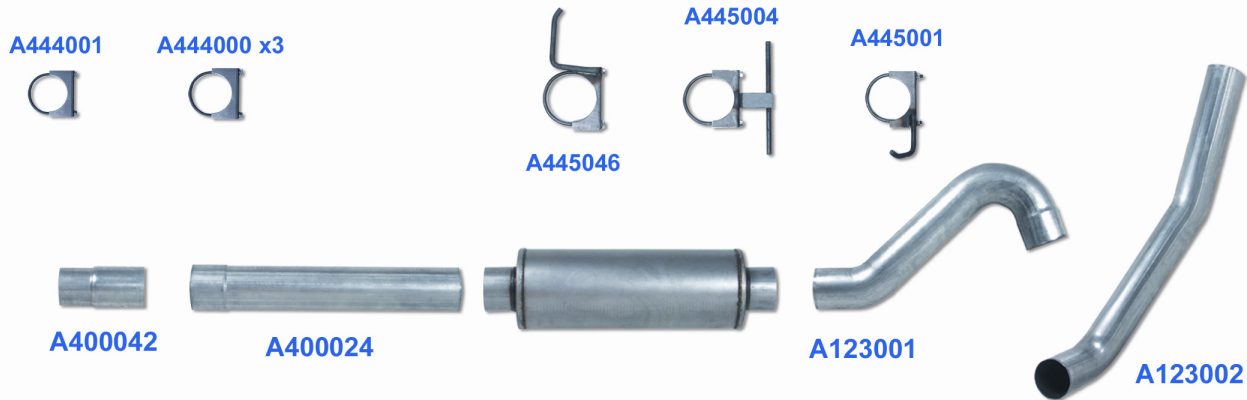

Removal of Original System

We suggest that a trained professional remove and install your exhaust.

- 1) Start under the vehicle. Remove the band clamp that holds the stock system to the converter by loosening the bolt and gently prying the clamp loose. If the clamp will not release continue to next step. When you have the rest of the system off shake the pipe from underneath the vehicle this will break the seal and you will hear the clamp release. Gently remove the clamp and save for the reinstallation.
- 2) Cut the original system just behind the muffler.
- 3) Spray the stock hangers with aerosol lube and pry rubber mounts from the system. Leave the rubber mounts attached to the truck for re-use.
- 4) Remove the old system from the cat back.

Installation of New Performance System

(Do not fully tighten any clamps until the complete system is installed and aligned.)

- 1) Hang the muffler in the stock location using the hanger clamp on the outlet. This determines the placement of the rest of the system.
- 2) Install the first tail pipe into the outlet of the muffler using the hanger clamp already installed. Rotate the pipe as needed to pass next to the shock absorber and over the rear axle.
- 3) Install the second tail pipe into the outlet of the first tail pipe with a clamp. Rotate as needed to level the outlet behind the rear tire. Attach the hanger clamp in the stock location.
- 4) Attach the adapter to the outlet of the catalytic converter with the 3 1/2" bare clamp.
- 5) Measure between the outlet of the adapter and the inlet of the muffler. Add 5" to this measurement for the slip-joints and cut the straight pipe to fit. Install the cut pipe between the adapter and the muffler with a clamp at the front and a clamp on the muffler inlet. Install the hanger clamp in the stock location near the center of the straight pipe.
- 6) Starting at the catalytic converter, align and tighten all the pipes and clamps. Start the engine and check for leaks.