

# Installation Instructions

## K5344A

### 2003-2007 Ford 6.0L F250-F350 Cat Back 5"

Tools needed: 9/16" end wrench or socket, 7/16" deep socket, hacksaw or sawzall, aerosol lubricant.  
**(If your vehicle is equipped with a catalytic converter, it is unlawful to remove.)**

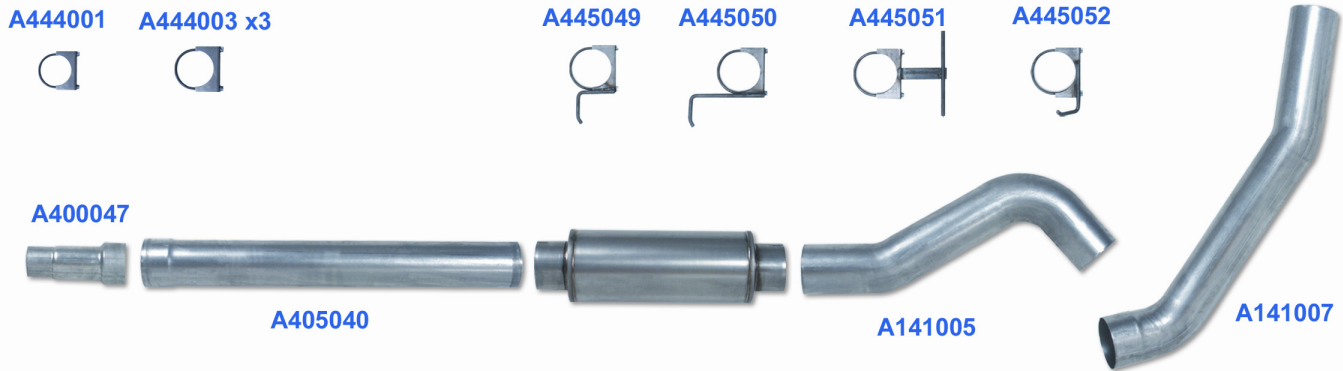

#### Removal of Original System

- 1) Start under the vehicle. Remove the band clamp that holds the stock system to the converter by loosening the bolt and prying the clamp loose.
- 2) Cut the original system just behind the muffler.
- 3) Spray the stock hangers with aerosol lube and pry the system from the rubber mounts. Leave the rubber mounts attached to the truck for re-use.
- 4) Remove the old system.

#### Installation of New Performance System

(Recommended Procedure: Do not fully tighten any clamps until the complete system is installed and aligned.)

- 1) From under the truck, install the 3 1/2"-5" adapter to the stock catalytic converter using a clamp.
- 2) Install the 40" straight pipe into the muffler inlet using a clamp.
- 3) Hang the muffler in the stock location using the hanger clamp on the straight pipe and the hanger clamp on the muffler outlet.
- 4) Install the first tailpipe section into the outlet of the muffler using the hanger clamp already installed.
- 5) Rotate the pipe as needed to pass next to the shock absorber and over the rear axle.
- 6) Install the second tailpipe into the outlet of the first tailpipe with a clamp. Rotate as needed to level the outlet behind the right rear tire. Attach the hanger clamp to the second tailpipe using the rubber in the stock location.
- 7) Measure between the outlet of the 3 1/2"-5" adapter and the inlet of the muffler. (Add 5" to this measurement for the slip-joints.)
- 8) Remove and cut the straight pipe and reinstall between the adapter and the muffler using a clamp at the adapter outlet and the muffler inlet.
- 9) Install the hanger clamp near the front of the straight pipe using the stock rubber.
- 10) Starting at the converter, align all pipes and tighten all clamps. Start the engine and check for leaks.