

Installation Instructions

K4320A

1999.5-2003.5 Ford 7.3L Dual 4''

Tools needed: 9/16'' end wrench or socket, 7/16'' deep socket, hacksaw or sawzall, aerosol lubricant.
(If your vehicle is equipped with a catalytic converter, it is unlawful to remove.)

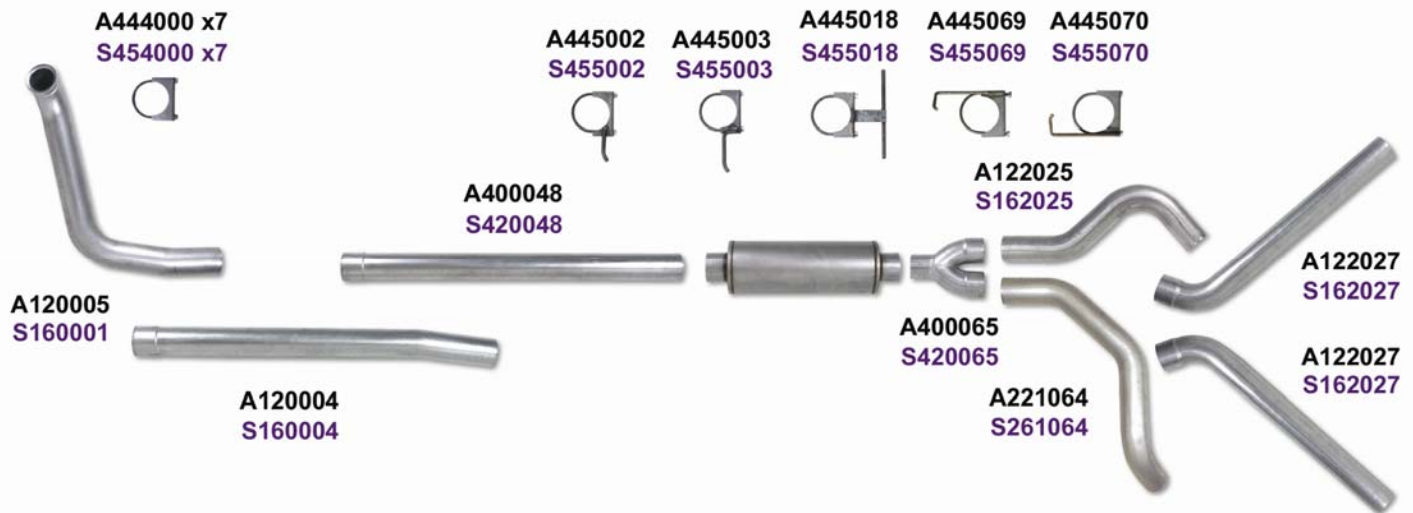

Removal of Original System

- 1) Start under the vehicle. Remove the band clamp that holds the stock down pipe to the turbo by loosening the nut on the "T" bolt and prying the clamp loose at the 3 pinch points. Save this clamp for re-use.
- 2) Cut the original system in two places, first next to the transmission and second, just behind the muffler.
- 3) Spray the stock hangers with aerosol lube and pry rubber mounts from the system. Leave the rubber mounts attached to the truck for re-use.
- 4) Remove the old system.

Installation of New Performance System

(Hint: Do not fully tighten any clamps until the complete system is installed and aligned.)

- 1) From under the truck, install the down pipe with the stock band clamp to the turbo.
- 2) Install the "Y" pipe into the outlet of the muffler with a clamp. (The "Y" pipe is installed vertically.) Hang the muffler in the stock location using the hanger clamp on the upper outlet of the "Y" pipe. This determines the placement of the rest of the system.
- 3) Install the drivers side 1st section tail pipe into the upper outlet of the "Y" pipe using the hanger clamp already installed. Rotate the pipe as needed to pass next to the shock absorber and over the rear axle on the driver's side.
- 4) Install the passenger's side 1st section tail pipe into the lower outlet of the "Y" pipe with a clamp. Rotate the pipe as needed to pass next to the shock absorber and over the rear axle on the passenger's side.
- 5) Install the 2nd section tail pipes into the outlets of the over-the-axle tail pipes with a clamp at each joint. Rotate as needed to level the outlet behind the rear tires.
- 6) Install the first hanger clamp on the passenger side tail pipe in the stock location. Install the hanger bracket in the existing hole in the frame rail on the driver's side. Install the rubber mount to the hanger bracket using the bolts supplied and attach the second hanger clamp.
- 7) Install the first straight pipe onto the outlet of the downpipe with a clamp. Install first the hanger clamp in the stock location.
- 8) Measure between the outlet of the first straight pipe and the inlet of the muffler. Add 5'' to this measurement for the slip joints and cut the second straight pipe to fit. Install the cut pipe between the first straight pipe and the muffler with a clamp at front and a clamp on the muffler inlet. Install the second hanger clamp in the stock location.
- 9) Starting at the turbo, align and tighten all the pipes and clamps. Start the engine and check for leaks.

Rev. MPN 6-25-07

****Disclaimer****

This application was designed as a performance cosmetic upgrade. Towing a 5th wheel or bumper tow trailer with more than 500 lbs. tongue weight may result in damage to your vehicle and/or the exhaust system.