

INSTALLATION INSTRUCTIONS

Front Windshield: IN-FWS-K-MULEFXR

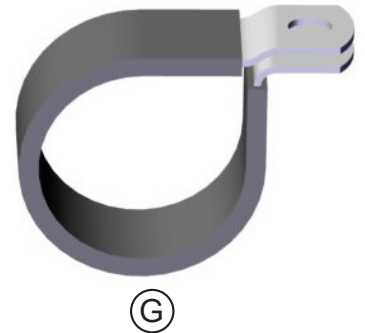
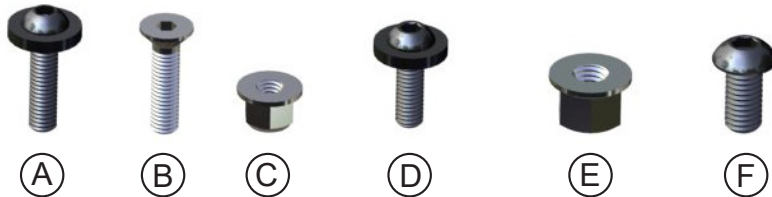
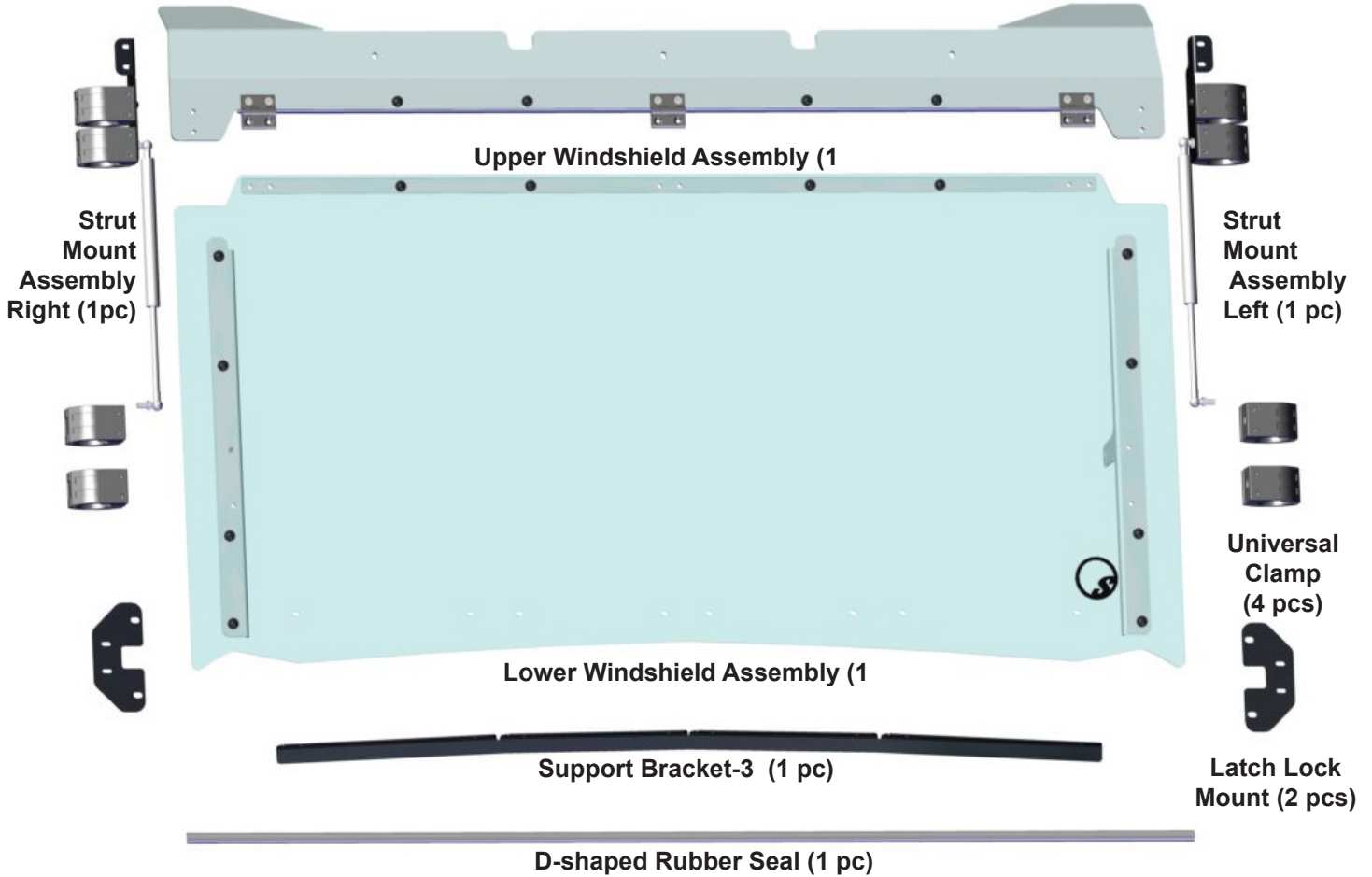

	Description	
A	M6x25 Seal Washer Bolt	11
B	M6x25 Flat FT Bolt Blk	6
C	M6 Nylock Nut	25

	Description	
D	M6x20 Seal Washer Bolt	8
E	M8 Nylock Nut	2
F	M8x16 Button FT Bolt	4

	Description	
G	1.75" Tube Clamp	3

What You'll Be Doing

- First Install Latches
- Install Support Bracket
- Install Rubber Seals
- Install Cylinder Assy's
- Install Lower Clamps & Bracket
- Install Tube Clips & Remove Roof Bolts
- Install Upper Panel
- Attach Cylinder Clamps
- Install Main Windshield
- Adjust Locking Clamps
- Hookup Cylinders
- Tighten Down All Bolts

1. The first thing you need to do is install the two side latches onto the windshield assembly. One on each side. You will install them using the M6x25 Sealing Washer Bolt, **Item "A"** and the M6 Nylock Nut, **Item "C"** provided in your kit. See **Fig.1**.

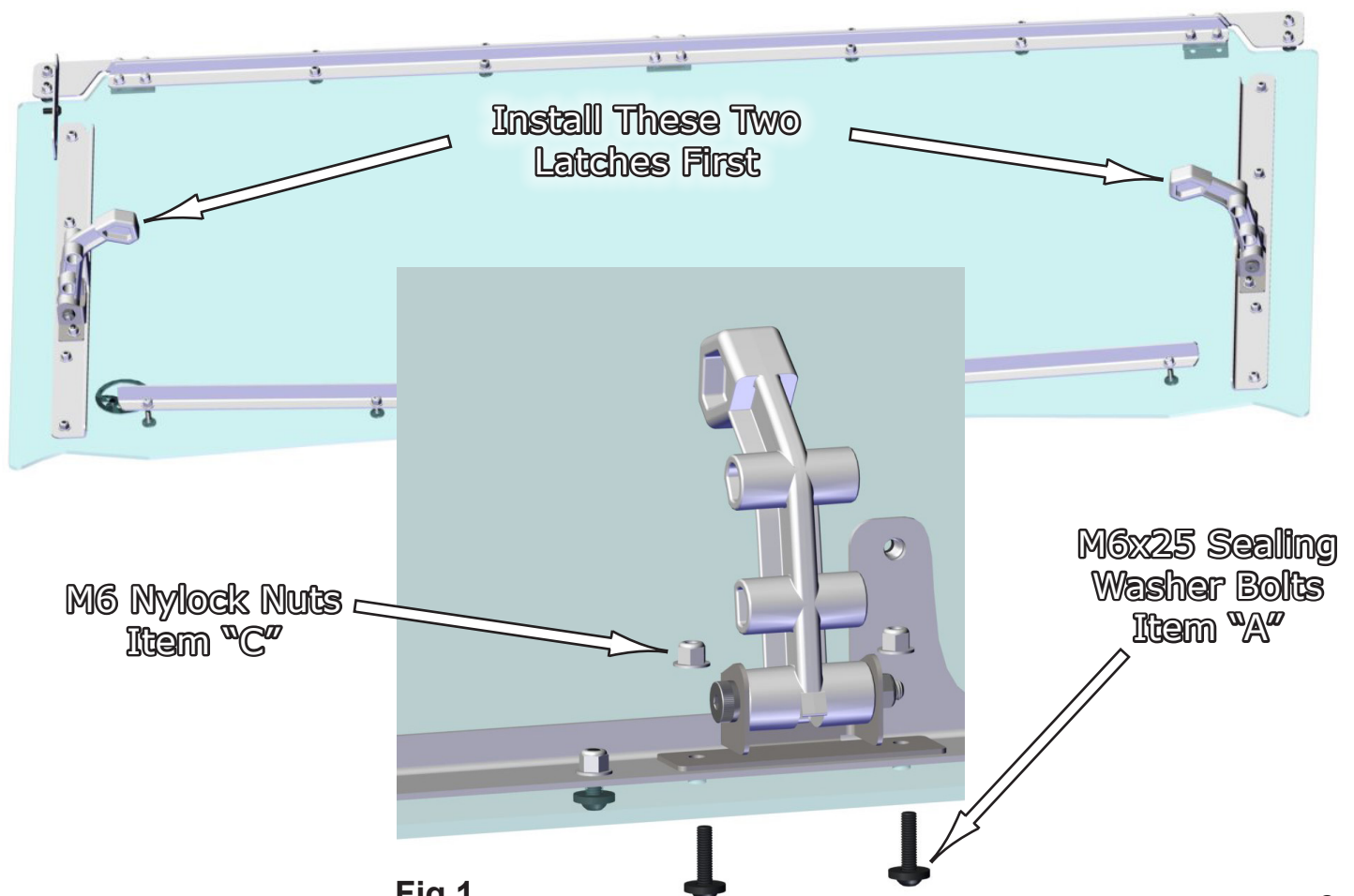

2. Next, install the Support Bracket-3 from your kit. It will be a little curved so the windshield conforms to it. You will install it using the M6x20 Seal Washer Bolt, **Item "D"** and M6 Nylock Nuts, **Item "C"** also provided in your kit. See **Fig.2**.

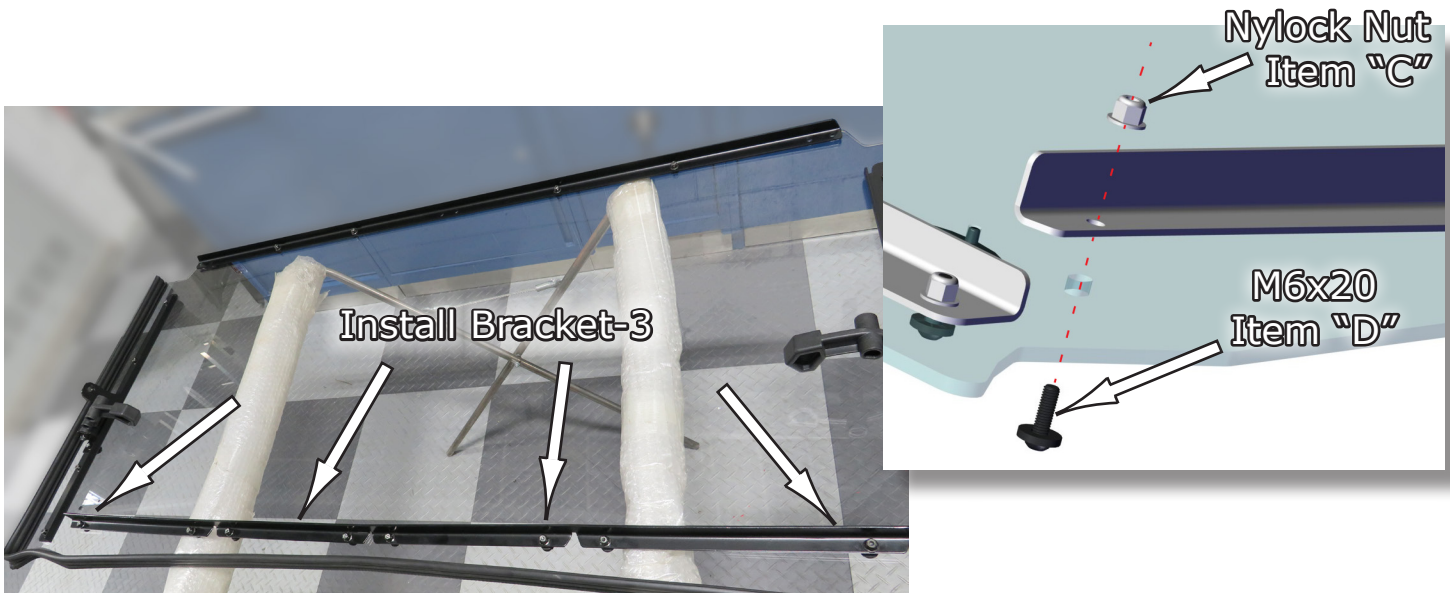

Fig.2

3. After the bracket is installed, now you can install the **Rubber Bulb Seal** all along the 3 sides of the windshield and cut to fit if needed. See **Fig.3**.

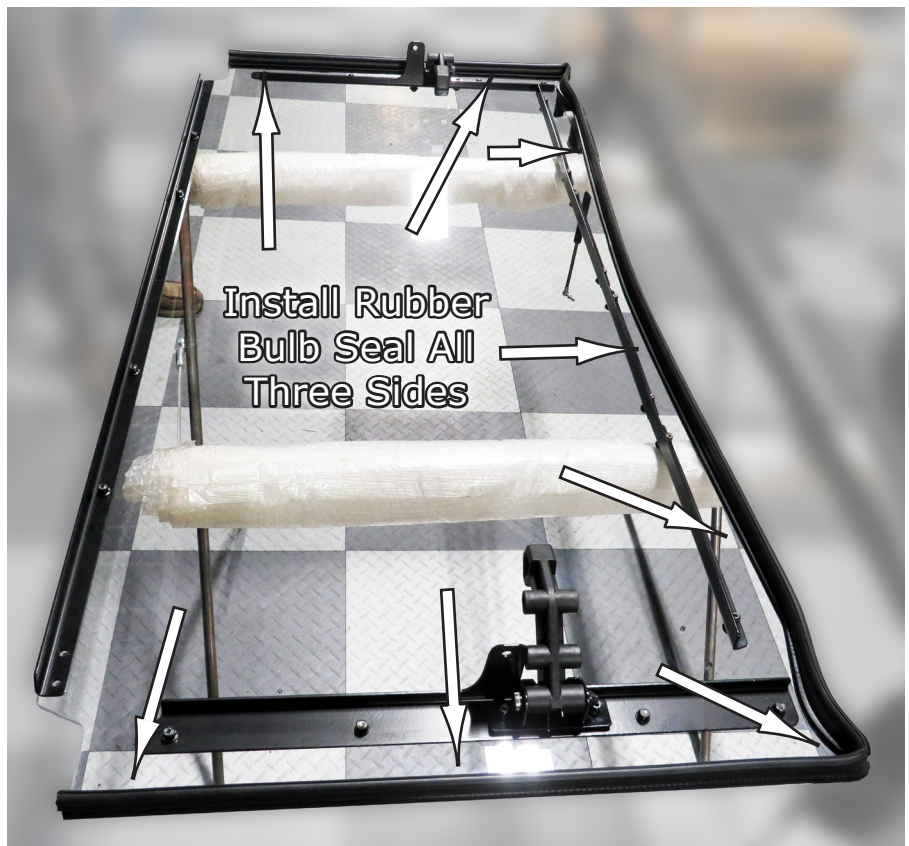

Fig.3



4. Now install both of the Strut Mount Assemblies included in your kit to the Upper Windshield section. You will attach them using the M6x25 Seal Washer Bolts, **Item "B"** and the M6 Nylock Nuts, **Item "C"** also provided in your kit. See **Fig.4**.

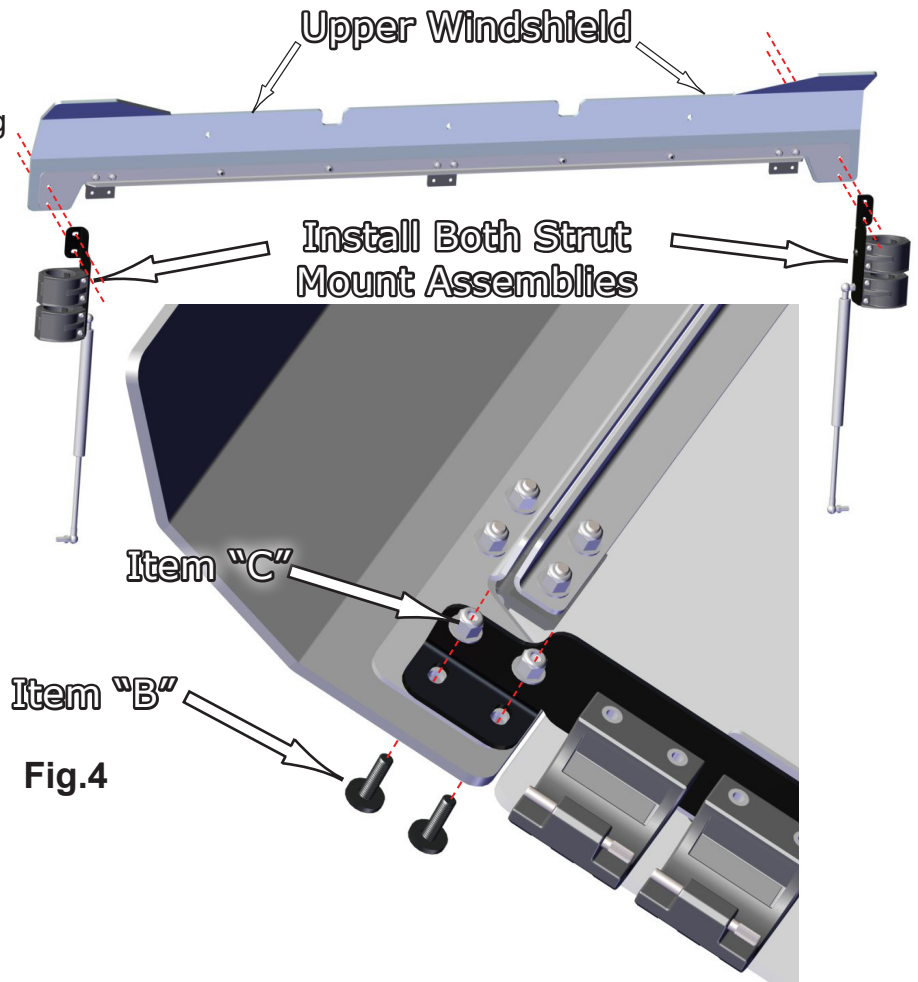

Fig.4

5. After the Strut Mounts are installed, now install the Rubber Bulb Seal along the top edge of the Upper Windshield as shown in **Fig.5**.

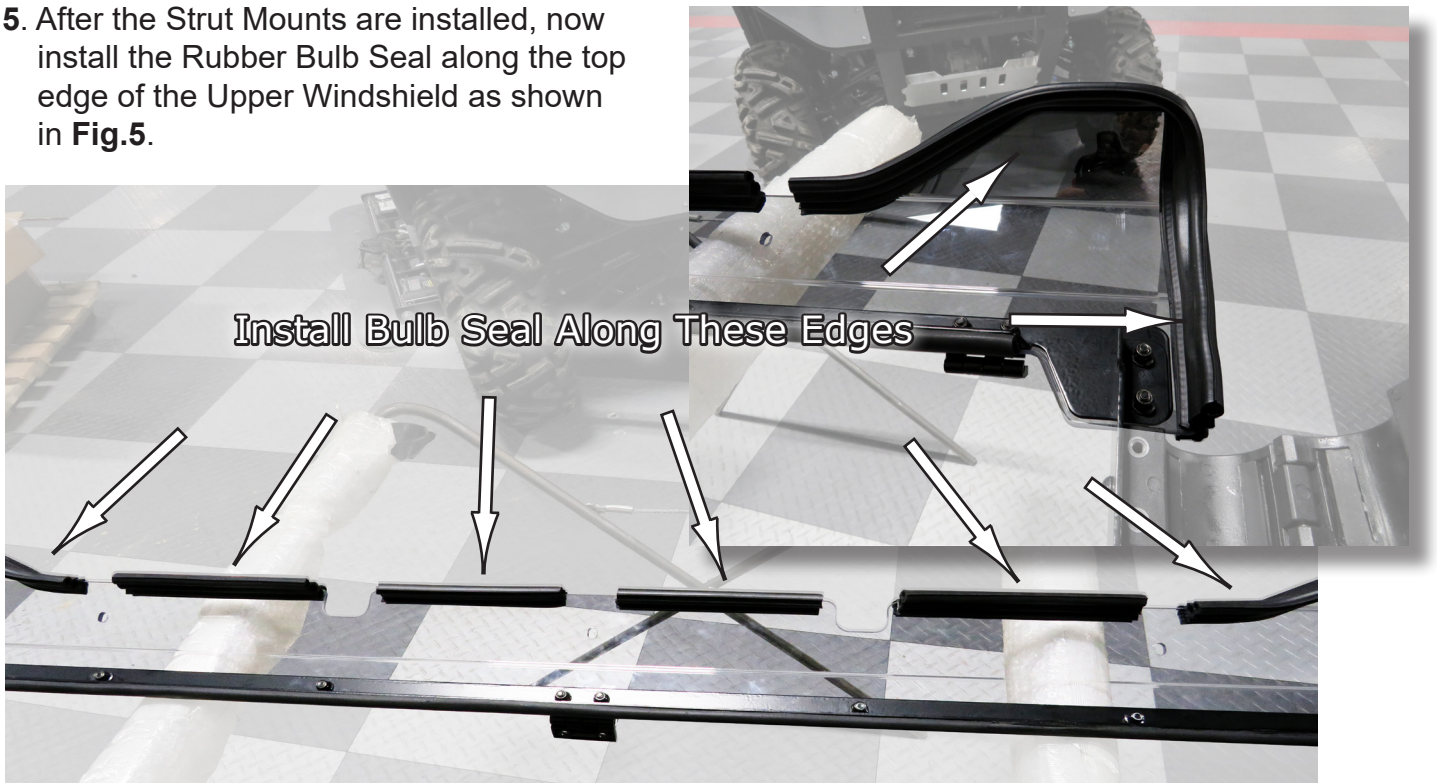

Fig.5

6. Once the Bulb Seal is installed, now install the “D” Shaped Rubber Seal along the lower frame of the upper windshield. This is an Adhesive seal, so remember to peel the backing off before applying. See Fig.6.

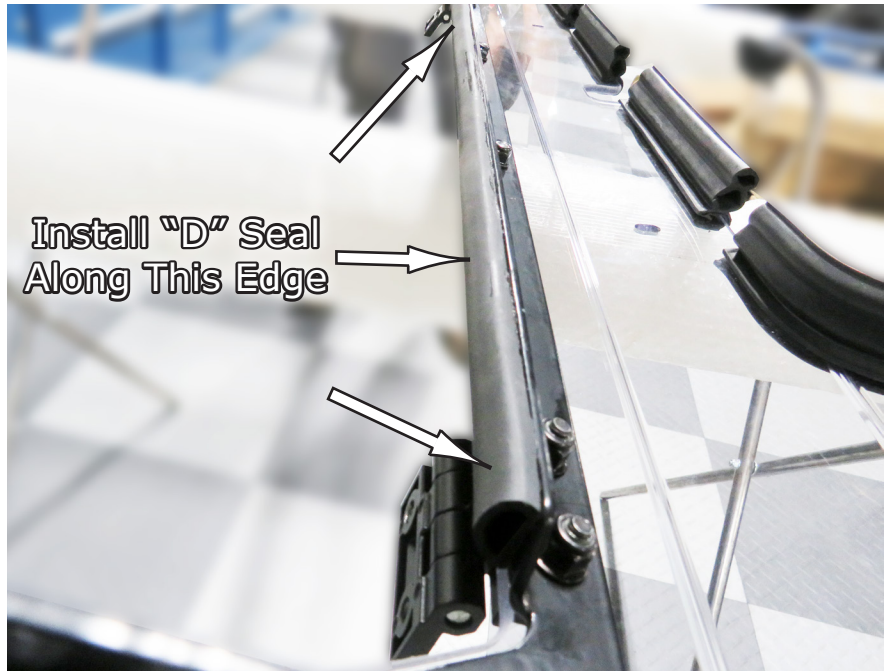
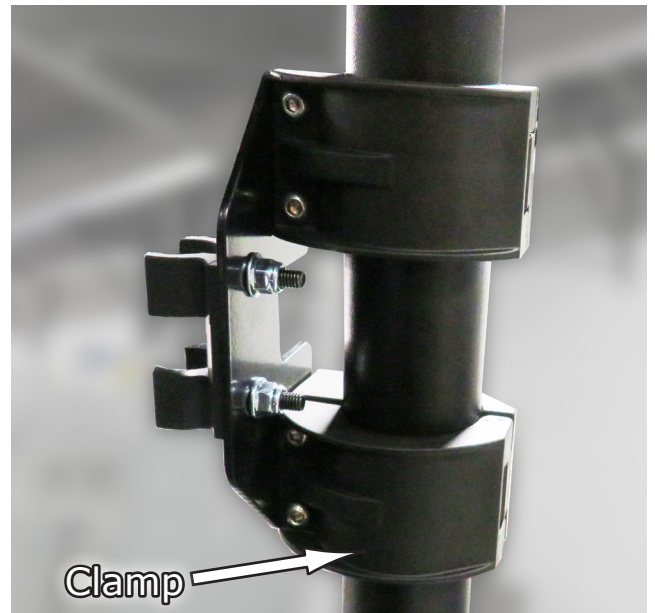

Fig.6

7. Now you will need to install the “Lower Universal Clamps” to the side vertical frame bars as the windshield has the “Upper Clamps” already installed previously. You will use the bolts already in the clamps to install around the side frame bars. Leave a little loose for adjustment later. Then you will mount the **Latch Lock Mount Bracket** to the clamps using the M8x16 Button FT Bolts, **Item”F”**.



After the bracket is mounted you can install the **Latch Block Mount** to the bracket using the M6x20 Button Head Bolts from the Latch Kit as shown in Fig.7.

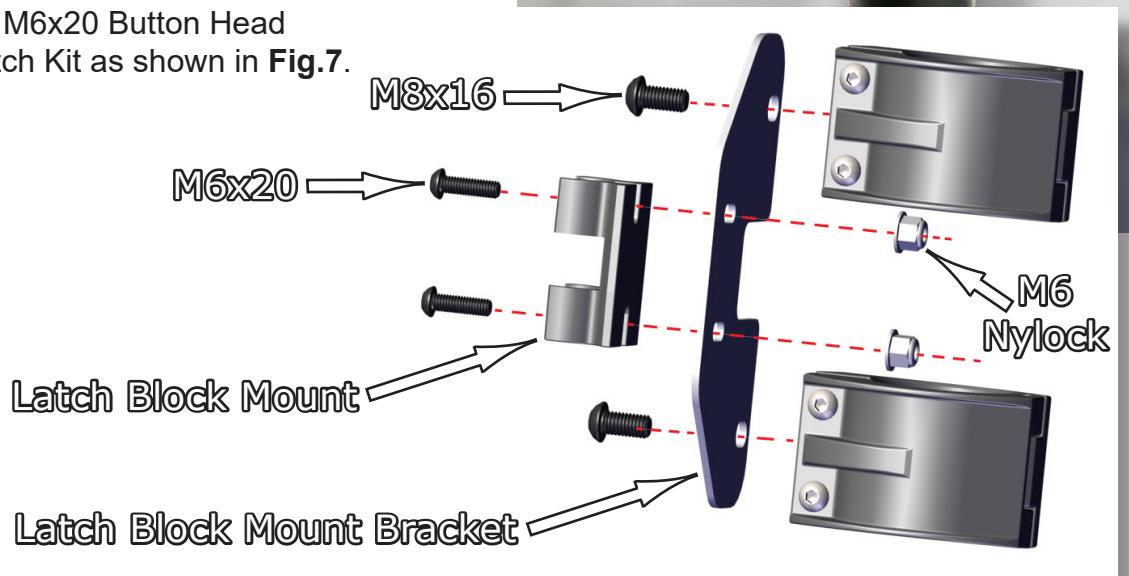

Fig.7

8. Next, install the three Tube Clamps, **Item "G"** on the top cross bar as shown in **Fig.8**, and let them hang there for now as you will align them up to the holes in the Upper Windshield panel in the next steps. **Fig.8** also shows where the clamps attach to the Upper Windshield Panel.

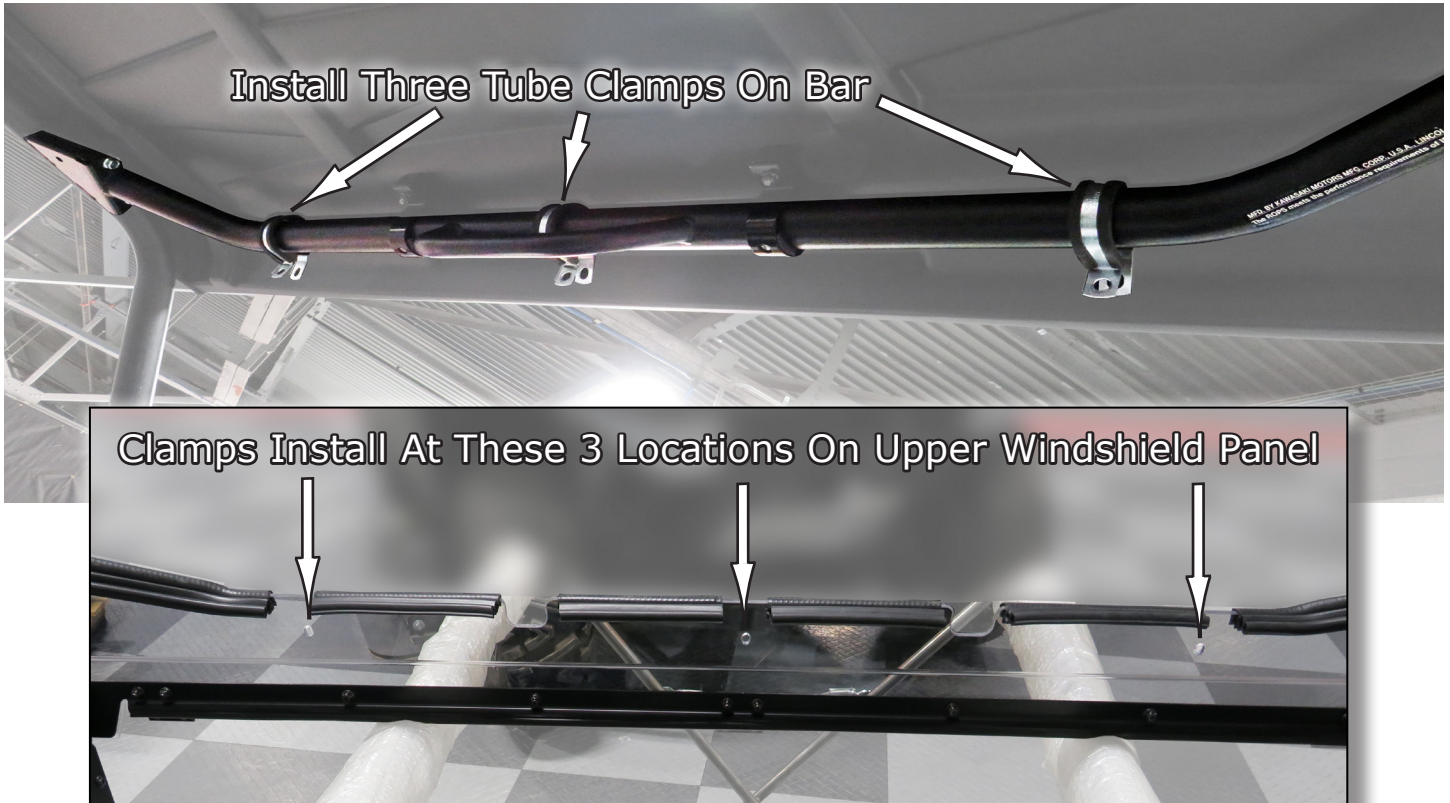

Fig.8

9. Now, to make the installation of the Upper Windshield Panel easier, you will need to remove the bolt and nut from the roof right above the cross bar where it bolts to the side frame. There is one on each side. You will reinstall after the Upper Windshield Panel is installed. See **Fig.9**.

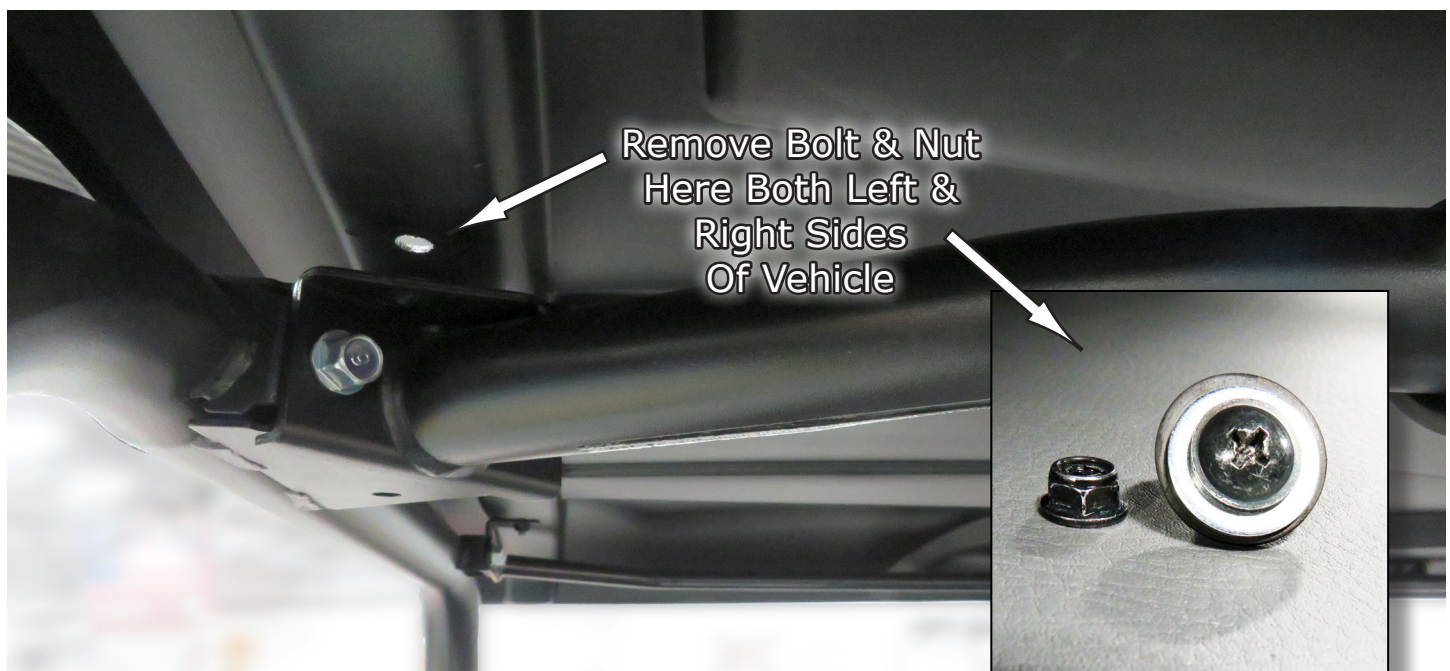

Fig.9

10. After the bolts have been removed, take the Upper Windshield Panel and slip it up under the front part of the roof. Lift the roof line up to gain access, then fit it into position as shown in **Fig.10-11**. Look at both sides to be sure it is centered with the vehicle as good as possible and make sure the seal is seated onto the frame.



Fig.10



Fig.11



11. After the the panel is in position under the roof, now attach the clamps with the gas cylinders on them to the vertical frame bars of the vehicle. They attach just like the lower ones you installed earlier. See **Fig.12**.



Fig.12

12. Now you are ready to install the Upper Windshield to the Tube Clamps you installed previously.

You will install these using the M6x25 Seal Washer Bolts, **Item "A"** and the M6 Nylock Nuts, **Item "C"**. See Fig.13.



Fig.13

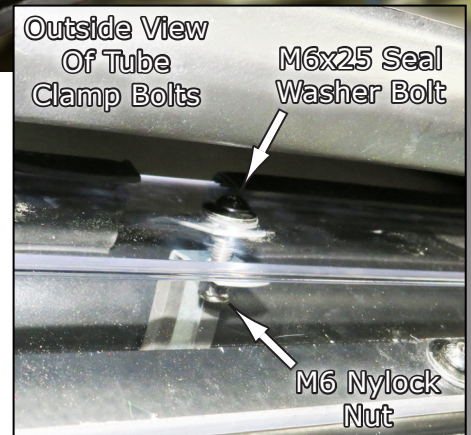

13. Next, set the main windshield on the front frame and align the holes in the windshield with the hinge holes on the Upper Windshield you just put in. Thread all 6 bolts from all 3 hinges first to make sure they all go in ok before tightening them down in place. You will use the M6x25 Flat Head Bolts, **Item "B"** and M6 Nylock Nuts, **Item "C"** in your kit. Fig.14 shows installing them.



Fig.14

14. Once the three hinges are attached to the main windshield and bolts tightened, now look at the side Window Latches. Pull the windshield tight and see if you can lock the latch into position or not. If not, you can loosen the clamps to adjust so the Latch fits correctly into the Latch Block Mount. You will need to do both sides. Once they are both working correctly, then tighten clamps and any other items loosened for adjustment back down. See Fig.15.

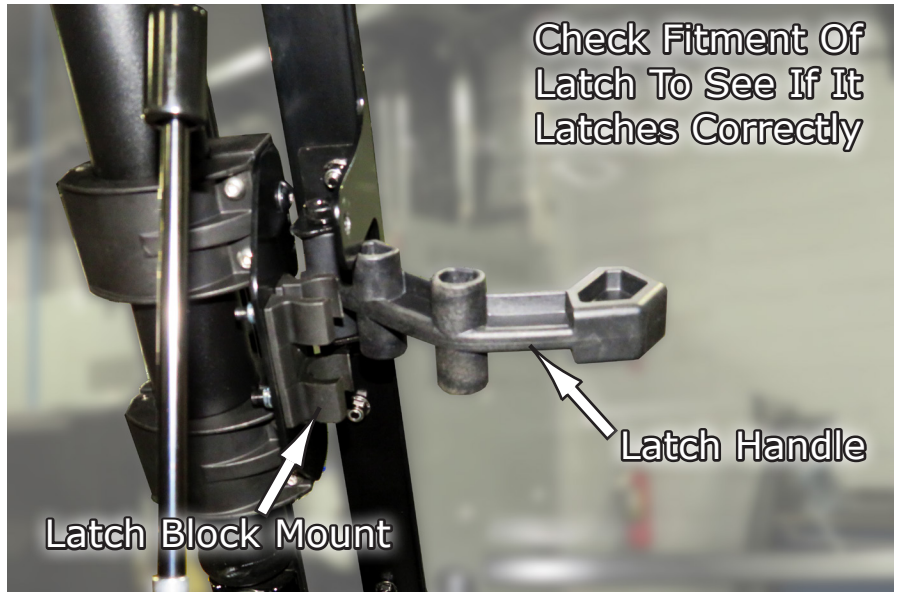

Fig.15

15. After the latches are working correctly, now go back and tighten any roof bolts that may have been loosened to help align things together. Make sure at this point they are all tight and snug. See Fig.16.



Fig.16

16. Next, you can install the gas cylinders to the main windshield. You will use the units existing lock nut as shown in Fig.17.



Fig.17

17. The last thing you need to do is reinstall the two roof bolts you removed previously before you installed the Upper Windshield Panel. There was one per side, right and left and secure. See Fig.18.



Fig.18

Liability Statement

SuperATV's® products are designed to best fit user's ATV/UTV under stock conditions. Adding, modifying, or fabricating any factory or aftermarket parts will void any warranty provided by SuperATV® and is not recommended. SuperATV's® products could interfere with other aftermarket accessories. If user has aftermarket products on machine, contact SuperATV® to verify that they will work together.

Although SuperATV® has thousands of satisfied customers, user should be aware that installing lift kits, long travel, or suspension kits, tires, etc. will change the ride of machine and may increase maintenance and part wear. Operating any off-road machine while, or after, consuming alcohol and/or drugs increases risk of bodily harm or death. No warranty or representation is made as to this product's ability to protect user from severe injury or death. SuperATV® urges operators and occupants to wear a helmet and appropriate riding gear at all times.

By purchasing and installing SuperATV® products, user agrees that should damages occur, SuperATV® will not be held responsible for loss of time, use, labor fees, replacement parts, or freight charges. SuperATV®, nor any 3rd party, will not be held responsible for any direct, indirect, incidental, special, or consequential damages that result from any product purchased from SuperATV®. The total liability of seller to user for all damages, losses, and causes of action, if any, shall not exceed the total purchase price paid for the product that gave rise to the claim.

SuperATV® will warranty only parts provided by SuperATV®. Any damage or problems with OEM housings, bearings, seals, or other manufacturers' products will not be covered by SuperATV®. SuperATV® parts and products are not warrantied if item was not installed properly, misused, or modified.

Installing, adding, modifying, or fabricating any factory or aftermarket product to your ATV/UTV may violate certain local, state, and federal laws. Be advised that laws vary depending on town, city, county, state, etc. Use of certain products on public streets, roads, or highways may be in violation law. The Buyer is solely and exclusively legally and personally responsible for any violation of the law by the installation or use of the product. You must abide by all local, state, and federal laws, including but not limited to vehicle safety, traffic laws, and ordinances. It is your responsibility to know the laws and how they apply to you.

The Buyer is responsible to fully understand the capability and limitations of his/her vehicle according to manufacturer specifications, warnings and instructions and agrees to hold SuperATV® harmless from any damage resulting from failure to adhere to such specifications, warnings and/ or instructions. The Buyer is also responsible to obey all applicable federal, state, and local laws and ordinances when operating his/her vehicle while using this product, and the Buyer agrees to hold SuperATV® harmless from any violation thereof.

If you have any problems/questions on this kit, contact us by email at Superatv.com.

Need help with your installation?



sales@superatv.com



www.superatv.com



1-855-743-3427



8:00am - 9:00pm EST M-Th
8:00am - 7:00pm EST Friday
9:00am - 2:00pm EST Saturday

*Thank You
For Choosing*



Like SuperATV on Facebook to keep up to date on new products!