

INSTALLATION INSTRUCTIONS

**Soft Cabin Enclosure: SE-H-PIO1K6-001
(4) Seater**

- Please look through and read these instructions BEFORE starting so you understand what processes you'll be doing, and possible extra tools you may need.
- Do Not discard product packaging until installation is complete and functioning properly.



Snaps (32pcs)
(snap not to scale)

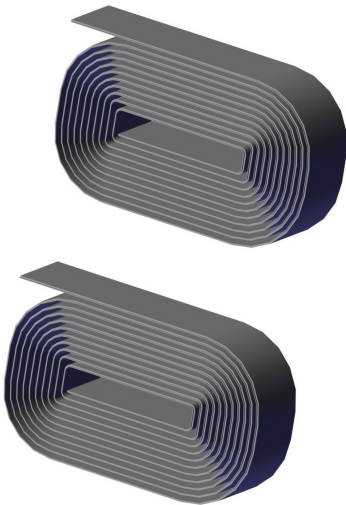
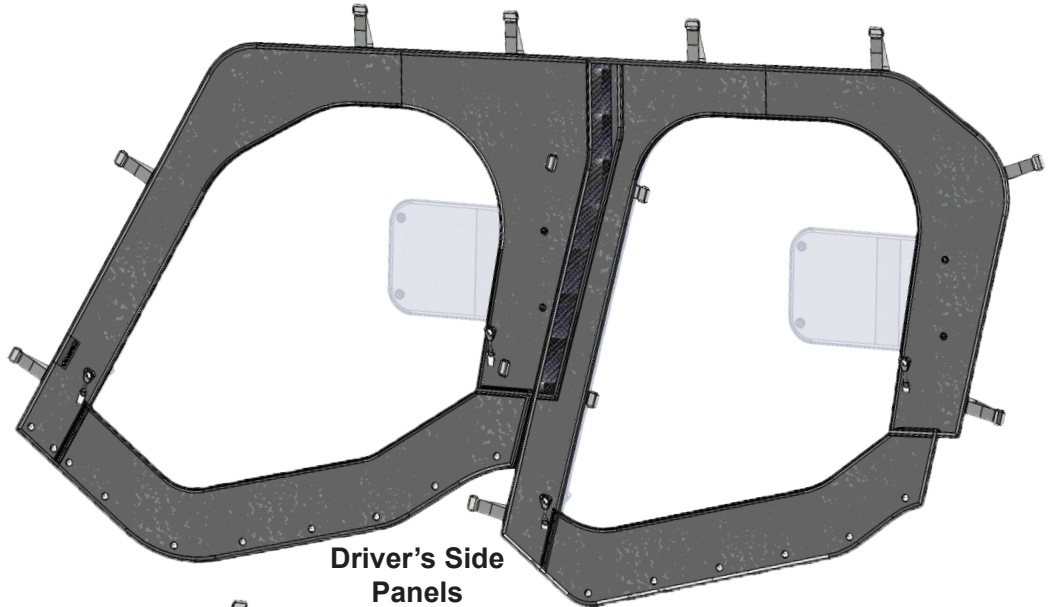

**Hook & Loop
(2 Rolls)**

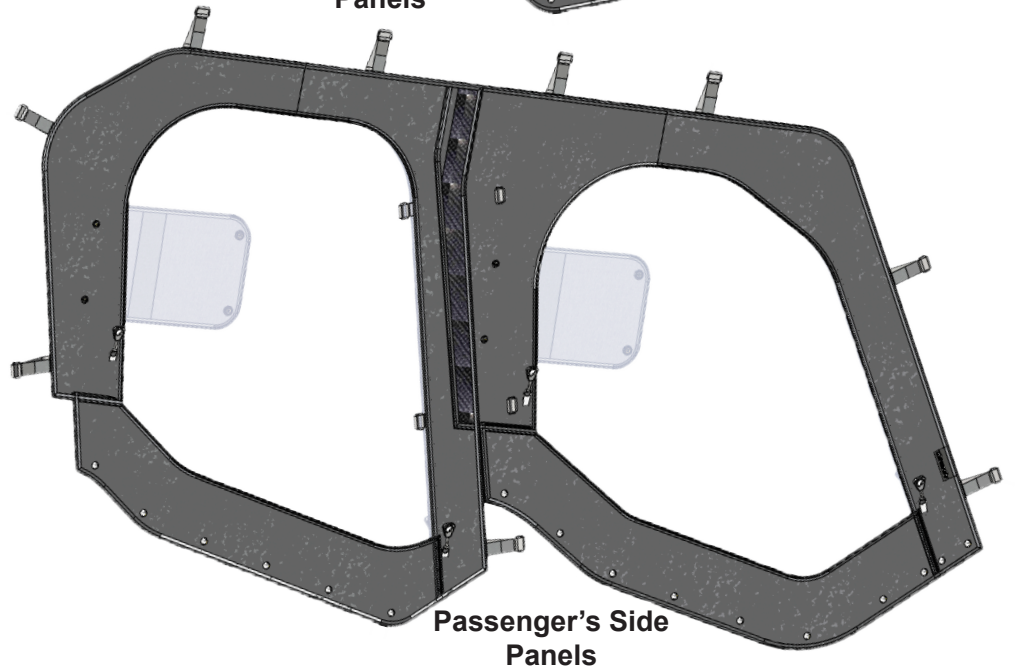

... What You'll Be Doing ...

- 🌀 Installing Hook & Loop to the Framing.
- 🌀 Securing Window Straps to Framing.
- 🌀 Installing Hook & Loop To Door Panels
- 🌀 Installing Snaps to Door Panels (if desired)
- 🌀 Repeating the same for each side and for both Front and Back

... Shop Tips ...

- Windows must be completely open when closing or opening Doors.
- Hook and Loop Fasteners should be applied at a temperature of 70°F or above.
- Use Denatured Alcohol and thoroughly clean any area where Hook and Loop Fasteners will be installed.
- Installing and adjusting Soft Cab is easier with two people.
- When cleaning Soft Cab, use soap and water only. Do not use detergent, window cleaner, solvents.
- Do not use a dry cloth or rag on windows.
- Do not fold Soft Cab before storing. Zip windows closed and roll Soft Cab to store.
- Do not discard packaging until product has been successfully installed.
- Doors may be secured with Snaps only, Hook and Loop Fastener only, or a combination of Snaps and Hook and Loop Fastener.
- Any whiteness, clouding, wrinkles, or waves that develop will gradually disappear when Soft Cab is exposed to sunlight and/or heat. Use a heat gun or hair dryer to speed up this process. Do not overheat or heat in one area for an extended period of time.
- Windows must be rolled up when trailering machine.

... Front Doors Installation ...

1. First, cut the Hook & Loop to fit the locations on the frame cage. Then peel off backing and apply to those areas where the windows will be fitting to. See **Fig.1**.

Repeat for opposite side.



Fig.1

2. Next, place Soft Cab onto machine and loosely secure the Straps to the Frame Cage. There are (6) of them to attach. See **Fig.2 and 3.**

3. After you align the Soft Cab to the machine in the desired position, then cinch the Straps tight to the Frame Cage.

4. Then secure all Flaps to the Hook and Loop fasteners, and repeat for the opposite side.

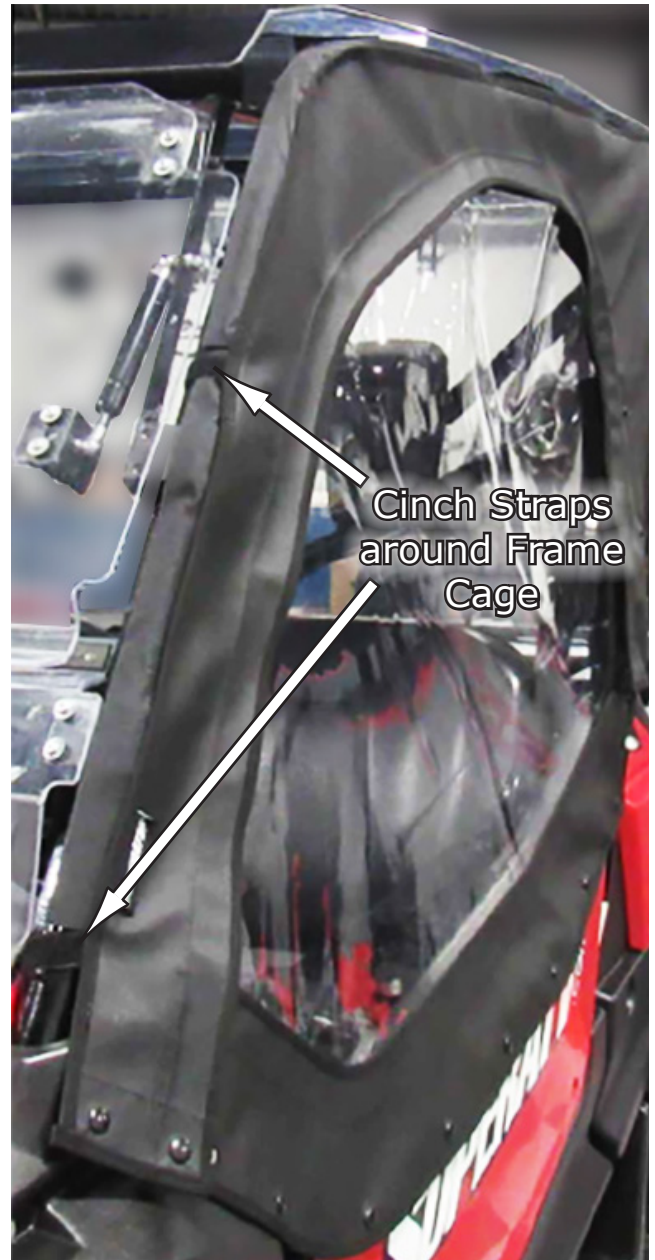

Fig.2

(6) Straps on Front Door Panels



Fig.3

The next process is, how do you want to attach the lower flaps to the doors. There are a few combinations you can choose from. One is just using “Hook & Loop”, then next is to use the provided “Snaps”, and the third is the combination of them both. We’ll first go over the just the Hook & Loop installation if you choose to use this method.

... Hook and Loop Installation Only ...
(These steps must be done for Each Instance)

5. First, cut and fit the Hook & Loop to fit the bottom edge of the Flap of the panel. Then, with the window panel in place and fixed to the machine, apply the Hook and Loop mate onto the flap. See **Fig.4**. At this point, the Hook & Loop is together and now stuck onto the flap.
6. Now peel off the other side of the Hook & Loop adhesive backing and flap down the flap onto the door in it’s natural position and press firmly along the areas you put the Hook & Loop onto. This will stick the other half of the Hook & Loop onto the door panel.

! At This Point, Stop And Wait 15-30 mins For Adhesive To Set Up On The Door Before Trying To Separate The Hook & Loop !



Fig.4

7. After you've waited for it to set up, now carefully open and separate the flap using one hand to lift and separate it as shown in **Fig.5**.

Repeat for opposite side.

NOTE: If adhesive starts to lift off the door in some places, after separating the Hook & Loop, you can apply heat to warm the side that is on the door to help make it stick, if need be. A Hair Dryer or similar will work. Do Not over heat. Do this gradually. See **Fig.5**.



Fig.5

... Snaps Installation Only ...

8. First, you will need to mark the locations of the snaps so you can install them into your door panel.

To do this, on the snap itself, mark the bottom surface perimeter of each snap with a Paint Marker, Lip Stick or other Marker so you can transfer the location of the snap onto the door panel more accurately.

Once you have outlined the snap, flap down the flap in it's natural position and press firmly to the door panel to transfer the outline of the snap to the door. See **Fig.6**.



Fig.6

9. After you've marked your location of the snaps, Find the center of each outline. This is where you will install the snap. **Fig.7** shows a snap installed in the center of the outline.

After installing your snaps, snap down the top and repeat for the opposite side.



NOTE: Since the Snaps that are provided in your kit are Self Drilling and Tapping, Just find the center of your location and press while screwing them into the door. These will drill thru and seat themselves into the door. No need to pre-drill.

Fig.7

... Rear Doors Installation ...

10. Just as you did for the Front Doors, apply the Hook & Loop to the Fame Cage as shown in **Fig.8**.



Fig.8

11. Be sure to wrap the Hook & Loop over the top bar slightly so it grabs the top securely at the top. See **Fig.9**.



Fig.9

12. After applying the Hook & Loop, press the panel onto the frame and be sure to secure all of the panel wrap ties to the frame as you did with the Front doors. See **Fig.10**.



Fig.10

13. At this point as you did with the front doors, you'll decide if you're going to use just Hook & Loop to attach the panel to the doors, or the snaps, or both.

Again, you will apply the Hook & Loop over the existing snaps on the panel if just using that, and then press it down into the door, let it sit 15 mins, then separate them as before in step 5. Or if using snaps, you will mark the snaps on the underneath side of the panel with a paint marker or similar, and apply them to the door to get your center marking of the snaps, then screw the snaps into those locations, same as with the front doors previously, also in Step 5. See **Fig. 11-14**.



Fig.11



Fig.12



Fig.13



Fig.14



Fig.15

14.Once Hook & Loop have been installed, you may want to trim the excess off to the flap to clean it up, if desired. See **Fig.14-15**.

15.After trimming or finishing this side, repeat same procedures for opposite side.

Liability Statement

SuperATV's® products are designed to best fit user's ATV/UTV under stock conditions. Adding, modifying, or fabricating any factory or aftermarket parts will void any warranty provided by SuperATV® and is not recommended. SuperATV's® products could interfere with other aftermarket accessories. If user has aftermarket products on machine, contact SuperATV® to verify that they will work together.

Although SuperATV® has thousands of satisfied customers, user should be aware that installing lift kits, long travel, or suspension kits, tires, etc. will change the ride of machine and may increase maintenance and part wear. Operating any off-road machine while, or after, consuming alcohol and/or drugs increases risk of bodily harm or death. No warranty or representation is made as to this product's ability to protect user from severe injury or death. SuperATV® urges operators and occupants to wear a helmet and appropriate riding gear at all times.

By purchasing and installing SuperATV® products, user agrees that should damages occur, SuperATV® will not be held responsible for loss of time, use, labor fees, replacement parts, or freight charges. SuperATV®, nor any 3rd party, will not be held responsible for any direct, indirect, incidental, special, or consequential damages that result from any product purchased from SuperATV®. The total liability of seller to user for all damages, losses, and causes of action, if any, shall not exceed the total purchase price paid for the product that gave rise to the claim.

SuperATV® will warranty only parts provided by SuperATV®. Any damage or problems with OEM housings, bearings, seals, or other manufacturers' products will not be covered by SuperATV®. SuperATV® parts and products are not warrantied if item was not installed properly, misused, or modified.

Installing, adding, modifying, or fabricating any factory or aftermarket product to your ATV/UTV may violate certain local, state, and federal laws. Be advised that laws vary depending on town, city, county, state, etc. Use of certain products on public streets, roads, or highways may be in violation law. The Buyer is solely and exclusively legally and personally responsible for any violation of the law by the installation or use of the product. You must abide by all local, state, and federal laws, including but not limited to vehicle safety, traffic laws, and ordinances. It is your responsibility to know the laws and how they apply to you.

The Buyer is responsible to fully understand the capability and limitations of his/her vehicle according to manufacturer specifications, warnings and instructions and agrees to hold SuperATV® harmless from any damage resulting from failure to adhere to such specifications, warnings and/ or instructions. The Buyer is also responsible to obey all applicable federal, state, and local laws and ordinances when operating his/her vehicle while using this product, and the Buyer agrees to hold SuperATV® harmless from any violation thereof.

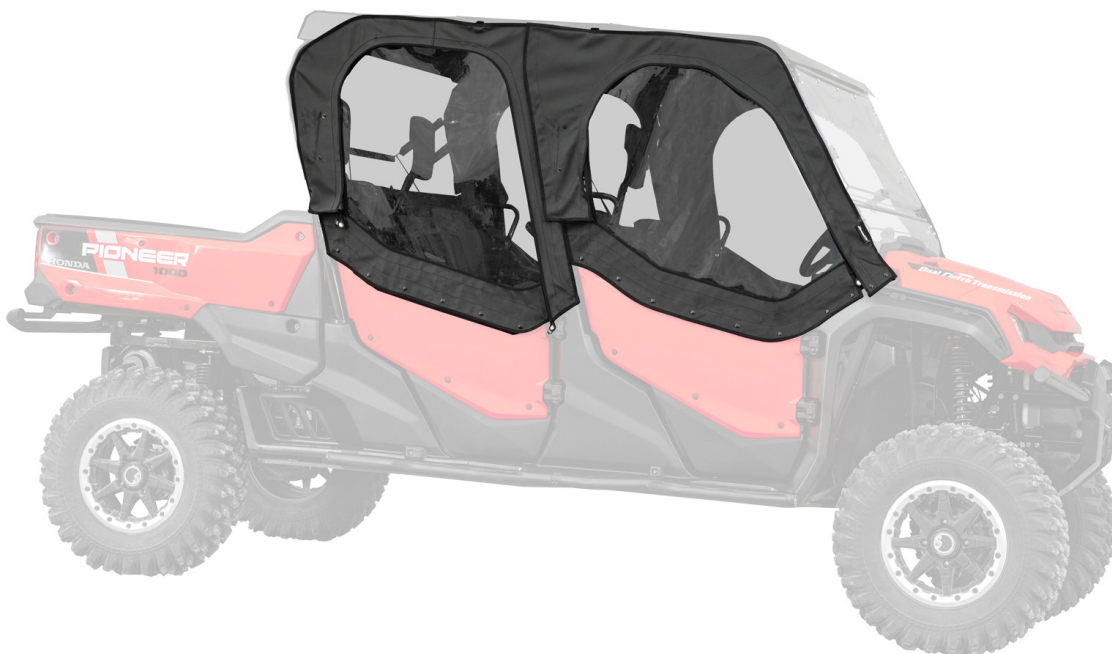

If you have any problems/questions on this kit, contact us by email at [Superatv.com](mailto:sales@superatv.com).

Need help with your installation?



sales@superatv.com



www.superatv.com



1-855-743-3427



8:00am - 9:00pm EST M-Th
8:00am - 7:00pm EST Friday
9:00am - 2:00pm EST Saturday

*Thank You
For Choosing*



Like SuperATV on Facebook to keep up to date on new products!