

# PART#: 75-5159D / 75-5159D



PRINT

## Vehicle Application

YEAR: 2021-2022

MAKE: Jeep

MODEL: Wrangler 392

ENGINE: 6.4L

### Note:

This intake kit may not fit with the following Aftermarket Parts installed:

- Body Lift or Lowering Kit
- Custom Hood
- Throttle Body Spacer / Upgrade
- Aftermarket turbocharger

## Tools Required

- 10mm Socket + Socket Wrench, Driver, or Wrench
- 5/16" Nut Driver or Socket and Driver
- 1/4" Nut Driver or Socket and Driver
- Flat Head Screwdriver
- Panel Popper
- Knife, Cutting Tool

**Note:** Approximate Install Time: 1 Hr 00 Mins.

## S&B Filter Maintenance

KF-1083 ([https://www.sbfilters.com/sb-intake-replacement-filter-40974?variant\\_id=939](https://www.sbfilters.com/sb-intake-replacement-filter-40974?variant_id=939)) Cotton Cleanable : If the enclosed filter is RED, it came pre-oiled from the factory.

Click here ([https://www.sbfilters.com/replacement-filters/filters-sb-intakes/kf-1057?variant\\_id=223](https://www.sbfilters.com/replacement-filters/filters-sb-intakes/kf-1057?variant_id=223)) for exact oil amount required for cleaning.

KF-1083D ([https://www.sbfilters.com/sb-intake-replacement-filter-40974?variant\\_id=940](https://www.sbfilters.com/sb-intake-replacement-filter-40974?variant_id=940)) Dry Extendable : If the enclosed filters is WHITE, it is a disposable filter and should be discarded once it reaches capacity. This filter does not require oil.

## **Before You Start**

- Please read the entire product guide before proceeding.
- Ensure all parts are present.
- If you are missing any of the components, call our customer support at (909) 947-0015.
- Do not work on your vehicle while the engine is hot.
- Make sure the engine is turned off and the vehicle is in Park or the Parking Brake is set.

## **Related Products**

- Cotton Cleanable Filter (  
KF-1083 ([https://www.sbfilters.com/sb-intake-replacement-filter-40974?variant\\_id=939](https://www.sbfilters.com/sb-intake-replacement-filter-40974?variant_id=939)))
- Dry Extendable Filter (  
KF-1083DD ([https://www.sbfilters.com/sb-intake-replacement-filter-40974?variant\\_id=940](https://www.sbfilters.com/sb-intake-replacement-filter-40974?variant_id=940)))
- Cleaning & Oiling Kit (88-0008 (<https://www.sbfilters.com/cleaning-kits/precision-ii-cleaning-oil-kit>))

## **Operation in Snow and Rain**

If you are driving in heavy snowfall or extreme rain conditions, you should always check for accumulated snow and water on the air filter following your OE recommendations for driving in these conditions. The following is recommended after operating the vehicle up to 100 miles in

heavy snowfall or extreme rain: At the earliest opportunity, open the hood and check the airbox and filter. If any snow has accumulated, make sure to remove the snow from the filter, box, and inlet. It is okay if the filter is a little wet. Wet filters will normally dry out on their own. If the filter is dripping wet, it should be replaced with another filter that is not wet. Do not reuse the dripping wet filter until it has naturally dried.

## **Air Box Plug Testing**

Stock intake boxes are a significant contributor to poor airflow which is why S&B designs custom air boxes with secondary and/or enlarged openings. With that said, S&B recognizes the benefits of cooler air, so we have included a plug to seal off the opening if so desired. For optimal performance, we recommend that the intake be used without the end cap except in conditions of extreme heatwave.

## **Performance Testing**

- After your installation is complete engage parking brake and start your engine. Listen for abnormal noises. If an air leak is detected, re-inspect hoses and connections as they may need to be repositioned and tightened
- S&B FILTERS recommends that you keep your OE intake system in the event it is required in the future.
- In order to maintain your warranty, all connections and components must be checked periodically for alignment and for proper tension on all connections. Failure to do so may void your warranty.
- Use only S&B FILTERS cleaning and oil products to service your filter. Using any other brand oil and or cleaners on your S&B air filter may void your warranty.

## **Warning!**

If your vehicle has a Vehicle Emission Control Information decal affixed to the factory airbox, a new replacement label must be obtained and installed in a readily visible position in the engine compartment in order to remain CARB compliant. Failure to do so will prevent the vehicle from passing a smog check. Replacement labels can be ordered from your local dealership.

Regulations state that the VECI label shall not be affixed to any equipment which is easily detached from the vehicle. Label placement, under the hood on a painted surface is recommended.

## **Emission Standard**

The California Air Resource Board (CARB) requires that an E.O. identification label be applied to the vehicle in order to pass a smog check inspection when a Performance Intake Kit has been installed. You must place the E.O. label provided on or near the intake kit after installation so that a smog check technician can easily verify the E.O. number. Check the status of the exemption process by looking up a specific part number at [www.sbfilters.com](http://www.sbfilters.com). The CARB Exemption number and/or status is listed under the Product Details section for each part number. If the status shows as "Pending," CARB has yet to issue an exemption. Products that have not been issued an EO number are street legal in most states, but may not be used on emission controlled vehicles in the state of California and are for off-road use only. If you purchased your kit from S&B Filters directly, we will automatically mail you your Exemption Sticker when it is issued to us. If you purchased your kit from an authorized S&B Filters Dealer, log onto our web site and register to receive your Exemption Sticker.

## **PARTS LIST**

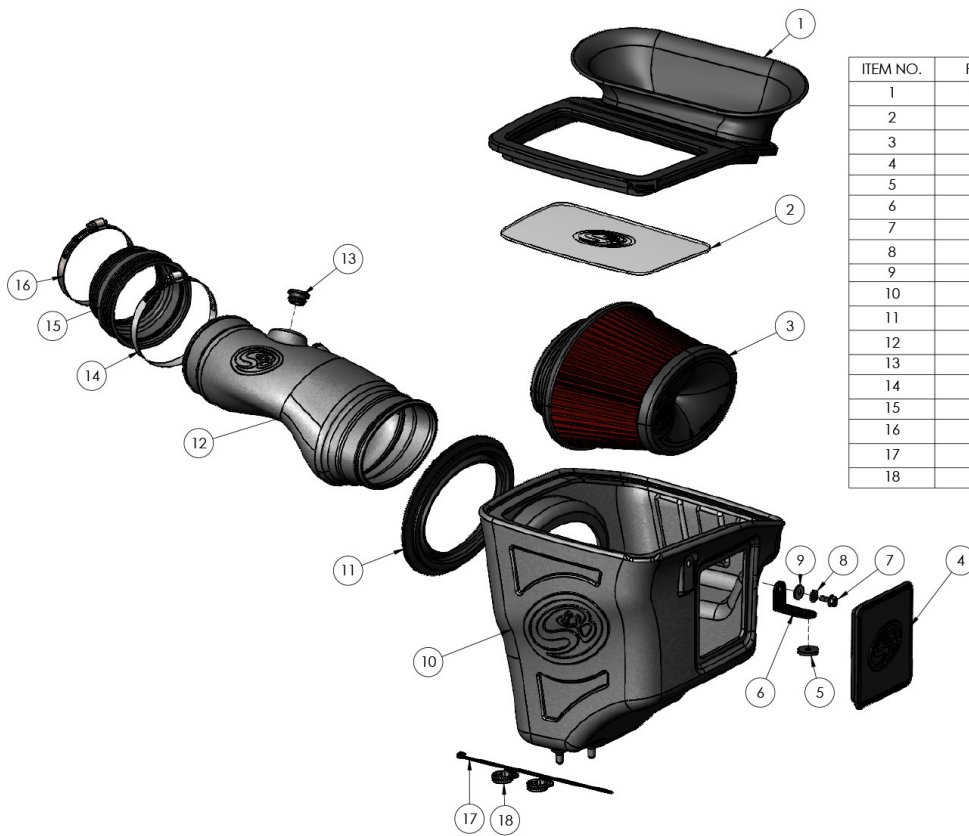

ITEM NO.	PART NUMBER	DESCRIPTION	QTY.
1	AI2650C-00	Snap-In Lid Assembly, Silicone	1
2	AI2651-00	Clear Lid	1
3	KF-1083	S&B Filter	1
4	AI1892C-00	Box Plug, Silicone	1
5	AI1765-00	Rubber Washer, Black	1
6	AI1062-00	Angle Bracket, Black	1
7	AI2014-00	M6 x 16mm Hex Flange, Zinc Yellow	1
8	AI1309-00	Lock Washer, M6	1
9	AI1535-00	Flat Washer, M6	1
10	AL1394B-00	Air Box	1
11	AI1689C-00	Tube Seal, Silicone	1
12	AL1394-00	Intake Tube	1
13	AI1948C-00	IAT Sensor Adapter, Silicone	1
14	AG1018-00	Hose Clamp, #64	1
15	AI1665C-00	Silicone Step Coupler, Silicone	1
16	AG1019-00	Hose Clamp, #56	1
17	AI1750-00	Cable Tie, 9" Long	1
18	AG1000-00	Hose Clamp, #8	2

# INSTALLATION STEPS



## **STEP 1**

With the engine turned off and cooled down, unscrew the bolt securing the stock airbox on the driver's side with a 10mm socket or wrench. Set the bolt aside it will be reused later to install the S&B airbox.



## **STEP 2**

Unscrew the hose clamp on the stock intake tube using a 5/16" wrench or flat head screwdriver.



### **STEP 3**

Remove the plastic clips securing the wiring harness using a flat head screwdriver or panel popper.





## **STEP 4**

On the stock tube unclip the IAT sensor harness from the stock sensor.



## **STEP 5**

The engine cover is held in place by 2 rubber grommets, firmly lift up on the cover to pop it out of place.



## **STEP 6**

Remove CCV hose from airbox and engine (Some models may have clips securing CCV hose, just use pliers to squeeze them and slide them down the hose)



## **STEP 7**

Pull stock tube off throttle body and firmly pull airbox out of the vehicle.



## **STEP 8**

Install silicone tube seal, box plug, and IAT grommet on S&B airbox and tube.



## **STEP 9**

First, place S&B filter in airbox and make sure hose clamp is loose, then push tube through tube seal and directly into filter, tighten hose clamp with 5/16" wrench or flat head screwdriver.



## **STEP 10**

Slide silicone coupler and hose clamps onto S&B tube.



## **STEP 11**

First, make sure all 3 rubber grommets did not get pulled off from removing the stock airbox previously. Slide S&B coupler onto throttle body first at a downward angle, then push airbox straight down into stock rubber grommets.





## **STEP 12**

First, install the short side of the angle bracket onto S&B airbox with bolt, washer, and lock nut. Place rubber washer underneath the bracket against the painted side to protect from scratches and reinstall stock bolt into the fender using 10mm socket or wrench.



## **STEP 13**

Tighten both clamps on the throttle body and S&B tube using a 5/16" wrench or flat head screwdriver.



## **STEP 14**

Slide the CCV hose back onto the engine first and then line up the hose with the nipple on the S&B tube. Use a knife or scissors to cut 2-3 inches off the stock CCV hose so that it slides all the way over the nipple on the tube without the hose collapsing in on itself.



## **STEP 15**

Slide both hose clamps onto CCV hose and tighten using ¼" wrench or flat head screwdriver onto S&B tube and engine.

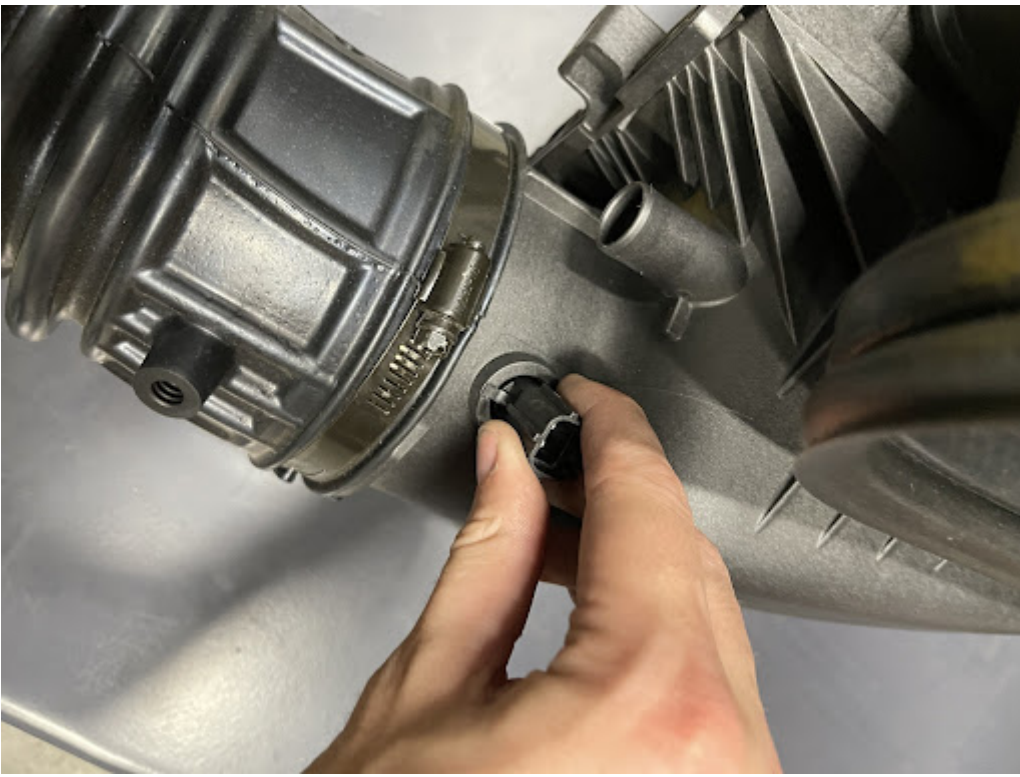

## **STEP 16**

Transfer the IAT sensor from the OEM tube into the S&B tube as shown. The locking tab should rotate over the ramp and lock into position, use the turn arrow for indication.



## **STEP 17**

Reconnect IAT wire harness onto sensor, it should clip into place, zip tie harness to reduce slack.



## **STEP 18**

Remove the protective wrapping off the polycarbonate lid. Install the snap-in silicone lid seal around the polycarbonate lid. Slide S&B snap-in lid to backside of airbox first and then apply pressure around the perimeter to lock it into place.



## **STEP 19**

Inspect your installation. Make sure the kit is properly positioned and all fasteners and hose clamps are secured. Keep all stock parts in the event you would ever need to reinstall the stock intake assembly. If you are an installer, give the owner the QR code for the Installation Instructions so that he/she is aware of the Maintenance and Operation procedures. The installation is now complete.