



Gator Fasteners Performance Head Stud Kit

Fits: Dodge 1989-1998 5.9L Cummins Diesel • Part Number: HSK5912

Parts Included:

- (26) Head Studs
- (26) Head Stud Nuts
- (26) Head Stud Washers
- (6) Head Bolts
- (1) Assembly Lube

Tools Needed:

- Socket Set
- Torque Wrench
- Thread Chaser
 - M8 x 1.25 (item # TCCM8x1.25)
 - M12 x 1.75 (item # TCCM12x1.75)

Please Read Instructions before starting installation. If you don't feel confident that you can complete this task, do not start it and seek professional help!

Note: The Head Stud Kit requires modification of the rocker arm pedestal to accommodate a shorter rocker arm pedestal head stud included in this kit. This is to bring the Head Stud Nut and Washer combination down to the same installed height as the factory head bolt

- These instructions only cover the installation and torque sequence/technique of the Head Stud Kit.
- Clean and inspect the Studs, Washers, and Nuts to ensure they are free of shipping damage and obvious defects.
- Clean all threads in the block. It is recommended to use a Thread Chaser on the threads of the block so that they are completely clean to ensure proper thread engagement and accurate torque reading.
- Lubricate the threads of the Head Studs and install them into the block. Be sure to only screw them in **HAND TIGHT**. Look across the tops of the head studs to see that they all appear to be the same length. If one is taller, remove the stud, clean the threads in the block and re-install.
- Install the head gaskets and cylinder heads; check for any misalignment.
- Install push rods and ensure they are fully seated into the tappets.
- Install Modified/Milled Rocker Arm Assembly (use either part number MRAP5912 or have your stock pedestals machined to the specs listed below) with adjusters backed off.
- Place head stud washers onto the head studs. Then lubricate the top of head stud washers and head stud threads with assembly lube.
- Lubricate the Rocker Arm Pedestal Bolt threads and install them into the pedestal **HAND TIGHT**.
- Lubricate the mating face and threads of the Head Stud Nuts with Assembly Lube and install them **HAND TIGHT**.

- ❑ Snug all Head Stud Nuts & the 8mm Rocker Arm Pedestal Bolts, then follow the torque sequence below in a 3-step process for the Head Stud Nuts. **The Rocker Arm Bolts will NOT be torqued until a later step.**
 1. The first round should be to 45 ft lbs.
 2. Then repeat the sequence for 90 ft lbs.
 3. Followed by 125 ft lbs.

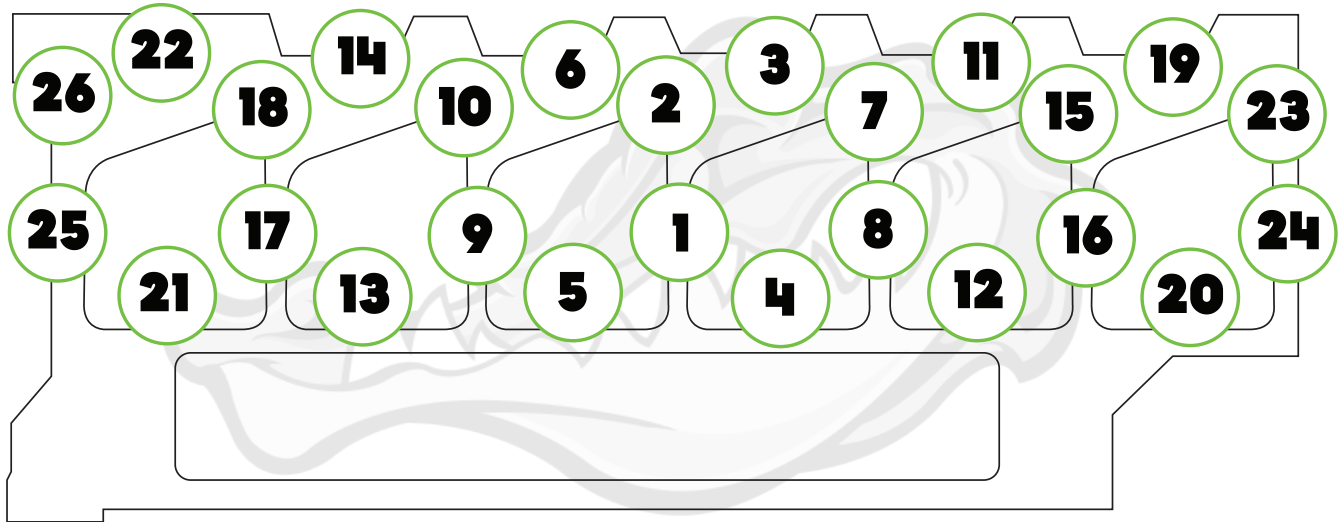

- The amount of Head Stud threads showing above the Head Stud Nut should all be about the same. If one appears to have more thread, the stud is most likely not all the way in the head.

- ❑ Once the Head Studs Nuts are torqued, torque the Rocker Arm Pedestal Bolts to 25 ft lbs.

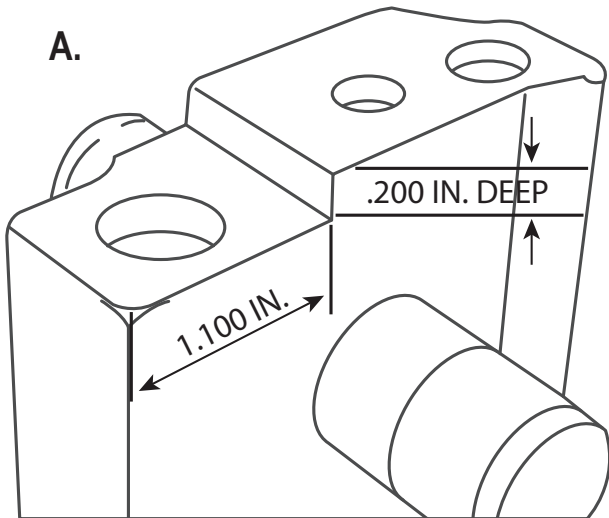

A. Rocker Arm Pedestal Modification.

It will be necessary to mill a step in all six pedestals to the specified amount. The step must be parallel (+/- .005 in.) with the bottom of each rocker arm pedestal.

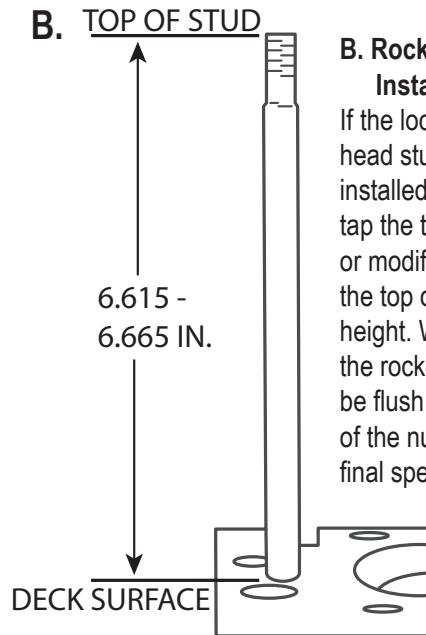

B. Rocker Arm Pedestal Head Stud Installed Height.

If the location of the rocker arm pedestal head studs are above the specified installed height, it will be necessary to tap the threads deeper in the block and/or modify the thread counterbore to get the top of the studs down to the specified height. When installed properly the tops of the rocker arm pedestal head studs should be flush with or just slightly above the tops of the nuts when the head is torqued to its final specification.

Disclaimer and Liabilities

Seller disclaims any responsibility/ liability for improper, incorrect, or inexperienced installation of products by the purchaser or installer resulting in damage or loss. Buyer affirms by purchase of this product that it is fit for intended use and accepts all liability. Buyer affirms products are used at buyers own risk and accepts full responsibility.



FOLLOW US
@GATORFASTENERS

TAG US #GATOR #GATORFASTENERS #NOTHINGBITESLIKE

WWW.GATORFASTENERS.COM