



# ***BD Cam Castor Adjustor***

***Ford Powerstroke 2005-2010 Models***







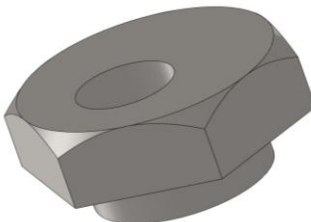

**P/N# 1032100**

**PLEASE READ ALL INSTRUCTIONS BEFORE INSTALLATION**

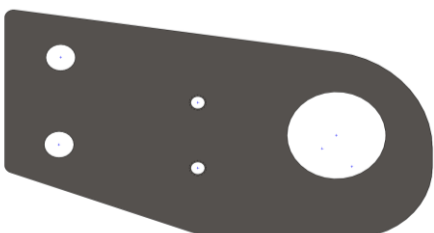
**\*\* A certified welder will be required for welded connections \*\***

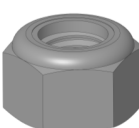
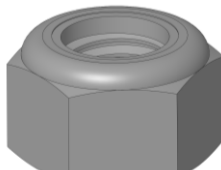
## **KIT CONTENTS:**

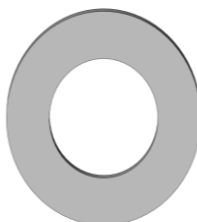
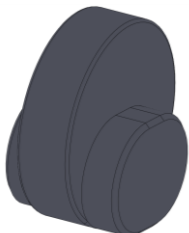
Please check to make sure that you have all the parts listed in this kit **before** you start the disassembly of your truck.

<b>1302102</b>		<b>1302103</b>		<b>1302101</b>	
					
<i>Cam Castor Adjustment</i>		<i>Retaining Plate Castor Adj.</i>		<i>Cam Holder Castor Adjustment</i>	
<b>Qty: 4</b>		<b>Qty: 4</b>		<b>Qty: 4</b>	
<b>1302106</b>	<b>1453127</b>	<b>1302111</b>	<b>1302109</b>	<b>1302108</b>	
					
<i>Bolt M6</i>	<i>M10 Washer</i>	<i>Nyloc Nut M10</i>	<i>Nut M18</i>	<i>Bolt M10</i>	
<b>Qty: 8</b>	<b>Qty: 8</b>	<b>Qty: 8</b>	<b>Qty: 2</b>	<b>Qty: 8</b>	
<b>1302107</b>		<b>1302110</b>		<b>1302105</b>	<b>1302104</b>
					
<i>Bolt M18</i>		<i>Washer M18</i>		<i>Jig Castor Adjustment</i>	<i>Hole saw 1 3/8"</i>
<b>Qty: 2</b>		<b>Qty: 4</b>		<b>Qty: 1</b>	<b>Qty: 1</b>

BD Engine Brake Inc.

Plant Address: 33541 MacLure Rd. Abbotsford, BC, Canada V2S 7W2

U.S. Shipping Address: 88-446 Harrison St, Sumas, WA 98295 U.S. Mailing Address: P.O. Box 231, Sumas, WA 98295

Phone: 604-853-6096 | Fax: 604-853-8749 | Internet: www.bd-power.com

## ***Welcome***

Thank you for purchasing a BD Cam Castor Adjustor. This manual is divided into different areas to assist you with the installation and operation of your Cam Castor adjustor.

Installation should occur on a vehicle properly secured to prevent rolling. Always wear your eye and ear protection when using power tools and avoid inhaling any fumes when cleaning, prepping or welding.

For the ultimate in control of your castor you can install a secondary kit (PN# 1032101) on the top mounts as well.

## ***Required Tools***

- 18 mm Socket/Wrench
- (x2) 2" Open End Wrench
- 24 mm or 15/16" wrench
- 10.5 mm or 27/64" Drill Bit
- Hole Saw Arbor
- File/Flap Wheel
- 1/2" Drive Torque Wrench up to 250 ft/lbs
- 3/8" Drive Torque Wrench 10-100 ft/lbs
- 1/4" Drive Torque Wrench in/lbs
- MIG or TIG Welder

BD Engine Brake Inc.

Plant Address: 33541 MacLure Rd. Abbotsford, BC, Canada V2S 7W2

U.S. Shipping Address: 88-446 Harrison St, Sumas, WA 98295 U.S. Mailing Address: P.O. Box 231, Sumas, WA 98295

Phone: 604-853-6096 | Fax: 604-853-8749 | Internet: [www.bd-power.com](http://www.bd-power.com)

**INSTALLATION**

**VEHICLE SHOULD BE SAFELY SECURED BEFORE INSTALLATION.**

1. With the vehicle on a hoist, block the wheels and set the parking brake.

2. Remove the ABS wire support brackets from both radius arms.

**NOTE:** Depending on the model there will be a push in clip or a 13mm bolt.

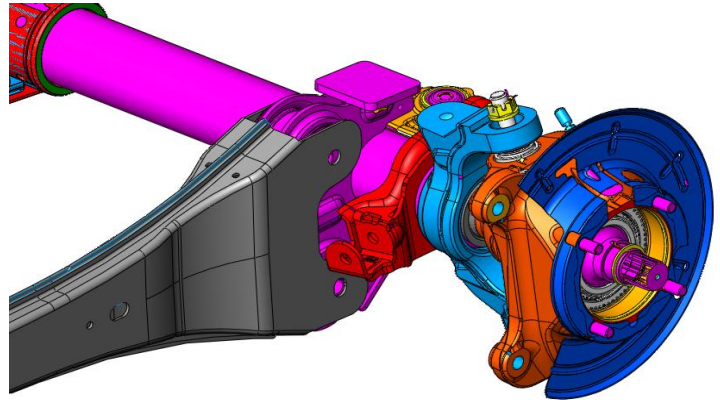

3. Remove the lower mounting bolts on the shock absorber from both sides of the vehicle. (18mm socket) then move the bottom of the shock out of the mount.

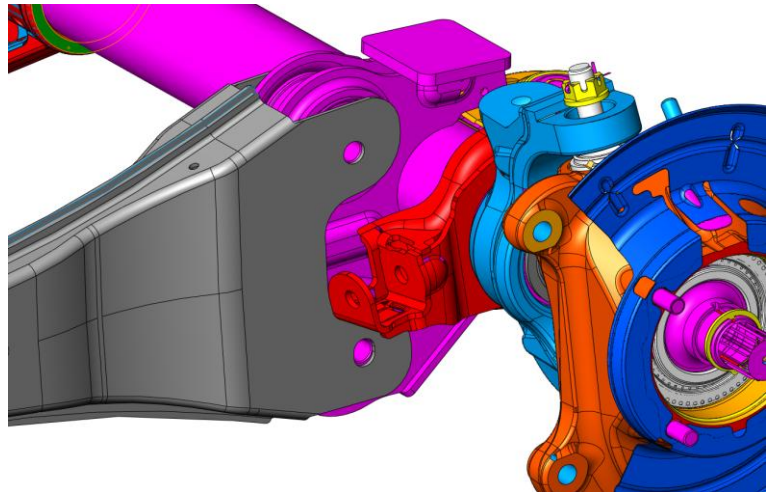

BD Engine Brake Inc.

Plant Address: 33541 MacLure Rd. Abbotsford, BC, Canada V2S 7W2

U.S. Shipping Address: 88-446 Harrison St, Sumas, WA 98295 U.S. Mailing Address: P.O. Box 231, Sumas, WA 98295

Phone: 604-853-6096 | Fax: 604-853-8749 | Internet: [www.bd-power.com](http://www.bd-power.com)

4. Loosen the three mounting bolts located on both radius arms and remove the rear mounting bolt on the passenger side radius arm. (24mm or 15/16" wrench)

**NOTE:** DS front upper mounting nut is welded to the radius arm.

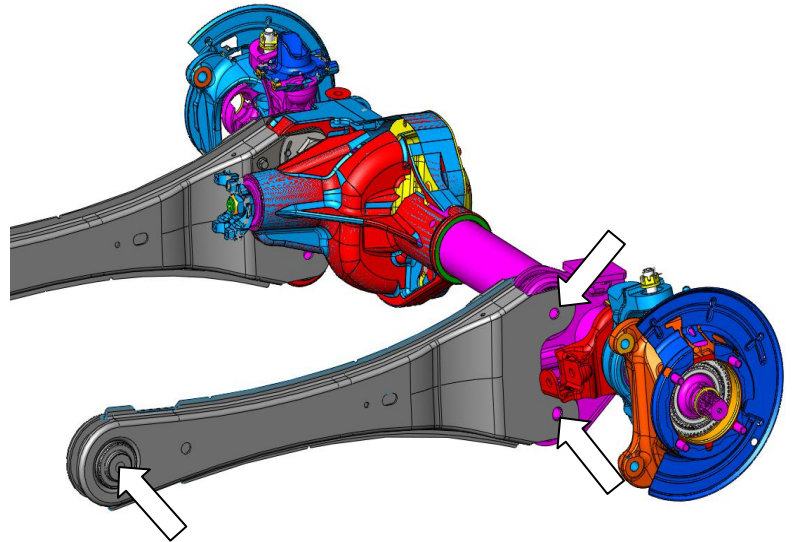

5. Removing the front two bolts on the passenger side radius arm, will release the arm from the vehicle.

**Important:** The lower section of the shock will need to be moved away, to gain access to the bolts.

Refer to step 13 for driver side arm.

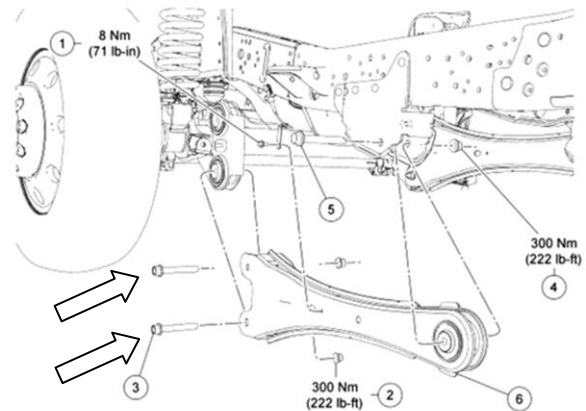

**NOTE:** These steps will be required for both sides of both radius arms.

6. Clean & Prep the control arm on both sides.

**Important:** Steps 6-9 are only to be done to the lower mounting holes only.

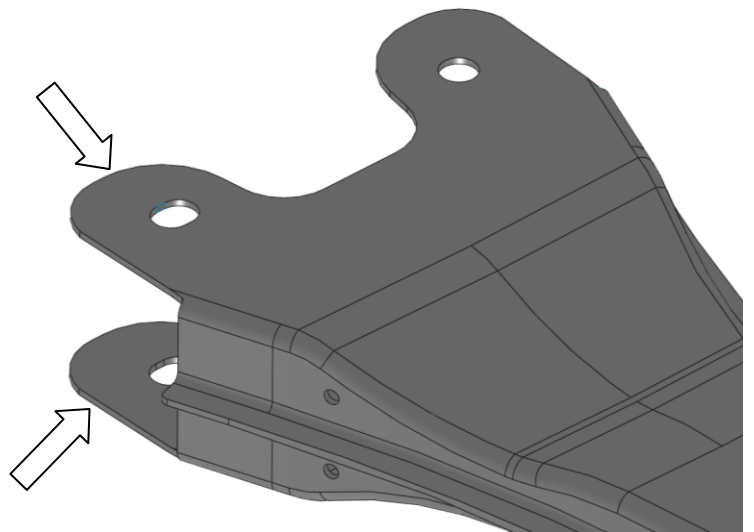

7. Insert the locating jig (1302105) into the radius arm and place the plate onto the locating jig, set the plate's position by ensuring the bottom edge of the plate is parallel with the edge of the radius arm & weld a several 1/16" fillet x 1/4-1/2" long into place.

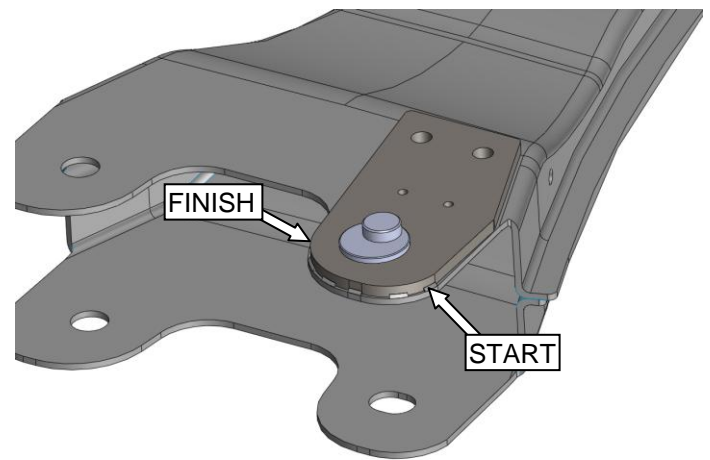
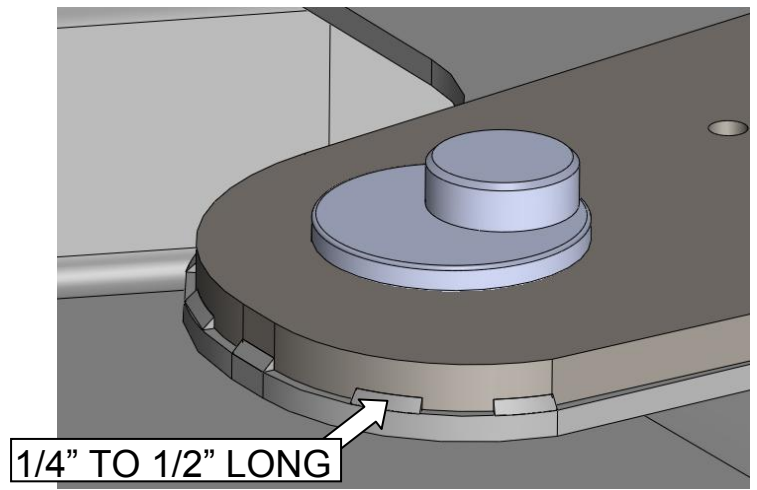

8. Using the plate to locate the hole positions drill the radius arm with the recommended 10.5mm drill bit or a 27/64" drill bit will do as well.

Once completed insert the supplied M10 bolts and nuts into the radius arm. (13mm wrench and socket) and torque to 23 ft/lbs.

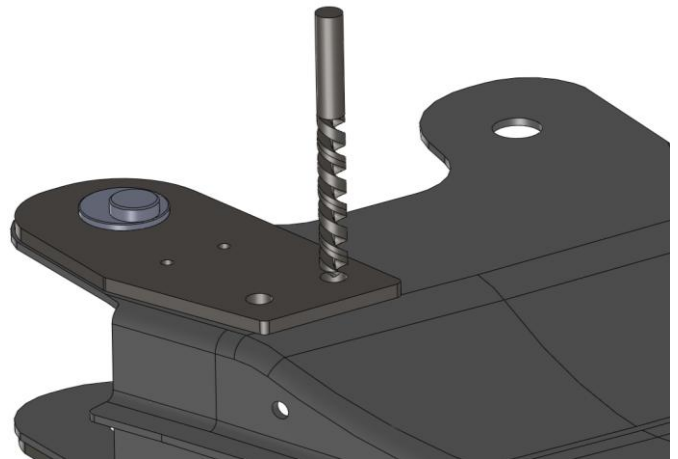

9. You can now remove the locating jig and enlarge the large hole with the supplied 1 3/8" hole saw.

Deburr the now larger hole with a file or flap wheel until the cam castor moves freely.

**Important:** Ensure to coat all bare metal with rust inhibitor ensuring the cam castor still moves freely.

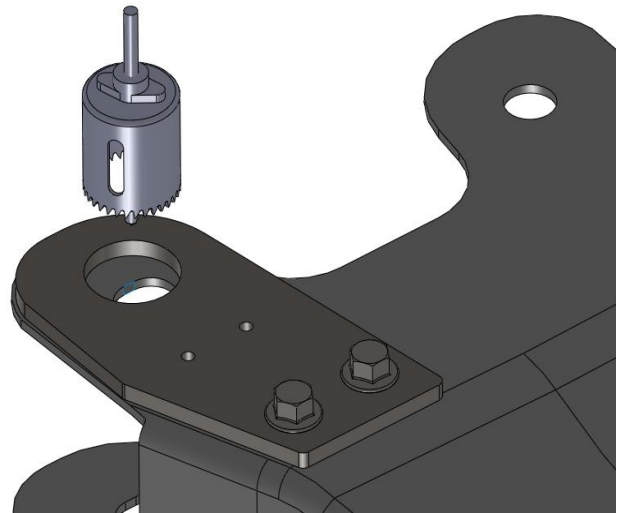

10. Reinstall the radius arm by installing the factory top bolt first.

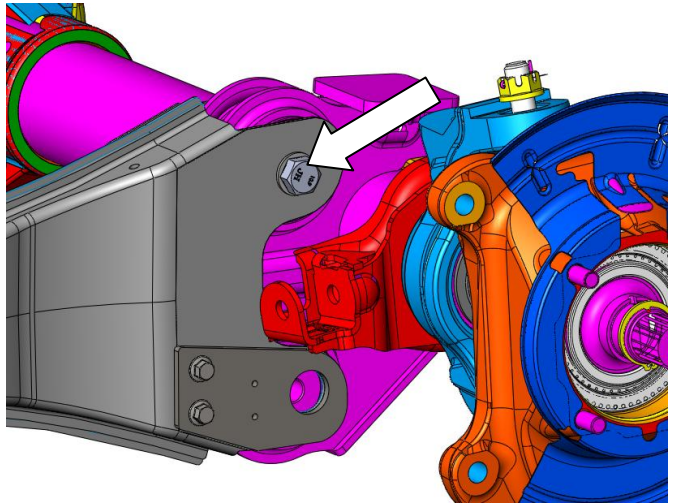

11. Install the supplied castor adjustors (1302101) into the lower connection using the supplied bolt (1302107), washers (1302110) and nut (1302109) do not completely tighten.

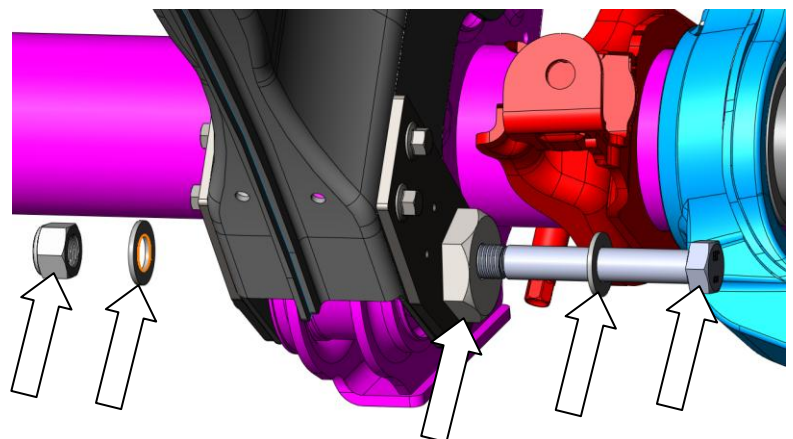

12. Install the rear factory mounting bolt do not completely tighten.

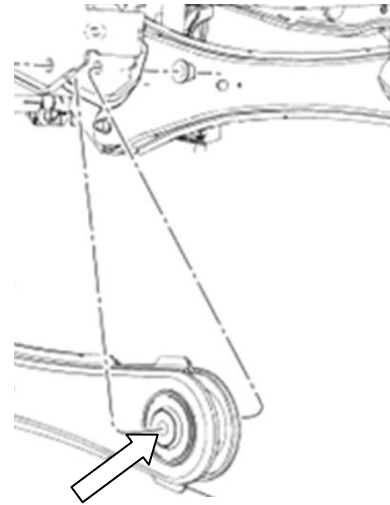

13. On the driver side remove the rear mounting bolt on the radius arm (24mm or 15/16" wrench). Then repeat the removal procedure following step 5.

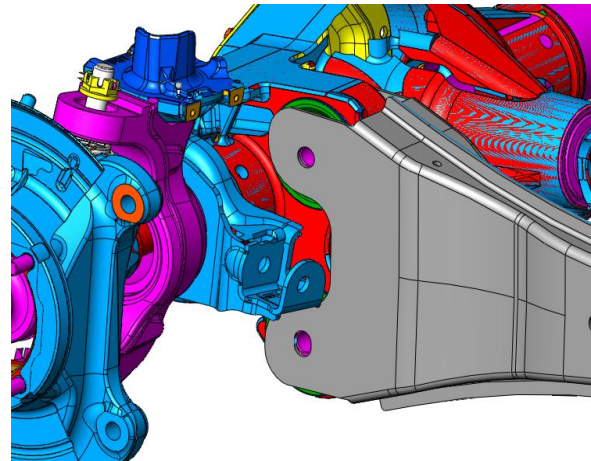

14. Repeat the arm modifications on the driver side radius arm following steps 6,7,8 and 9.

15. Reinstall the driver side radius arm following steps 10 to 11.

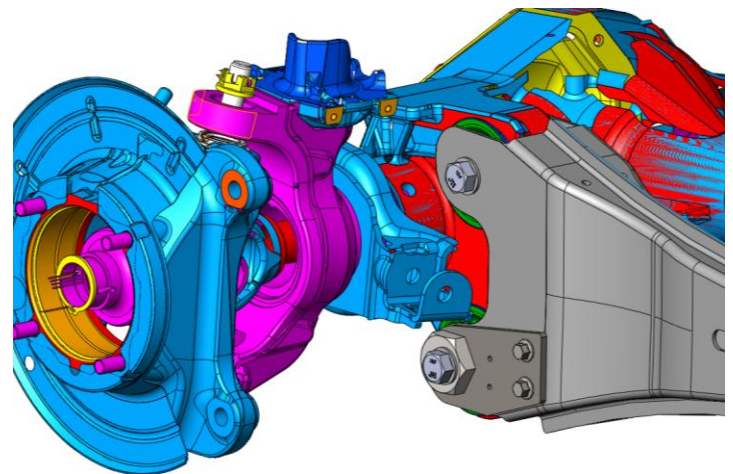



16. Now using two 2" box end wrenches rotate the adjustment cam until the bolt is at the most forward position on both DS/PS arms.

**IMPORTANT\*** The bushing has no resistance on it in the starting and final positions. However in all positions between the starting and final, the bushing is compressed and it is undesirable to leave it in those positions as the bushing will wear faster than expected.

If you require greater adjustment we suggest the use of a secondary kit (P/N# 1032101) that can be installed on the top mounting position of the arm.

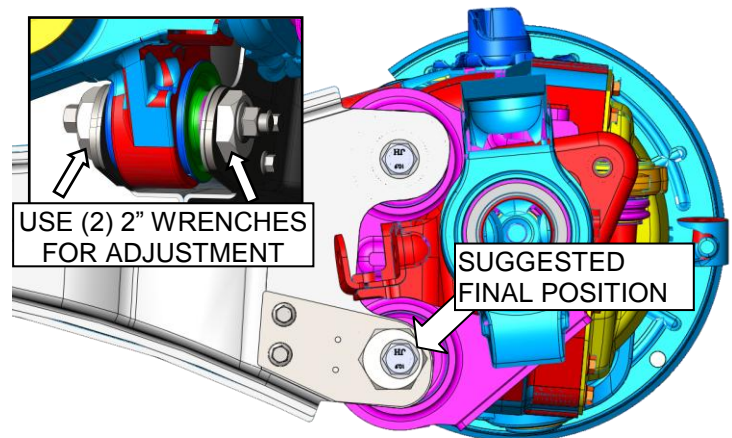
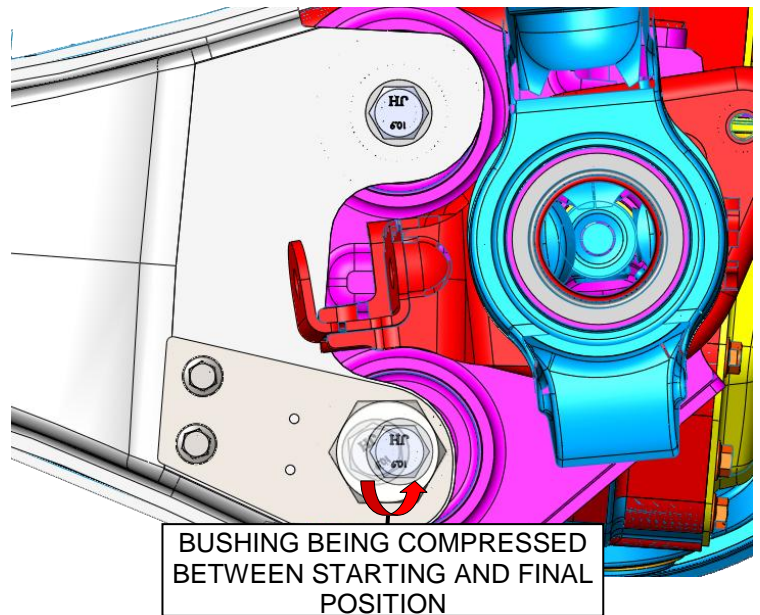
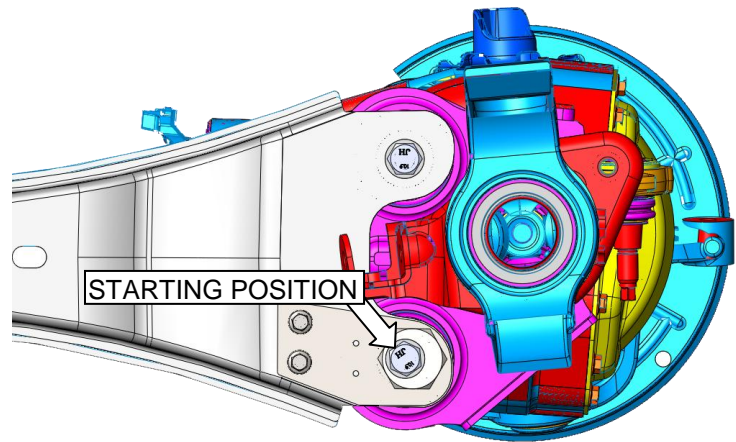

17. Install the lock plates (1302102) over the adjustment cams on each side of the arm and use the supplied lock plate bolts (1302106) to hold the plate down. Do both arms DS/PS and do not tighten completely.

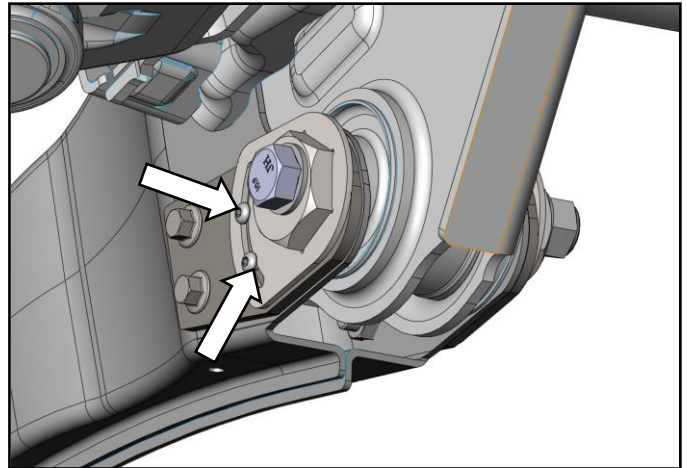
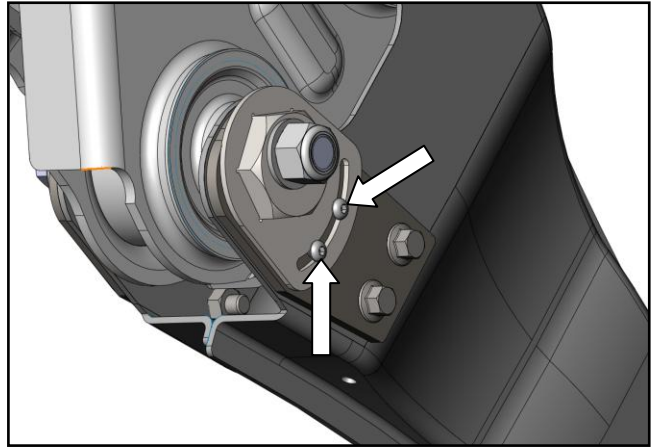

18. Adjust the adjustment cams so they are even on both sides and torque the lock plate bolts to 89 in/lbs. **Then torque all radius arm (M18) mounting bolts to 222ft/lbs on DS/PS.**

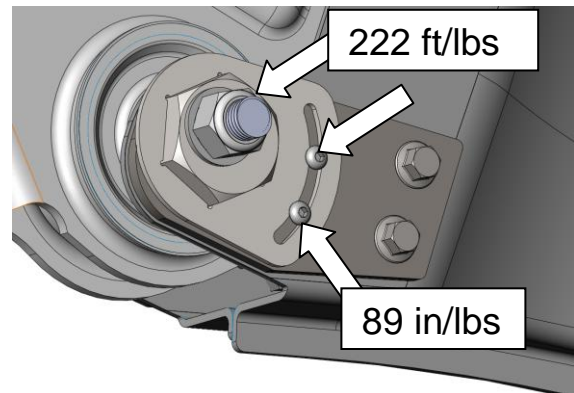

19. Reinstall the shock absorber lower bolt on the DS/PS and torque to 111 ft/lbs.

Reinstall ABS wire support brackets and torque to 13 ft/lbs.

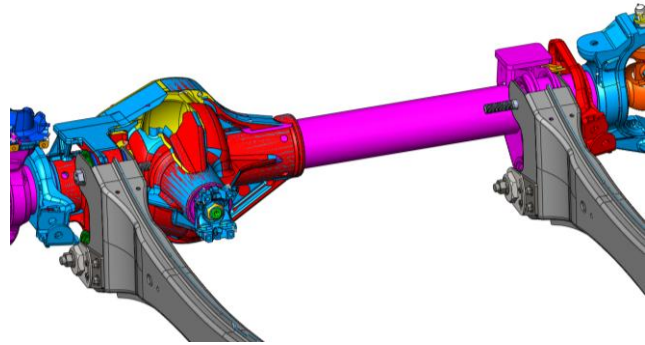

The vehicle is now ready for a front end alignment. We suggest the vehicle be taken to an alignment shop for proper alignment. The suggested factory height castor angle is 1.2°-2.5°. If the vehicle is lifted the suggested castor angle is 4.0°- 4.5°



**DO NOT DRIVE THE VEHICLE WITHOUT COMPLETING A PROPER ALIGNMENT.**

**If you have any technical difficulties, concerns, comments, or complaints, please phone our Technical Support hotline at (800) 887-5030 between 8:30am-5:00pm PST (Pacific Standard Time) Monday to Friday, or post a message on the BD Discussion Forums located at:**

**<http://forum.bd-power.com/>**



Visit our Internet forums at <http://www.dieselpower.com> and share your comments or technical support questions with some of the industry's leading experts in the diesel field.

BD Engine Brake Inc.

Plant Address: 33541 MacLure Rd. Abbotsford, BC, Canada V2S 7W2

U.S. Shipping Address: 88-446 Harrison St, Sumas, WA 98295 U.S. Mailing Address: P.O. Box 231, Sumas, WA 98295

Phone: 604-853-6096 | Fax: 604-853-8749 | Internet: [www.bd-power.com](http://www.bd-power.com)