

make sure door handles are unlocked before installing

- Do not tighten any hardware completely unless noted.
- Passenger side installation shown.

Door Cleaning:

- Do not use Rain-X®, Plexus® or any other protector, wax, or polish.
 - Do not use window cleaning fluids (Windex, 409, etc) or any solvents (gasoline, denatured alcohol, acetone, etc).
 - Never use abrasive cleaners, abrasive pads, or gritty cloths.
 - Never use razor blades, scrapers, squeegees, brushes, etc.
1. Thoroughly rinse Doors to float off dirt and mud.
 2. Using a soft cloth, or microfiber cloth, clean Doors with warm water and a gentle detergent. Baby shampoo, rubbing alcohol, or hand washing soap can also be used.
 3. To prevent water spots, use a chamois to blot Doors dry.

Liability Statement

SuperATV's® products are designed to best fit user's ATV/UTV under stock conditions. Adding, modifying, or fabricating any factory or aftermarket parts will void any warranty provided by SuperATV® and is not recommended. SuperATV's® products could interfere with other aftermarket accessories. If user has aftermarket products on machine, contact SuperATV® to verify that they will work together.

Although SuperATV® has thousands of satisfied customers, user should be aware that installing lift kits, long travel, or suspension kits, tires, etc. will change the ride of machine and may increase maintenance and part wear. Operating any off-road machine while, or after, consuming alcohol and/or drugs increases risk of bodily harm or death. No warranty or representation is made as to this product's ability to protect user from severe injury or death. SuperATV® urges operators and occupants to wear a helmet and appropriate riding gear at all times.

By purchasing and installing SuperATV® products, user agrees that should damages occur, SuperATV® will not be held responsible for loss of time, use, labor fees, replacement parts, or freight charges. SuperATV®, nor any 3rd party, will not be held responsible for any direct, indirect, incidental, special, or consequential damages that result from any product purchased from SuperATV®. The total liability of seller to user for all damages, losses, and causes of action, if any, shall not exceed the total purchase price paid for the product that gave rise to the claim.

SuperATV® will warranty only parts provided by SuperATV®. Any damage or problems with OEM housings, bearings, seals, or other manufacturers' products will not be covered by SuperATV®. SuperATV® parts and products are not warranted if item was not installed properly, misused, or modified.

Installing, adding, modifying, or fabricating any factory or aftermarket product to your ATV/UTV may violate certain local, state, and federal laws. Be advised that laws vary depending on town, city, county, state, etc. Use of certain products on public streets, roads, or highways may be in violation law. The Buyer is solely and exclusively legally and personally responsible for any violation of the law by the installation or use of the product. You must abide by all local, state, and federal laws, including but not limited to vehicle safety, traffic laws, and ordinances. It is your responsibility to know the laws and how they apply to you.

The Buyer is responsible to fully understand the capability and limitations of his/her vehicle according to manufacturer specifications, warnings and instructions and agrees to hold SuperATV® harmless from any damage resulting from failure to adhere to such specifications, warnings and/ or instructions. The Buyer is also responsible to obey all applicable federal, state, and local laws and ordinances when operating his/her vehicle while using this product, and the Buyer agrees to hold SuperATV® harmless from any violation thereof.

Need help with your installation?



sales@superatv.com



www.superatv.com



1-855-743-3427



8:00am - 8:00pm EST M-Th
8:00am - 7:00pm EST Friday
9:00am - 2:00pm EST Saturday

Read instructions and view illustrations before beginning.

Thank You

For Choosing





Foam



Mirrors



K



U

J



A

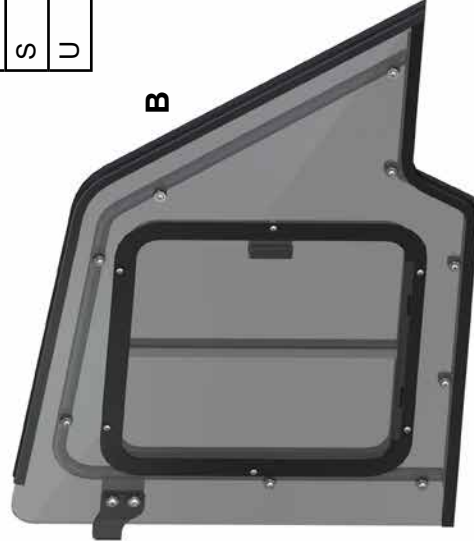

B

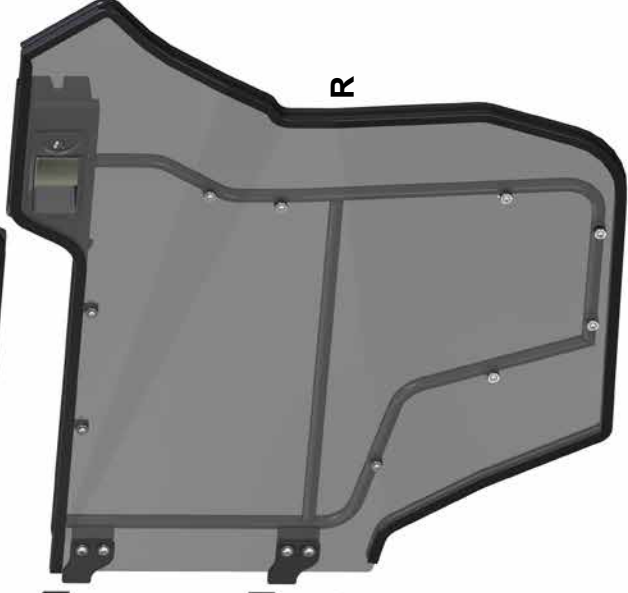

Q

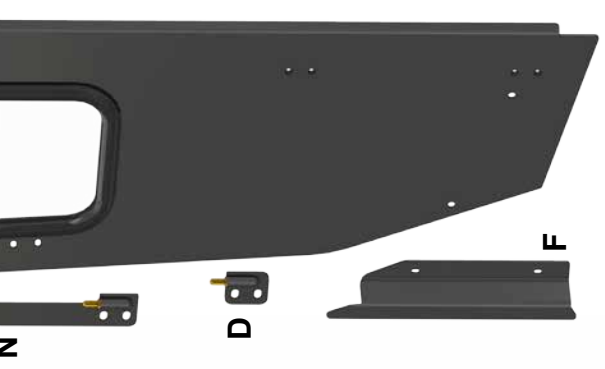

R

Item	Description	Item	Description
A	Left Upper Door	F	Right Bracket
B	Right Upper Door	G	Right Striker
C	Left Male Hinge	H	Left Striker
D	Right Male Hinge	J	Clamp x 4
E	Left Bracket	K	Gas Strut x 2
L	Right Support	M	Left Support
N	Right Hinge Assembly	P	Left Hinge Assembly
Q	Left Lower Door	R	Right Lower Door
S	Left Hinge Mount	T	Right Hinge Mount
U	Tube Clamp x 2		

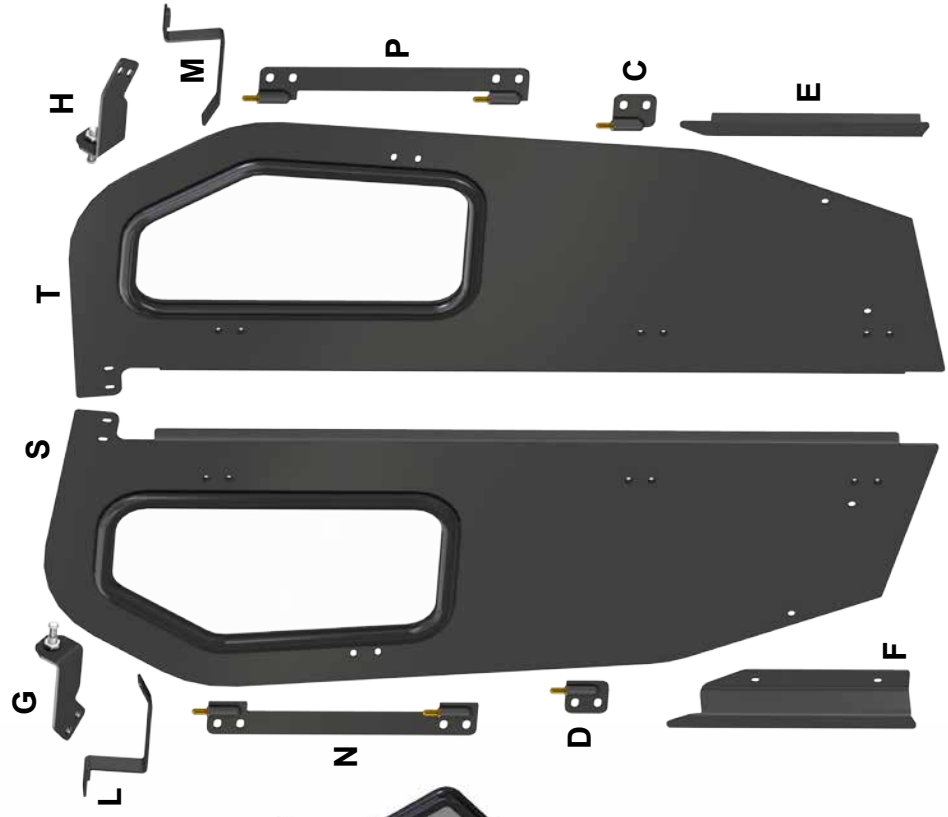

- Remove stock Doors.



- Install Right Bracket (F) and Right Striker (G) with hardware shown.

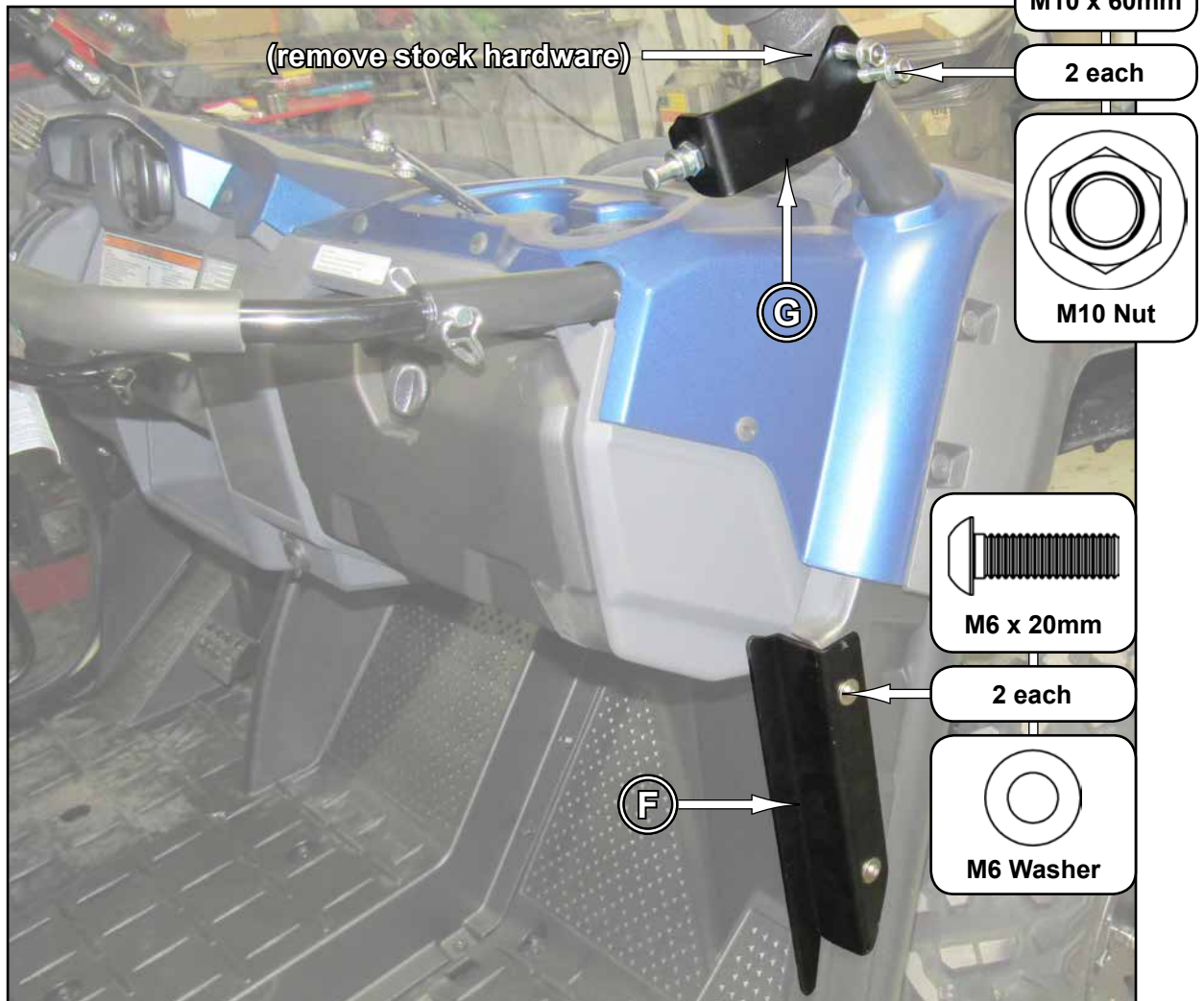

- Install Tube Clamp (U) around Cage in location shown; do not tighten hardware.
- Place Right Support (L) in location shown.

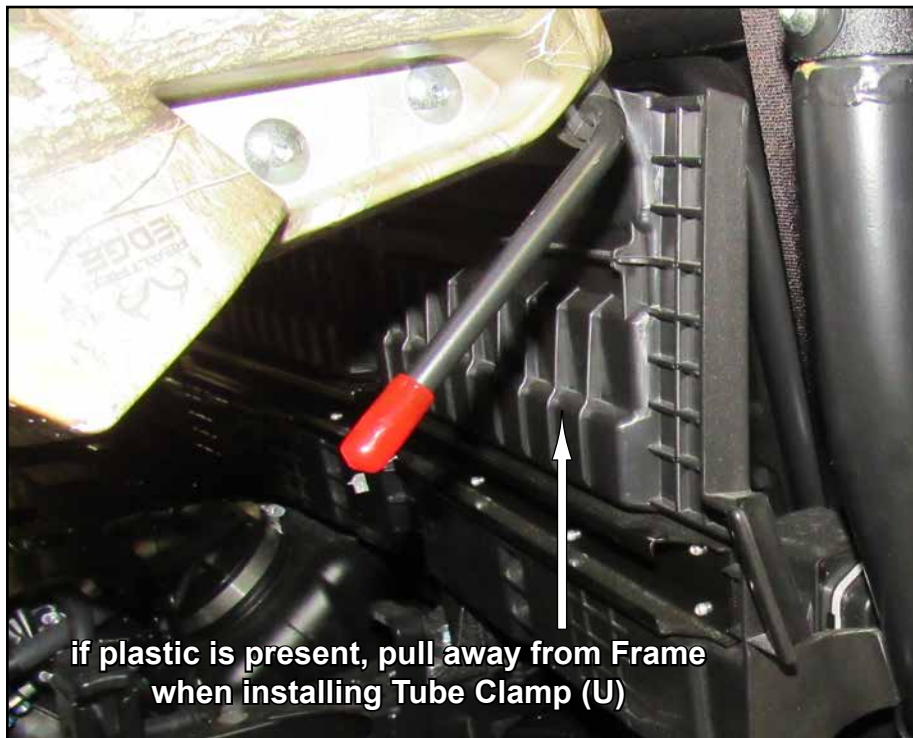

if plastic is present, pull away from Frame
when installing Tube Clamp (U)

- Install Clamps (J), Right Male Hinge (D), and Right Hinge Assembly (N) to Right Hinge Mount (T) with hardware shown.



- Cut and install Foam to locations shown.

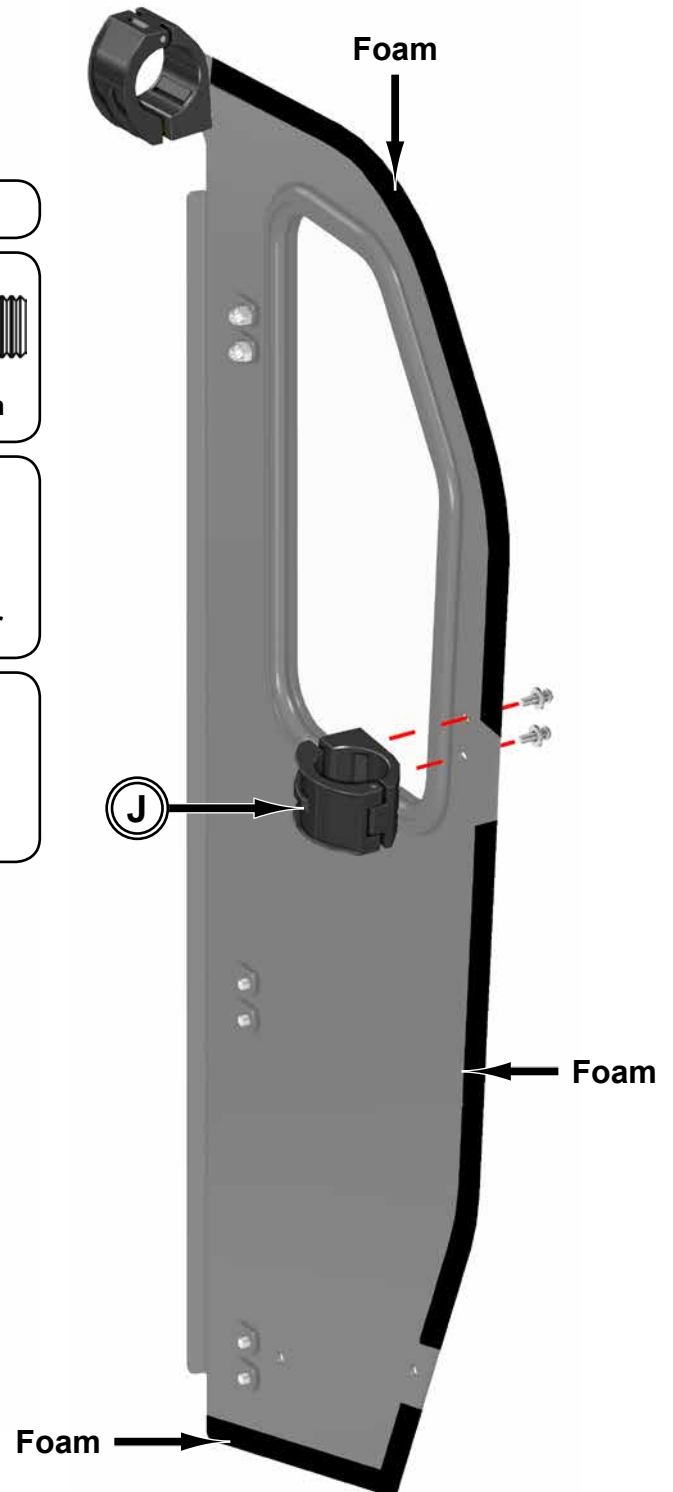

- Secure Right Hinge Mount (T) to previously installed Tube Clamp (U) and Right Support (L) with hardware shown.
- Secure Clamps (J) around Cage; use previously removed Clamps (J) hardware.
- Install Foam to location shown.

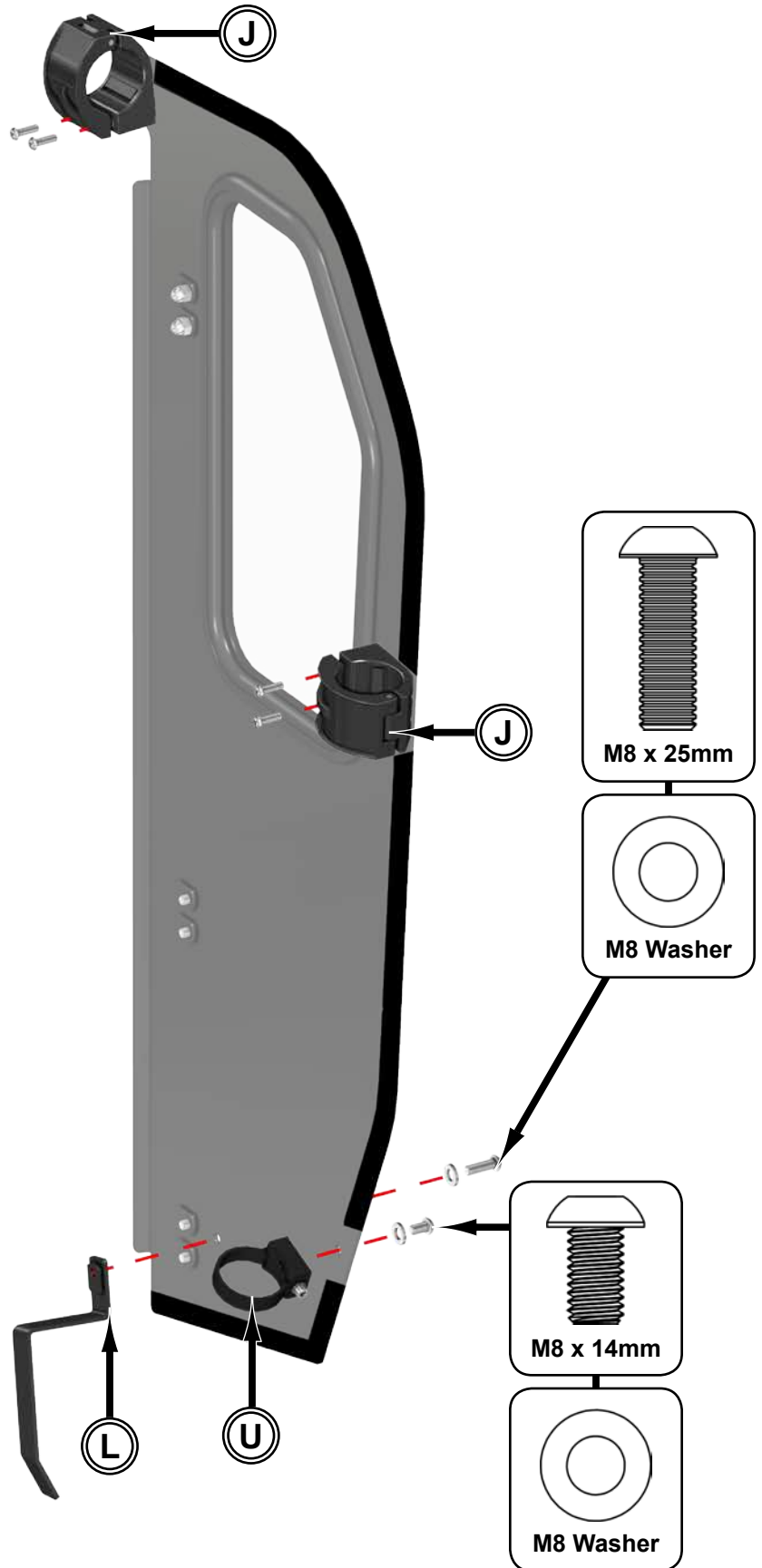

- Join Right Upper Door (B) and Right Lower Door (R) with hardware shown. Tighten hardware completely.

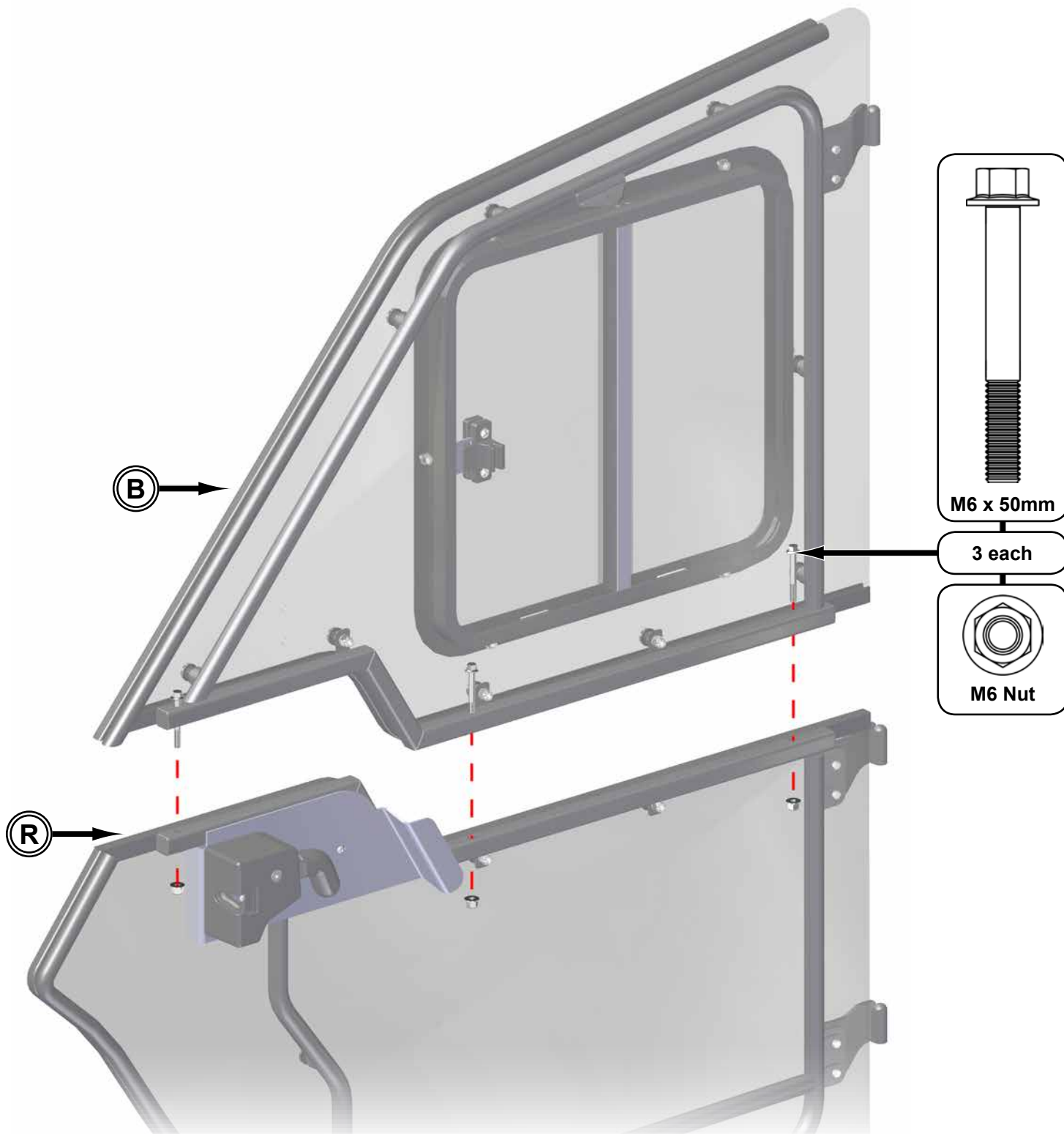

- Hang Door on Right Hinge Assembly (N) and Right Male Hinge (D).



- Close Door and engage Latch.
- Align to machine and tighten all hardware completely; see following page.



start with rear most locations and work
towards front when adjusting Door



(when adjusting, use highlighted bolts)

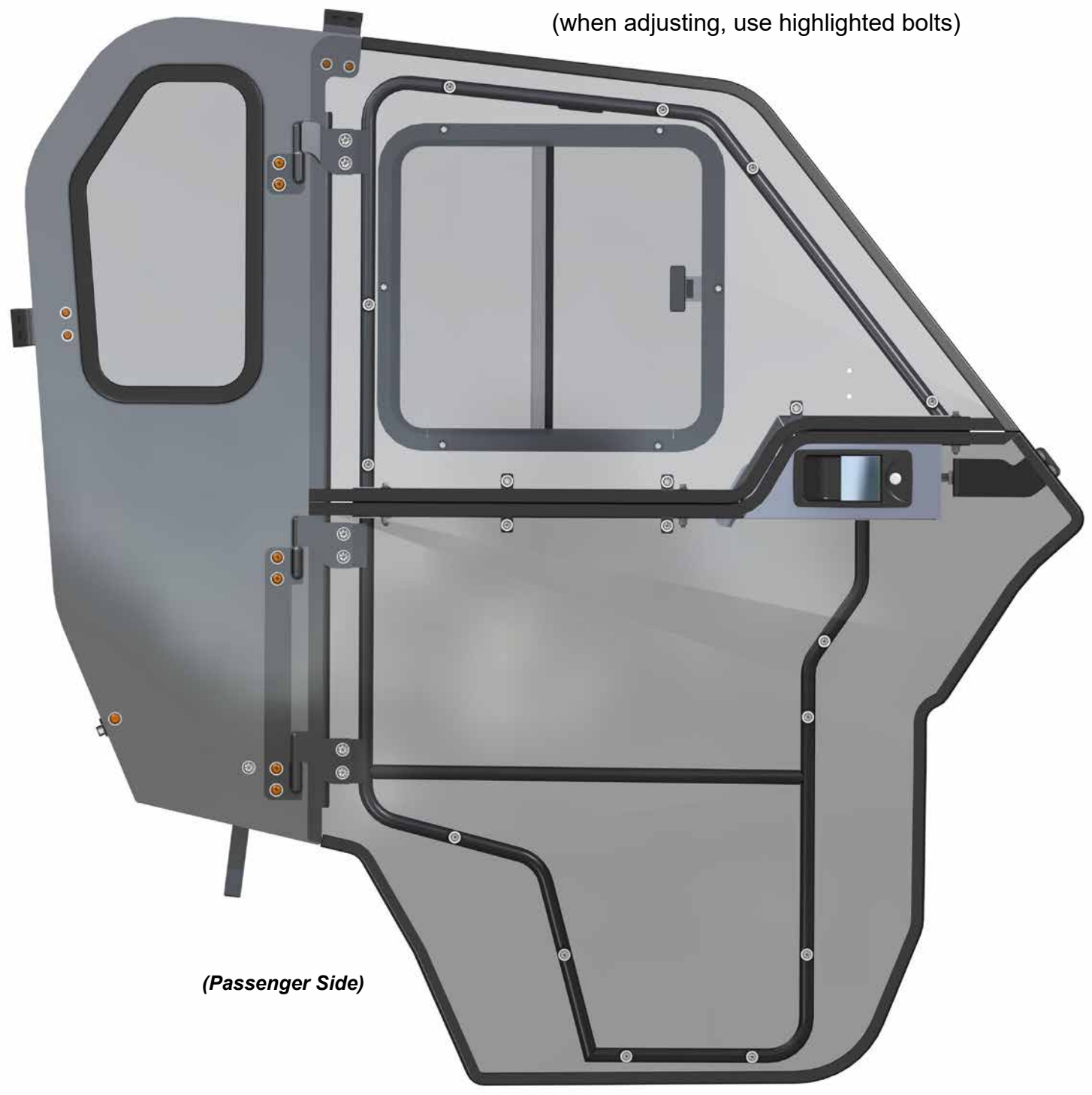

(Passenger Side)

- Install Gas Strut (K) to Door and Clamp (J) with hardware shown.



- Remove installed Mounts on Mirrors. Discard Mount and hardware.
- Install Mirrors to Doors with hardware shown.

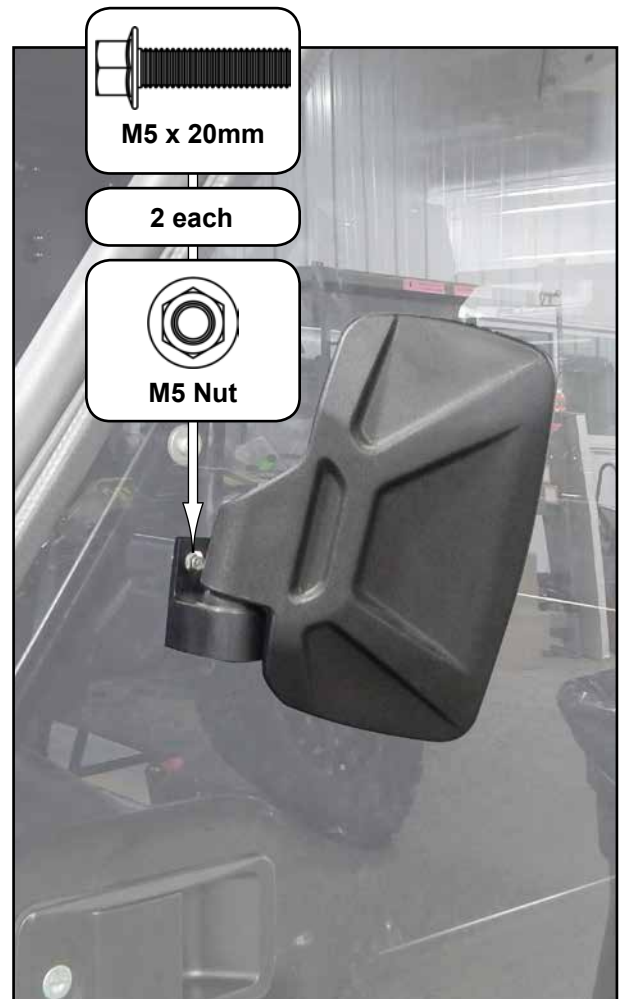
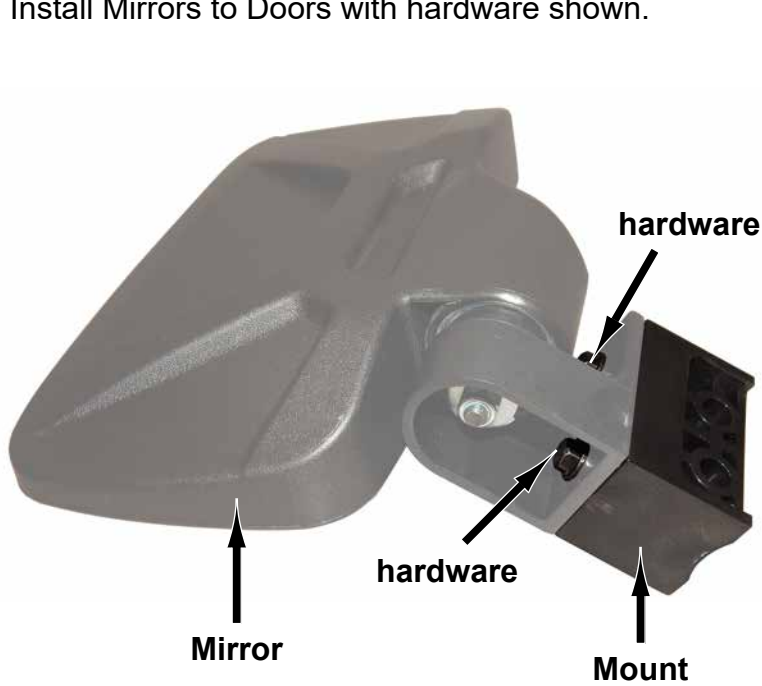

- Repeat steps for opposite side.

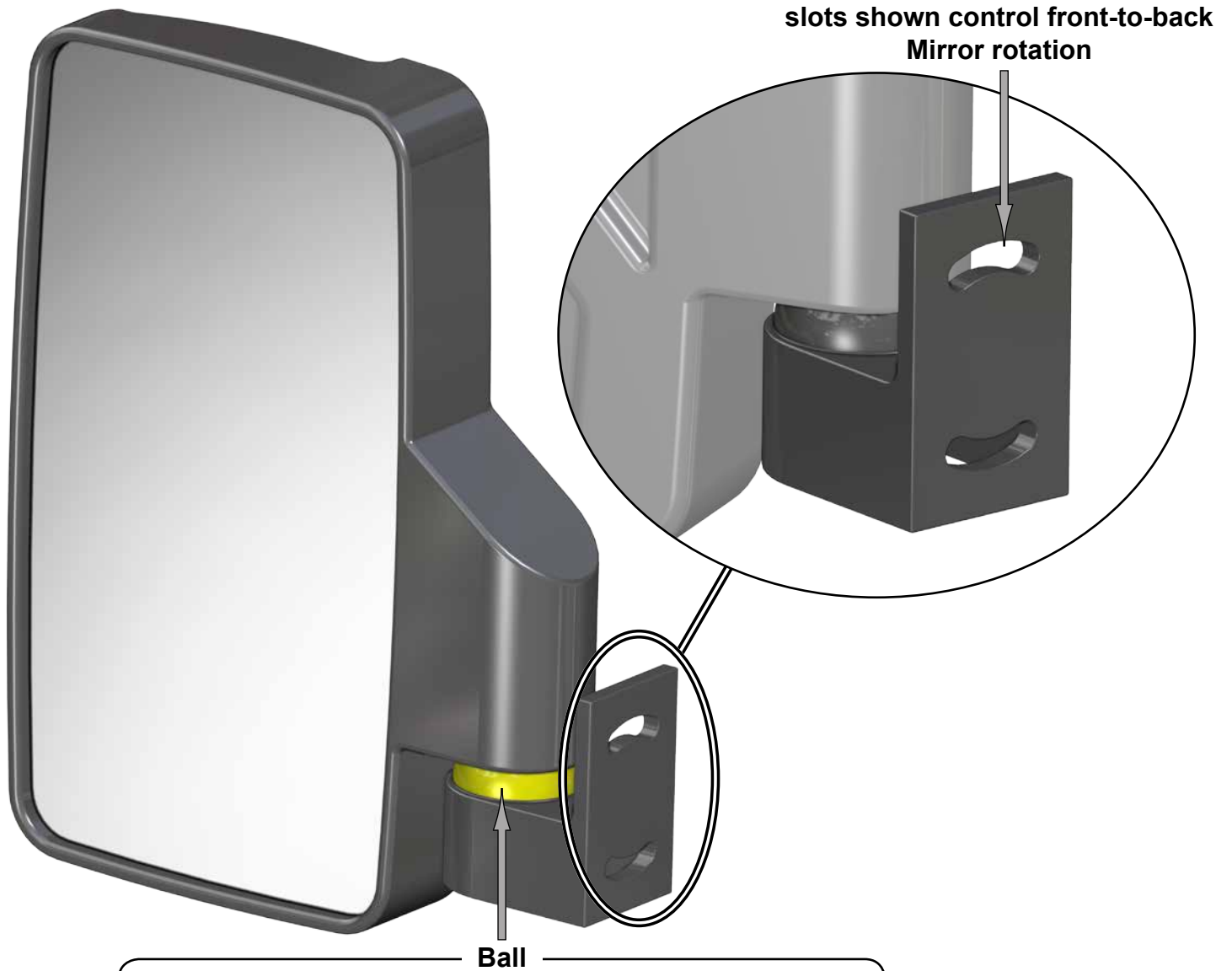

- Mirror is spring loaded and can also be adjusted here.
- Ball will allow adjustment in various directions.



- Remove Roof hardware shown.
- Reinstall after Foam has been installed.

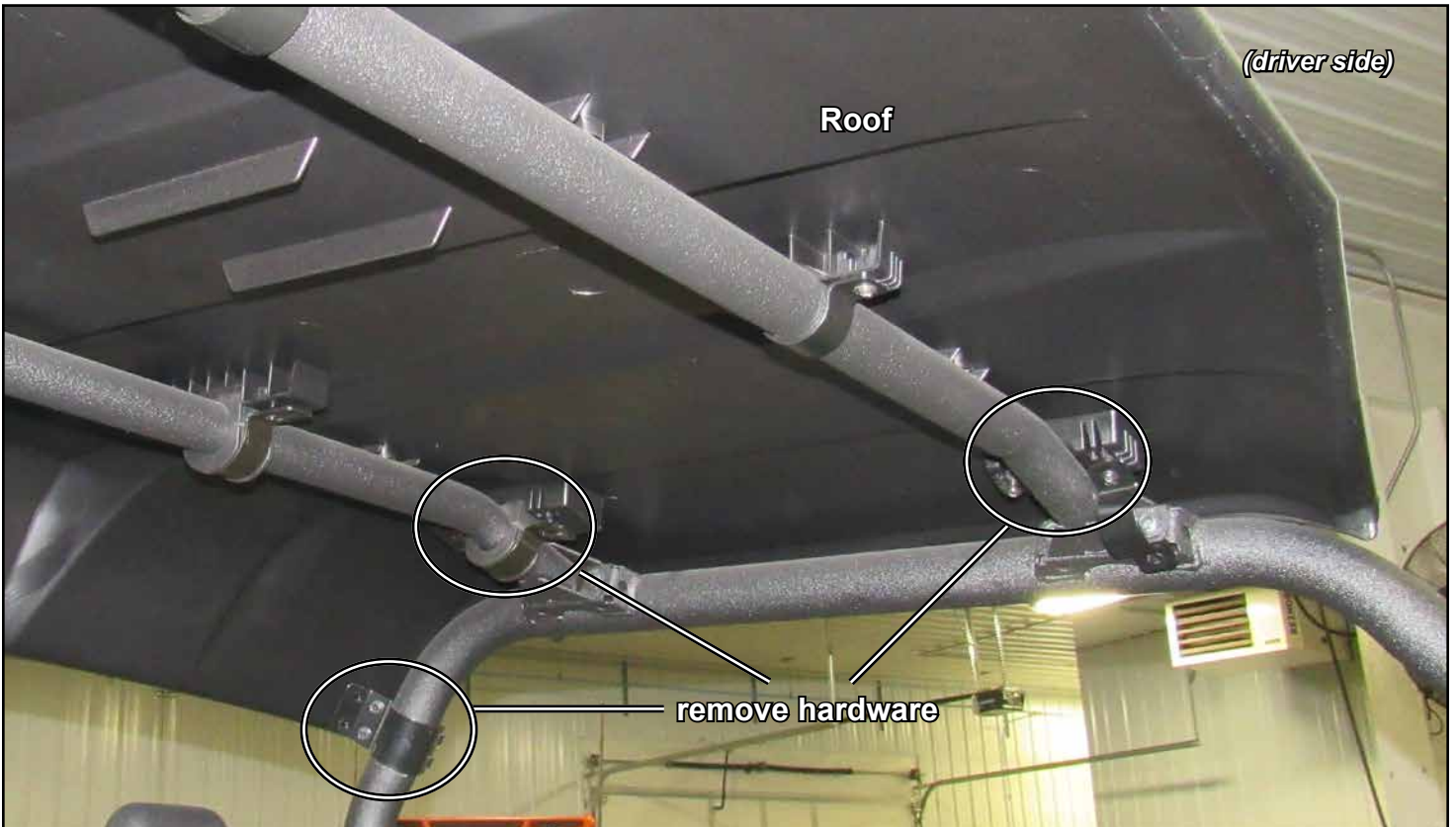

- Install Foam to Cage in locations shown.

