



## 2017+ Maverick X3 (All Models) Frame Gusset Kit # S3117



### INSTALLATION INSTRUCTIONS

# Maverick X3 – Front Frame Gusset Kit



# 2017+ Maverick X3 (All Models) Frame Gusset Kit # S3117

## PARTS LIST

ITEM	PART #	DESCRIPTION	QTY
		Front Frame Plate	1
		Backside Frame Plate	1
		Rear Mount Gusset – Lower A-Arm	1
		Rear Mount – Upper A-Arm	1
		Bolt Kit – S3BK-CMAVX3-GK	1

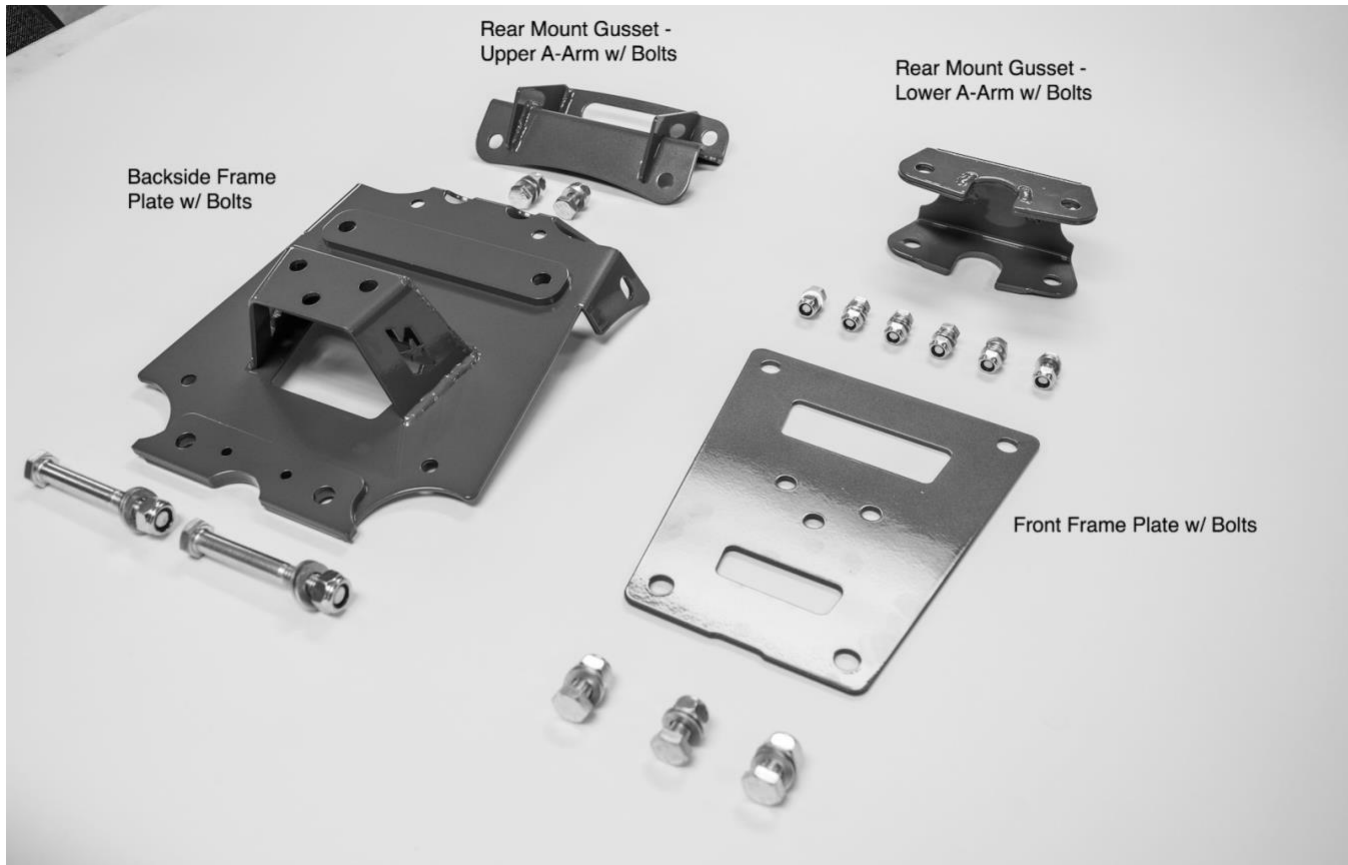



## 2017+ Maverick X3 (All Models) Frame Gusset Kit # S3117

### INSTALLATION

- 1.) Place Maverick X3 on flat solid ground and place in park.
- 2.) Remove cotter pins and axle nuts from each front axle.
- 3.) Remove brake calipers by removing the two bolts that secure caliper to hubs then remove the hub assembly on each side.
- 4.) Remove ball joint pinch bolt and dislocate ball joint from knuckle.
- 5.) Remove shocks from both sides.
- 6.) At this point, you can lift both upper a-arms which allows you to remove the axle from the spindles.
- 7.) Remove upper ball joint nuts and washers. This will now allow you to remove the spindle from the upper ball joint by hitting down on the spindle with a dead blow.
- 8.) Remove the bulkhead from the front of the machine by removing the (4) nuts and the radiator bolts. (Recommendation – secure radiator with a strap to keep it in position.)
- 9.) Remove the nuts and bolts that secure the a-arms and remove all a arms from the frame.
- 10.) Disconnect the tie rod bolts that hold them to the spindle and place the spindles to the side. Tie rods can be left aside, hanging out of the way.
- 11.) Remove the axles from the differential by using a slide hammer (Suggested tool) or by using the “Snatch Method” or by using a small pry bar. **\*\*NOTE – CV will dislocate from back if pulled on too hard using the “snatch method”.**
- 12.) Remove the 4 nuts and washers holding the differential to the frame. These bolts will be located on the bottom side of the frame. **\*\*if you have a small torch, apply small amount of heat to the bolts to loosen threadlocker.\*\***
- 13.) Remove differential from the frame area. Be careful not to turn differential sideways or upside down for too long to avoid fluid loss.
- 14.) Remove the (2) small bolts in front of the frame that hold the “stud pack” in. Remove the stud pack.
- 15.) Remove the (2) small bolts on the side of the frame that holds the black plate to the backside of the frame.
- 16.) Now, you will need to make the necessary modifications to the frame for your gusset plate.
- 17.) Start by drilling the holes in the picture. There are two rivets where you need to drill. Use these as reference points. Using a 21/64” drill bit, drill the holes in the described locations in pictures. NOTE- the holes on the top and sides are pre-existing holes. You will enlarge them with your 21/64” drill bit.
- 18.) Next, clearance your diff tray by grinding slots in the front for the lower control arm bolts to clear. **\*\*See Pics\*\***
- 19.) There are two more holes to drill. To locate these holes, place “front diff” gusset plate into frame with the “S3” logo going through the front frame hole. You may need to insert the frame plate horizontally and then stand it up into place. Go behind the plate to mark the holes shown in the pic. NOTE- If installing an “S3 Shock Tower Brace”, grind down the small welds on the frame. If you are not installing a shock tower kit, disregard.
- 20.) Remove front diff plate and drill the marked holes with a 21/64” drill bit. NOTE- we recommend spray painting the spots that were drilled or had any grinding done to them.
- 21.) Reinstall the gusset plate into the frame and loosely install bolts. Do not tighten at this time.



## 2017+ Maverick X3 (All Models) Frame Gusset Kit # S3117

- 22.) Install lower control arm gusset. Place the gusset onto the tube in front of the rear control arm studs as shown in the pic.
- 23.) Install both lower a-arms at the same time by inserting the rear bushings into the rear lower a-arm gusset and sliding the gusset/control arm over the rear lower mounting studs. NOTE- an assistance is useful here. Optional : remove skid plate and drill out rivets that hold these studs together. S3 prefers this method so you can remove one a-arm at a time but it does require removing the skid plate.
- 24.) Both lower a-arms should be resting downward and only connected by the rear lower a-arm studs in the frame.
- 25.) Set the differential into the frame and connect the drive shaft. Do not install any differential bolts at this time. It is necessary to move the differential during a later step.
- 26.) Install the upper a-arm gusset by using (2) m10x1.5x20 bolts, washers, and nuts. Leave bolts finger tight at this time.
- 27.) Install both upper a-arms. Insert upper a-arms into the rear gusset first and insert the bolts from rear so nuts are facing the differential. Insert bolts in the front so nuts face outwards towards the bulkhead. If you have an X rc or X mr, you will use the supplied m12x1.25-90mm in the front.
- 28.) All a-arm bolts should be installed except front lowers. See Pic. The next few steps will differ depending on your model and/or if you are installing an S3 Bulkhead.
- 29.) If you have a X rc or X mr, install the bulkhead plate now using the (3) m10-1.5x20 button head bolts and red Loctite.
- 30.) If you are using an S3 Bulkhead, you will not use the gusset plate and would install the S3 Bulkhead at this point using the button head bolts.
- 31.) Install the bulkhead by hanging it on the 2 upper a-arm bolts. Thread the factory nuts on the upper bolts and leave loose.
- 32.) Install the lower a-arm bolts through the bulkhead, (bulkhead plate if used), a-arm, and the gusset plate. Use the provided M12 washers. If you have an X ds or X rs, you will use the M12x1.75x85 bolts.
- 33.) Notice the upper a-arm bolts in the bulkhead face outward and the lower bolts face inward. Now install the washers and nuts onto the bolts. This is easiest by sliding the differential around to tighten them. Use red Loctite.
- 34.) If you have an X rc or X mr, there will be an additional bolt at the bottom of the bulkhead from the factory. This additional bolt goes through a spacer and into the frame. There will be a bolt on the top of the spacer that holds the spacer to the bulkhead. Loosen this bolt so you can slide the spacer forward and flush with the frame. Tighten both bolts.
- 35.) Tighten all (8) a-arm bolts using red Loctite. Note- If you spill any Loctite, clean it up immediately as it will stain the powder. Do not use solvents.
- 36.) Tighten the two bolts on the upper a-arm gusset using red Loctite.
- 37.) Now bolt the differential back into the differential tray. \*\*If you are installing our S3 Front Bumper, you will only install the 2 bolts in the rear of the differential. Also, install and tighten the driveshaft pinch bolt. Check differential fluids and replace as necessary.
- 38.) If you have an S3 Shock Tower brace, install it but leave the bolts hand tight. (See Shock tower brace instructions).



## 2017+ Maverick X3 (All Models) Frame Gusset Kit # S3117

- 39.) Reinstall the front axles into the differential. Make sure the circlip is installed before going into the differential. NOTE- if you are having trouble getting the stubs to go into the diff all the way, try turning the driveshaft on the backside of the differential.
- 40.) Install the spindles. Install the upper ball joints into the spindles first. Leave the axle nut out of the spindle so you can have room to tighten the nuts on the upper ball joints. Install the cotter pins into the upper ball joints.
- 41.) Route brake lines and calipers. This will differ whether or not you are using factory a-arms or S3 a-arms. Factory a-arms have the brake lines on top of the upper a-arms and the S3 a-arms have the brake line tabs on the bottom side of the upper a-arm. Do not bolt the caliper down or secure the lines yet.
- 42.) Install lower ball joints pinch bolts into the spindles. This may require some repositioning and some tapping with a small rubber hammer to get the ball joint to go into the spindle. Use red Loctite.
- 43.) Install the tie rods.
- 44.) Install the hubs onto the spindles. Make sure the axle is fully inserted onto the splines and the hub is fully inserted into the wheel bearing. Now install the washer and axle nut. Tighten with an impact using red Loctite.
- 45.) Install brake calipers. Make sure the pads are separated on each side of the rotor. Use red Loctite on brake caliper bolts.
- 46.) Secure brake lines to upper a-arms using factory holders or zip tie them to the supplied brake line tabs on the S3 a-arms.
- 47.) Install sway bar links. Make sure the brake lines are UNDER the sway bar links.
- 48.) Install shocks. There is a left and a right shock. The reservoir will face inward and towards the front of the machine.
- 49.) Install the radiator mounting hardware and tighten. If you have an X rc or X mr, install the winch leads. These will need to be rerouted as well. (See pic)
- 50.) Before installing plastics, check all your work and be sure all bolts are tightened down.
- 51.) Install any plastics you may have removed and install wheels and tires. Perform an alignment if necessary.

\*\*\*NOTE – S3 front bumper will share bumper arm mounting holes with gusset kit and/or shock tower brace if they are installed.\*\*\*

\*\*\*NOTE – If pairing this kit with a shock tower brace kit, grind down welds on front side of frame per the shock tower instructions\*\*\*

Thank you for choosing the S3 Power Sports Gusset Kit. If you have any questions or concerns, please give us a call and speak with our Sales Team. 855-221-7097



## 2017+ Maverick X3 (All Models) Frame Gusset Kit # S3117





## 2017+ Maverick X3 (All Models) Frame Gusset Kit # S3117

Figure B

Use a small die grinder and burr bit to remove excess material from differential tray to allow room for supplied bolts to slide in.

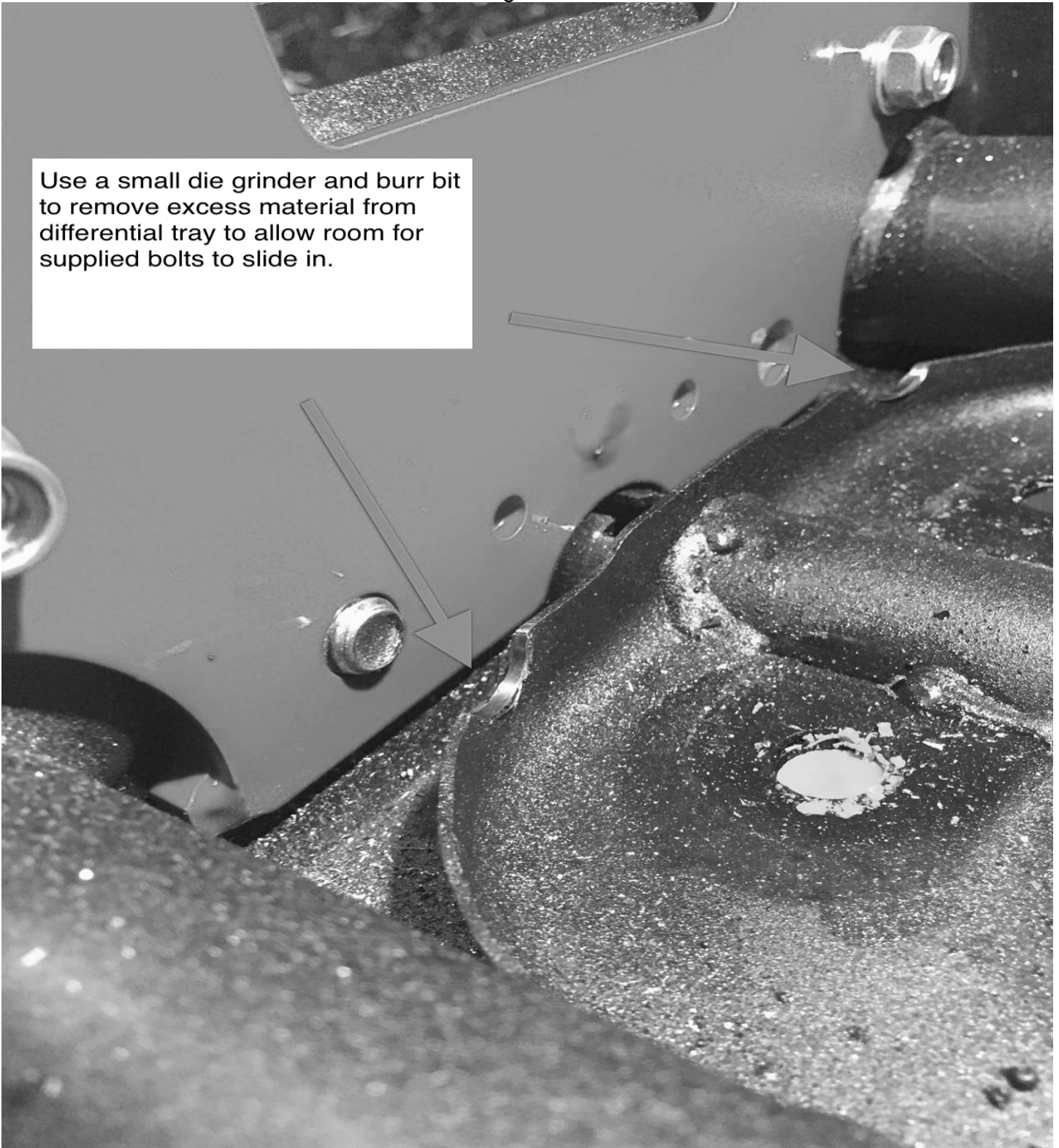



## 2017+ Maverick X3 (All Models) Frame Gusset Kit # S3117

Figure C



Drill holes with 5/16th drill bit to allow roof for supplied bolts. Make sure to drill opposite hole on driver and passenger sides.





# 2017+ Maverick X3 (All Models) Frame Gusset Kit # S3117

Figure D





## 2017+ Maverick X3 (All Models) Frame Gusset Kit # S3117

Figure E





## 2017+ Maverick X3 (All Models) Frame Gusset Kit # S3117

Figure F



\*\*\*To make it easier on this part of the install, you can notch the skid plate to have easier access to the bolts holding the a arms on. There's a small plate holding the bolts in place that you will have to remove the rivets to. After you remove the rivets, you can get to the bolts easier and remove one a-arm at a time. We do not put this in the main instructions because it's not necessary; however, it does make it easier to install the gusset kit and maintenance the machine without having to remove both a arms at once. If you have any questions at all on this process, please give us a call at the shop and we can go over everything with you on the phone! 855-221-7097. \*\*\*

Figure G



## 2017+ Maverick X3 (All Models) Frame Gusset Kit # S3117





## 2017+ Maverick X3 (All Models) Frame Gusset Kit # S3117

Finished Product





## 2017+ Maverick X3 (All Models) Frame Gusset Kit # S3117

