

INSTALLATION INSTRUCTIONS
Gen 3 Portal Gear Hubs - 6"
 Textron Wildcat XX

Item	Description
A	Rotor x 4
B	Left Gear Box x 2
C	Right Gear Box x 2
D	Gasket x 4
E	Cap x 4
F	Recessed Nut x 4
Q	Spacer x 4

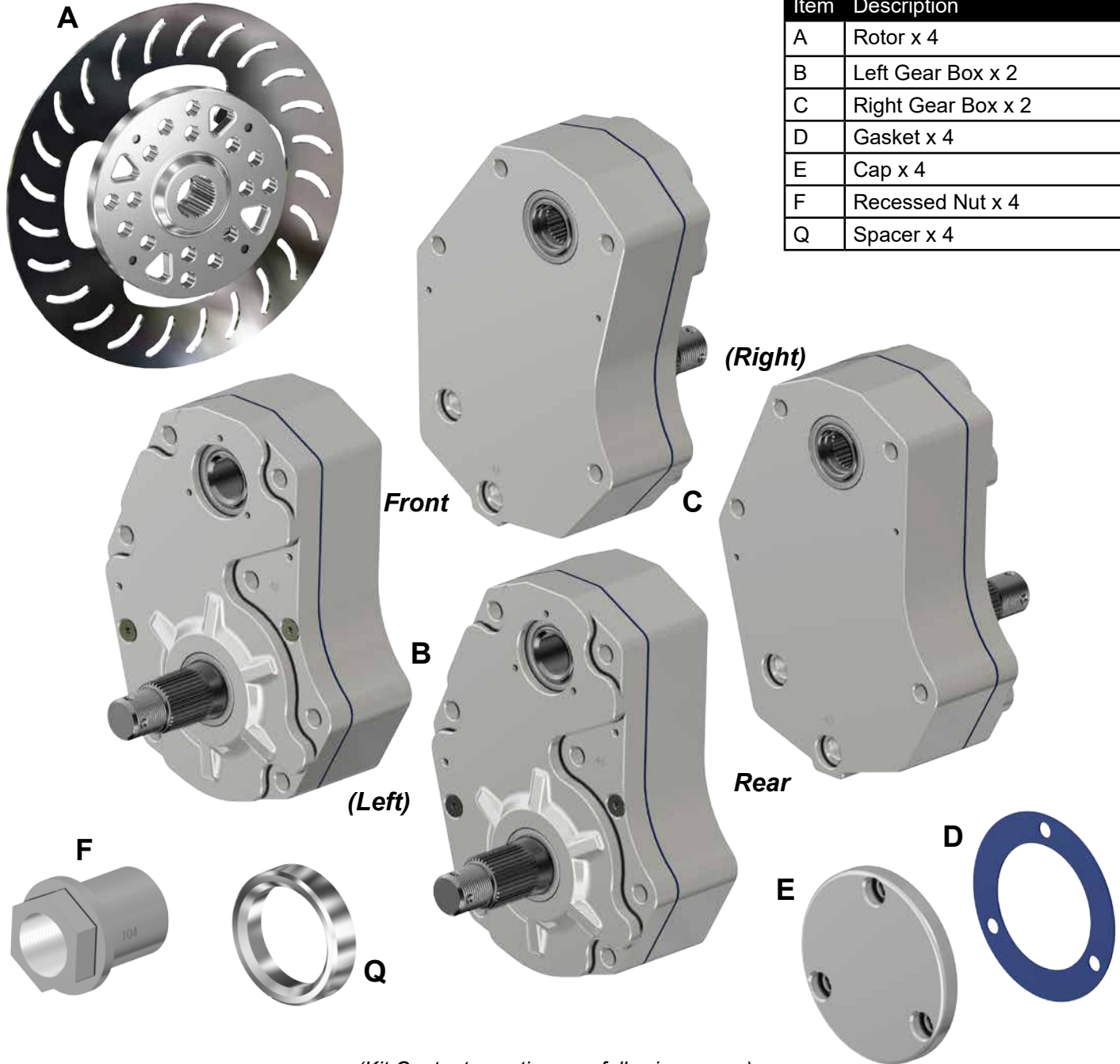

(Kit Contents continue on following pages)

WHEN FILLING GEAR BOX USE ONLY 80W-90 GEAR OIL. USING GREASE WILL CAUSE FAILURE OF GEARS AND BEARINGS. USING GREASE WILL VOID THE WARRANTY.

Need help with your installation?

✉ sales@superatv.com 🌐 www.superatv.com

☎ 1-855-743-3427 🕒 8:00am - 9:00pm EST M-Th
 8:00am - 7:00pm EST Friday
 9:00am - 2:00pm EST Saturday

Read instructions and view illustrations before beginning.

Thank You
 For Choosing
SUPERATV.COM[®]

Item	Description
G	Caliper Mounting Bracket x 4
H	Left Spindle
J	Right Spindle
K	Left Rear Plate
L	Right Rear Plate

(Kit Contents continued)

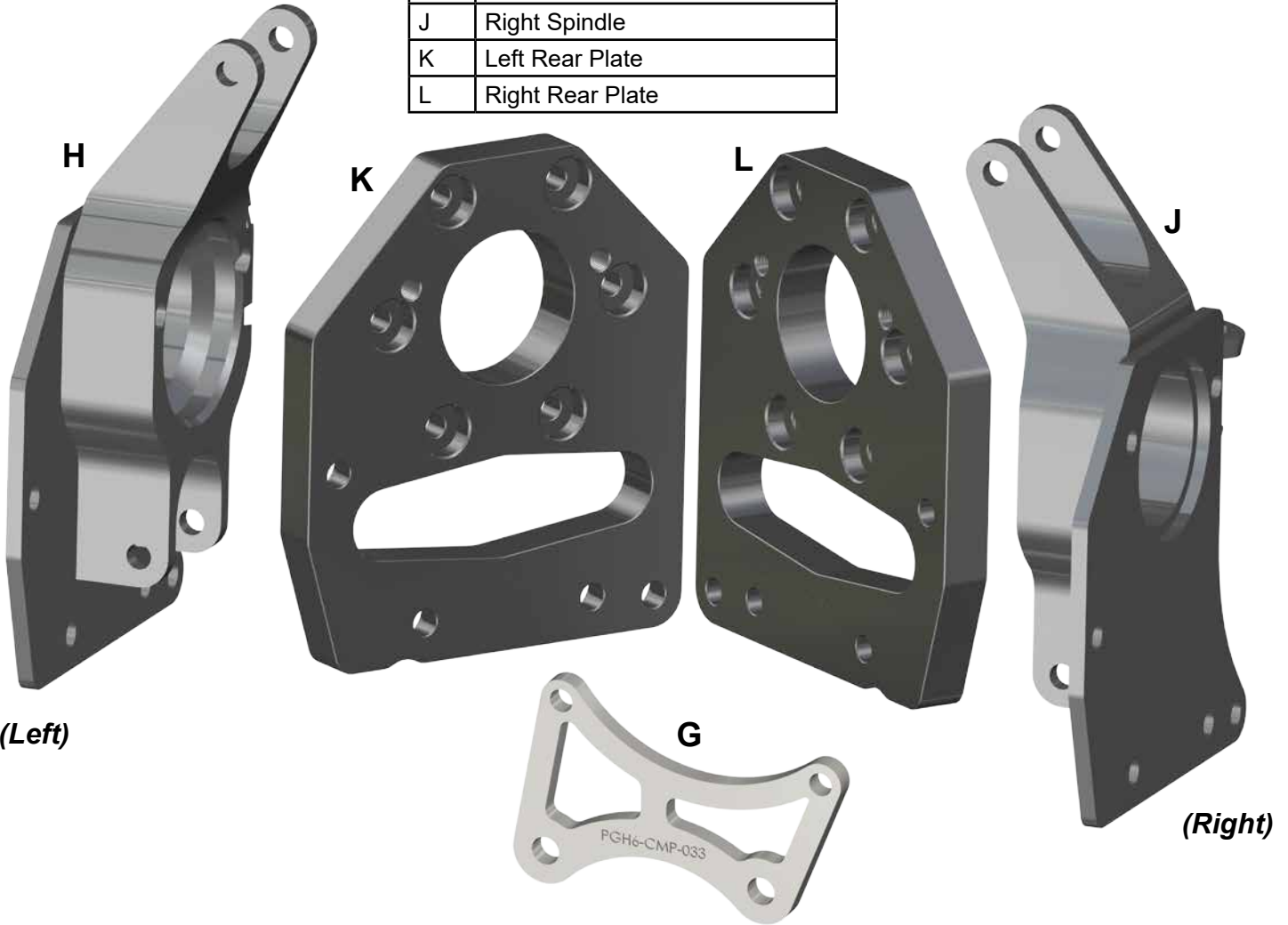

(Left)

(Right)

Brake Lines:

Length (approx)	Location
44"	Front x 2
32"	Front Supply
67"	Rear x 2
71"	Rear Supply



Fitting x 2



Brake Line Bracket



8x - Brake Line Clip

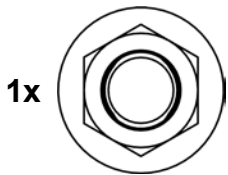

1x M10 Nylock Nut



2x M6 Nylock Nut

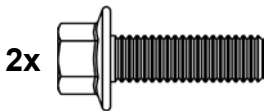

2x M6-1.0 x 20mm Lg. FHCS

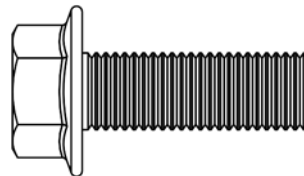

1x M10-1.50 x 30mm Lg. FHCS

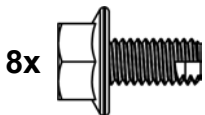

8x M6-1.0 x 12mm Lg. FHCS (self-tapping)

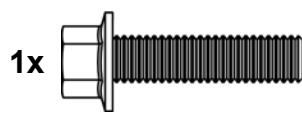

1x M6-1.0 x 25mm Lg. FHCS

Front Hardware Kit



Threadlock, 2mL

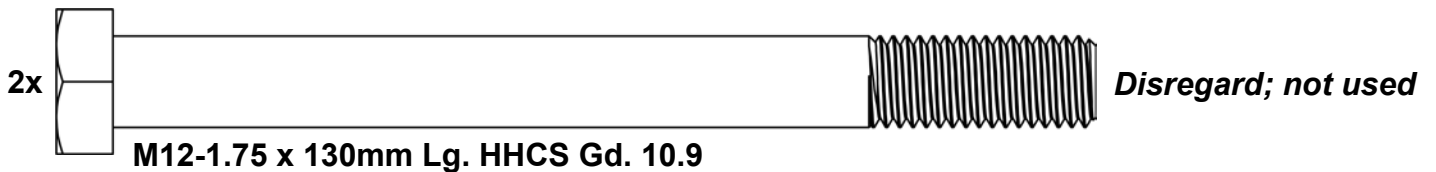
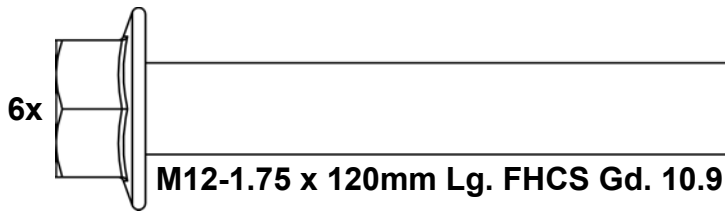
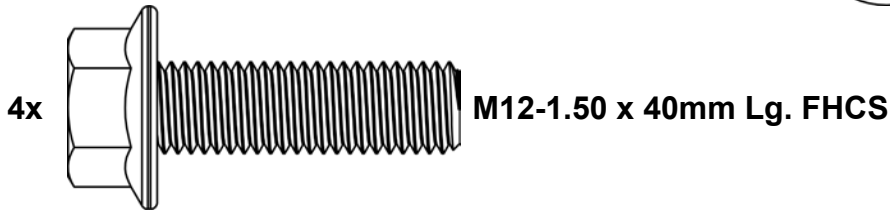
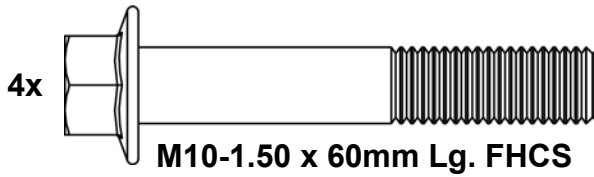
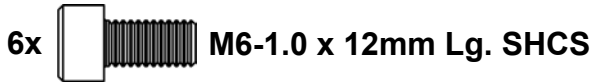
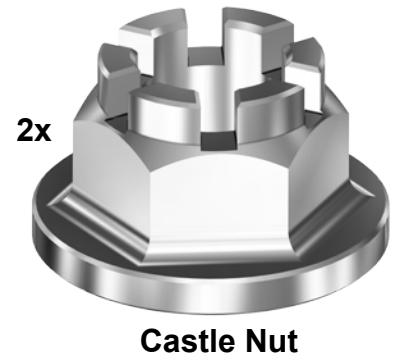

Machines with SuperATV Heavy Duty Tie Rod Ends must use provided hardware shown when securing to Steering Arms.



Rear Hardware Kit

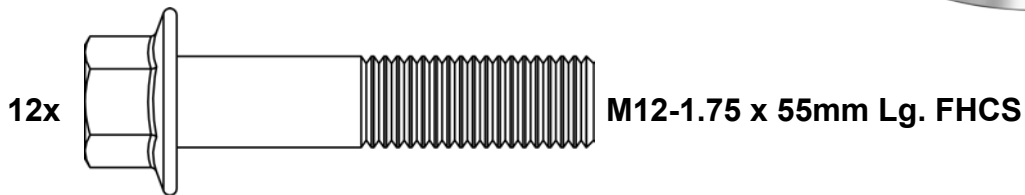
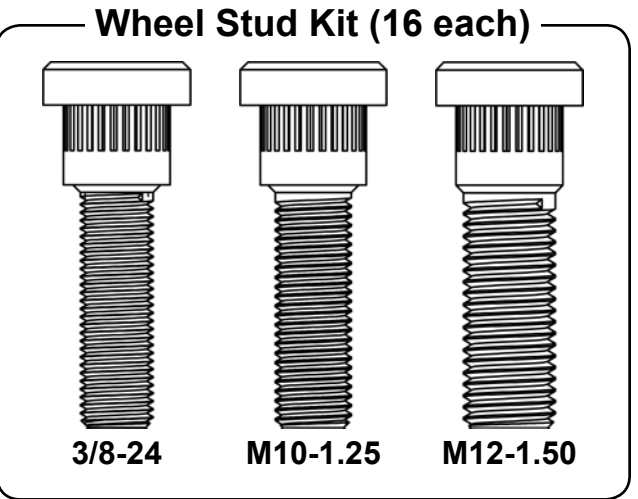
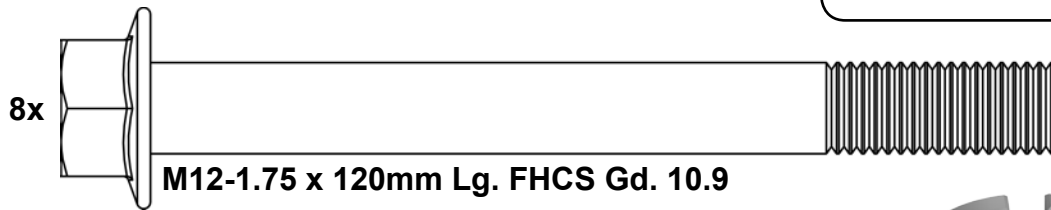
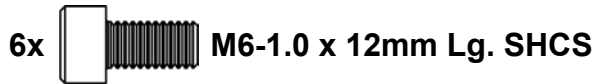

(Factory installed on billet models: disregard any remaining)

Accessory Hardware Kit

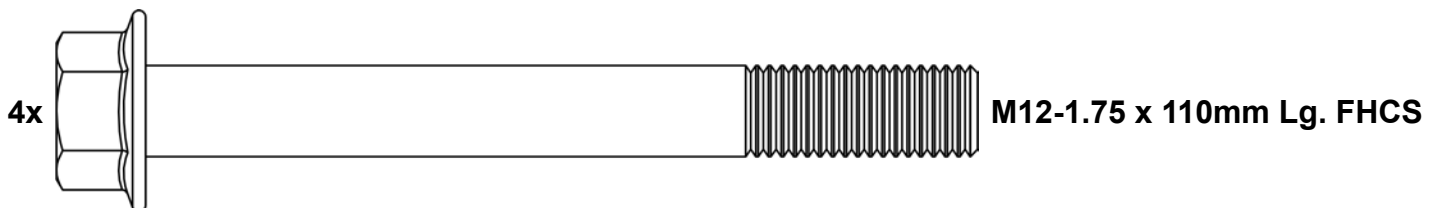
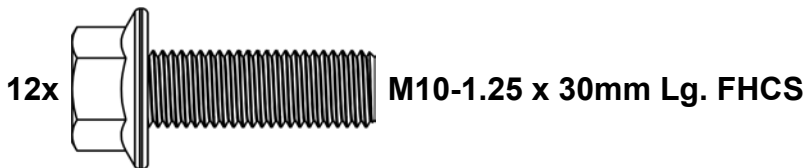

Read ALL instructions prior to operating Portal Gear Hubs. Injury to personnel, portal gear hub, and/or machine failure may be caused by improper installation, maintenance or operation.

- It is dangerous to get under a jacked-up vehicle. The vehicle could slip off the jack and fall on you. You could be crushed. Never place any part of your body under a vehicle that is on a jack. Never start or run the engine while the vehicle is on a jack. If you need to get under a raised vehicle, take it to a service center where it can be raised on a lift.
- Hot oil can cause severe burns. Use extreme care when removing lubrication plugs and when working close to a unit that has been in operation.
- Check lube level between scheduled lube changes to insure that proper lube level is maintained. Inspect the tightness of mounting bolts, excessive heating, or any unusual noise or vibration.
- Serious personal injury may occur as a result of improperly performed maintenance, adjustments or repairs.
- Always be extremely careful when working on the portal gear hub. Always follow commonly accepted safety practices and general common sense. Never risk personal injury.
- Do not operate the portal gear hub without proper lube and correct amount.

For safe operation and to maintain the unit warranty, when changing a provided fastener for any reason, it becomes the responsibility of the person making the change to properly account for fastener grade, thread engagement, load, tightening torque and the means of torque retention.

- Mounting bolts should be periodically checked to ensure that the unit is firmly anchored for proper operation.
- These instructions are not intended to cover all details or variations in equipment, nor provide for every possible contingency to be met in connection with selection, installation, operation, and maintenance.

Should further information be desired or should particular problems arise which are not covered sufficiently for the Buyer's purpose, the matter should be referred to SuperATV®.

In the event of the resale of any of the goods, in whatever form, Resellers/Buyers will include the following language in a conspicuous place and in a conspicuous manner in a written agreement covering such sale:

The manufacturer makes no warranties or representations, express or implied, by operation of law or otherwise, as to the merchantability or fitness for a particular purpose of the goods sold hereunder. Buyer acknowledges that it alone has determined that the goods purchased hereunder will suitably meet the requirements of their intended use. In no event will the manufacturer be liable for consequential, incidental or other damages. Even if the repair or replacement remedy shall be deemed to have failed of its essential purpose under Section 2-719 of the Uniform Commercial Code, the manufacturer shall have no liability to Buyer for consequential damages.

Resellers/Buyers agree to also include this entire document including the danger, warnings and cautions above in a conspicuous place and in a conspicuous manner in writing to instruct users on the safe usage of the product.

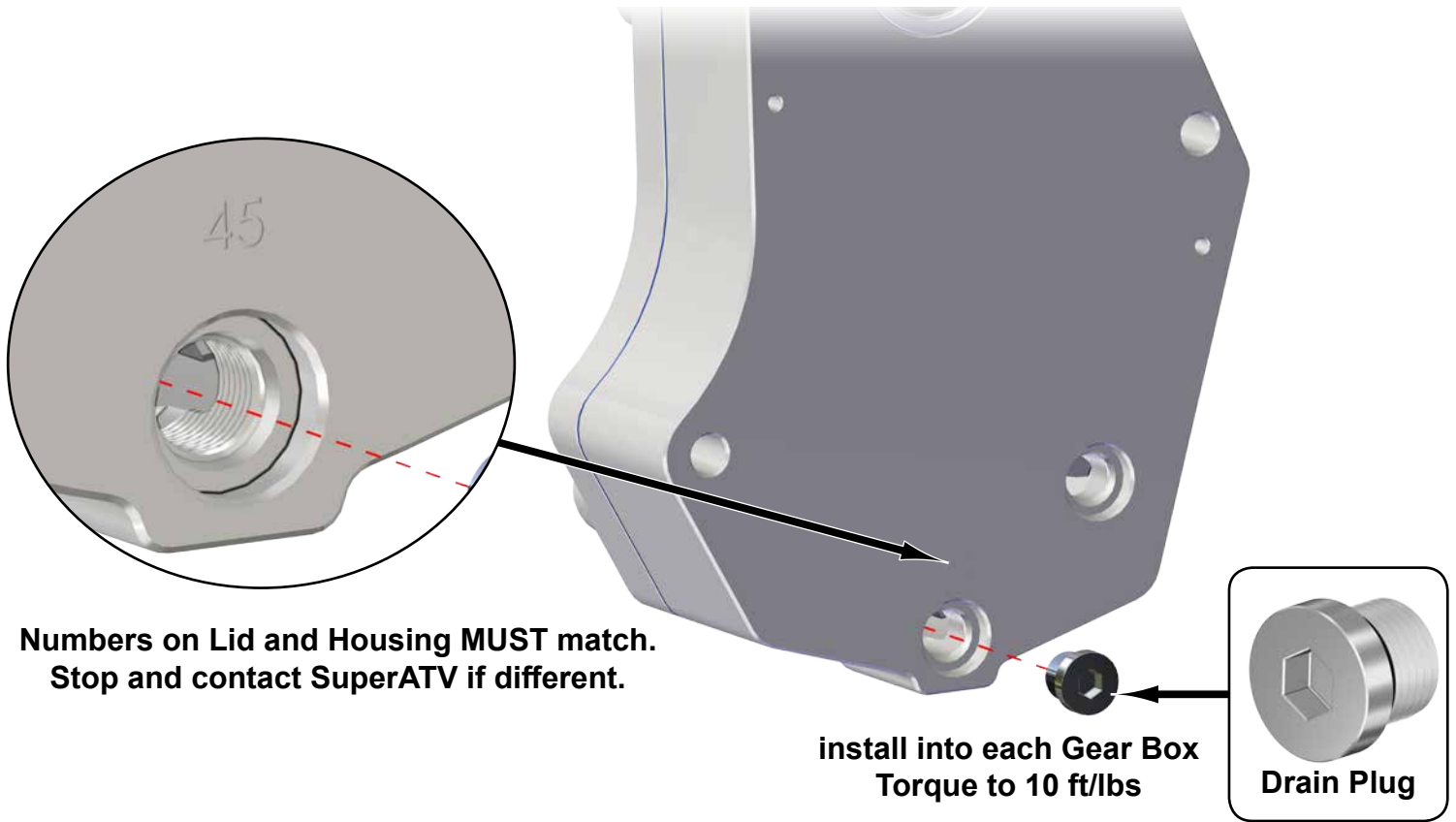

DO NOT USE IMPACT WRENCH WHEN INSTALLING ANY HARDWARE INTO HOUSING

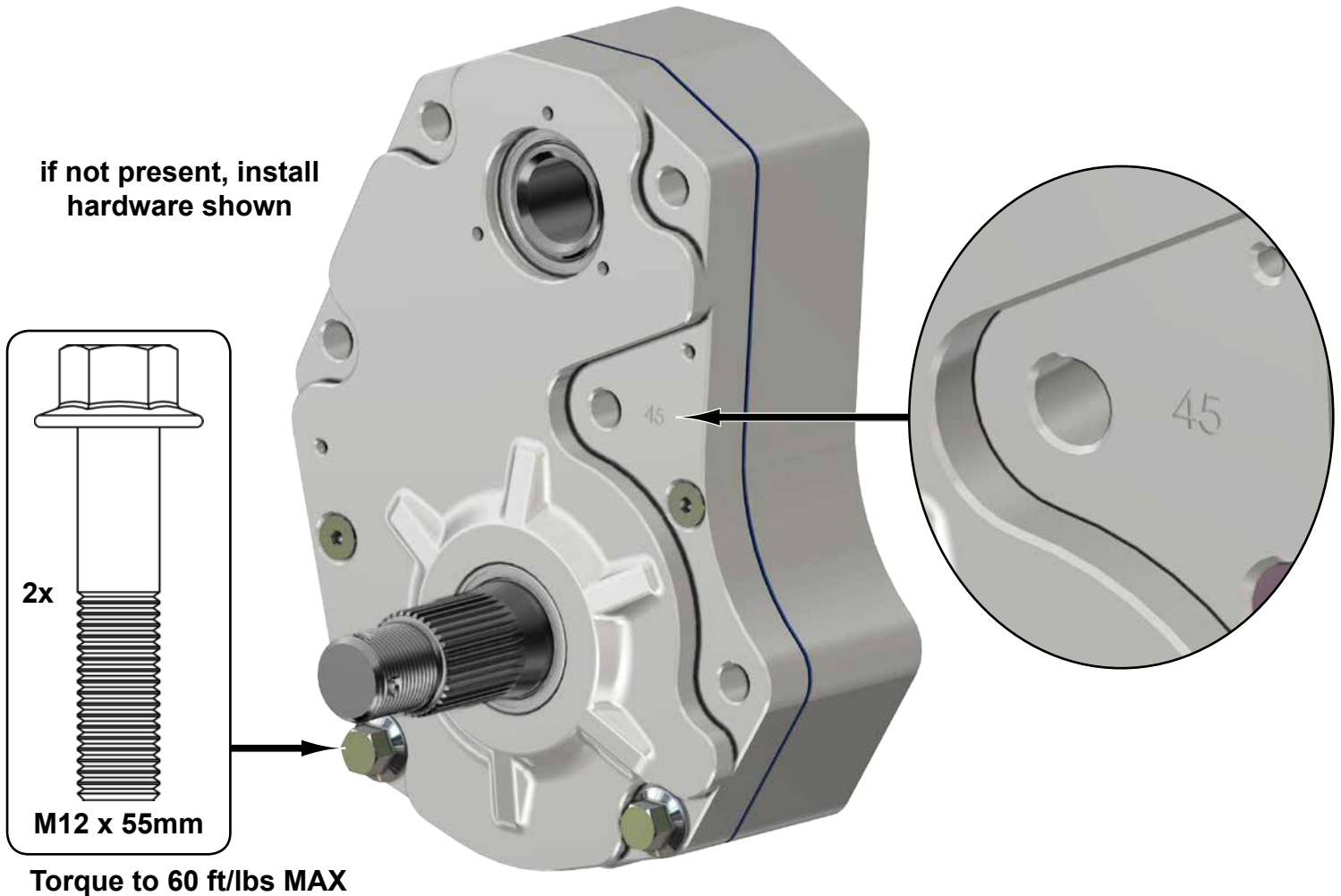

Install provided Studs into Rotors (A):

- See "Wheel Hub Bolt Patterns".
- Note machines bolt pattern and lug size.
- Set Rotors (A) aside when complete.

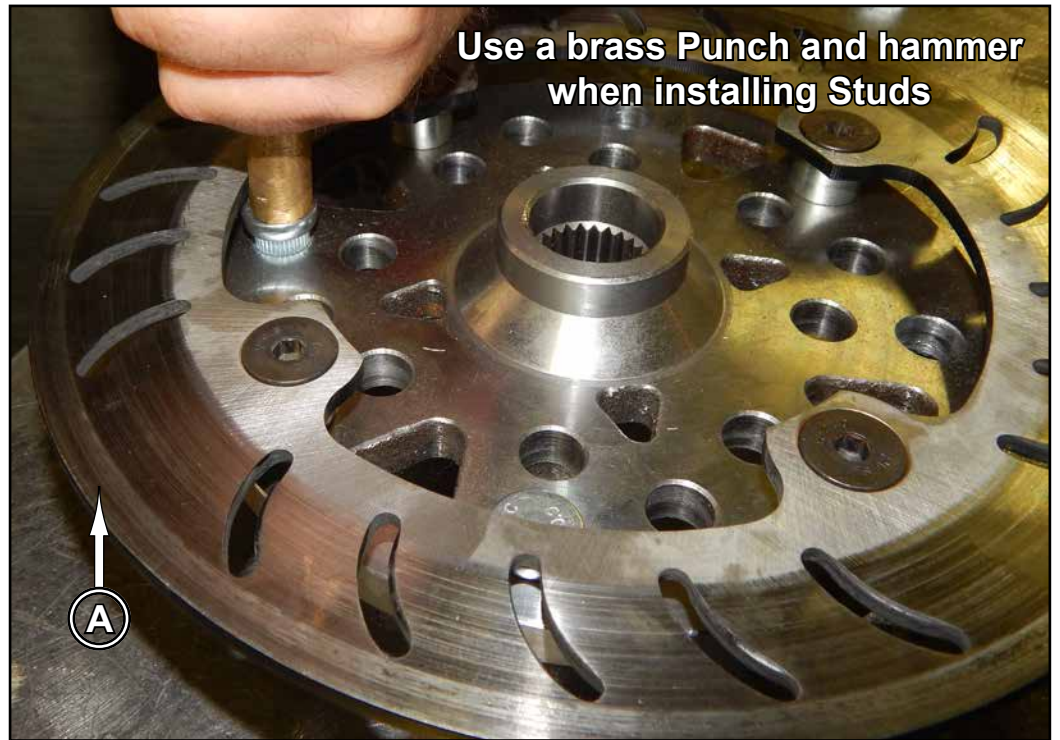

Use a brass Punch and hammer when installing Studs



Use spacers of some sort when installing Studs.

Sockets work well as spacers

Wheel Hub Bolt Patterns

- A - - - -
- B - - - -
- C - - - -
- D - - - -

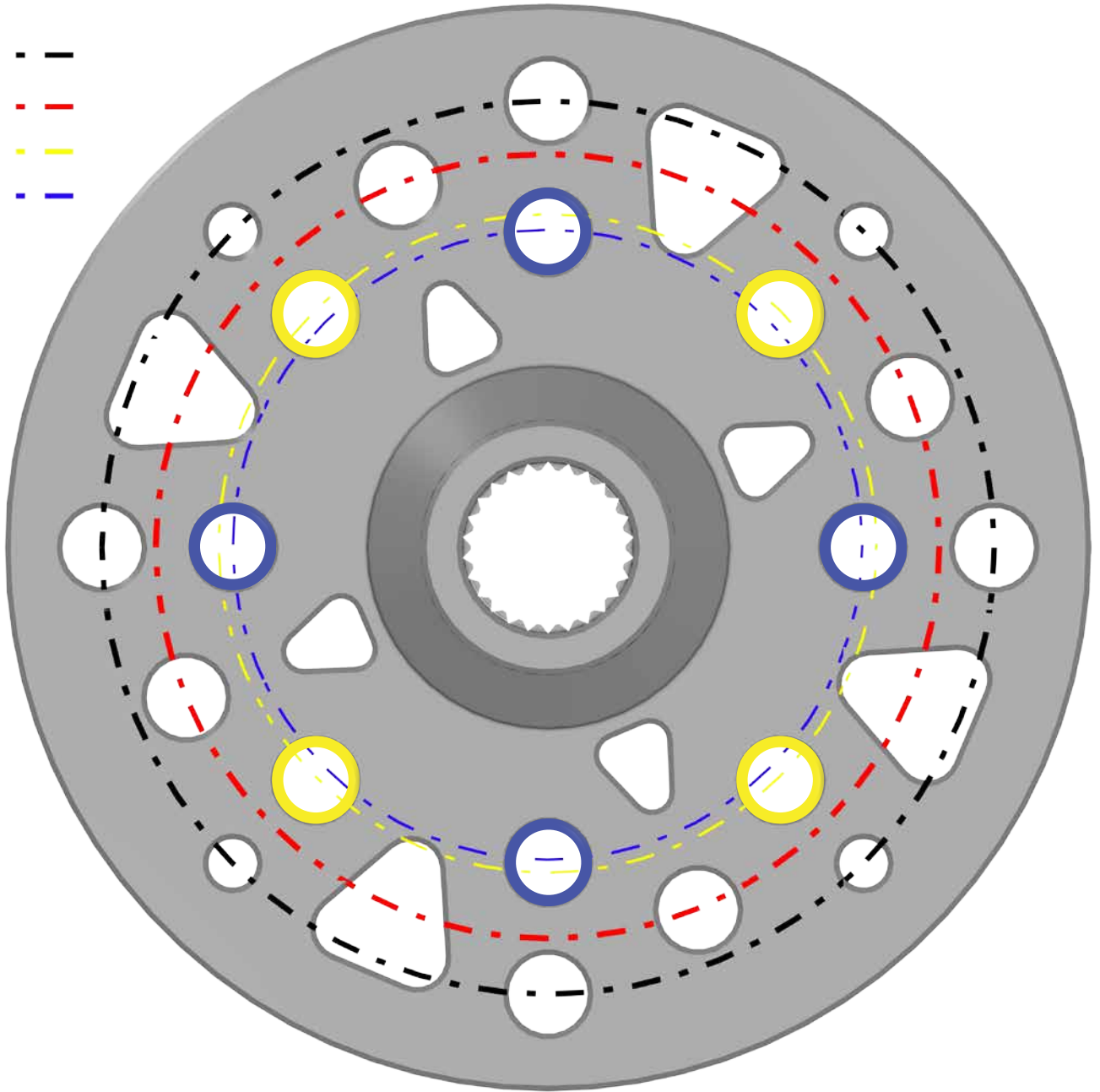

Pattern	Machine	Diameter
A	Polaris	156mm
B	Can-Am/Teryx4	137mm
C	Arctic Cat/ Textron	115mm
D	Honda/Yamaha	110mm

Front Components Removal: *Keep all components removed from machine.*

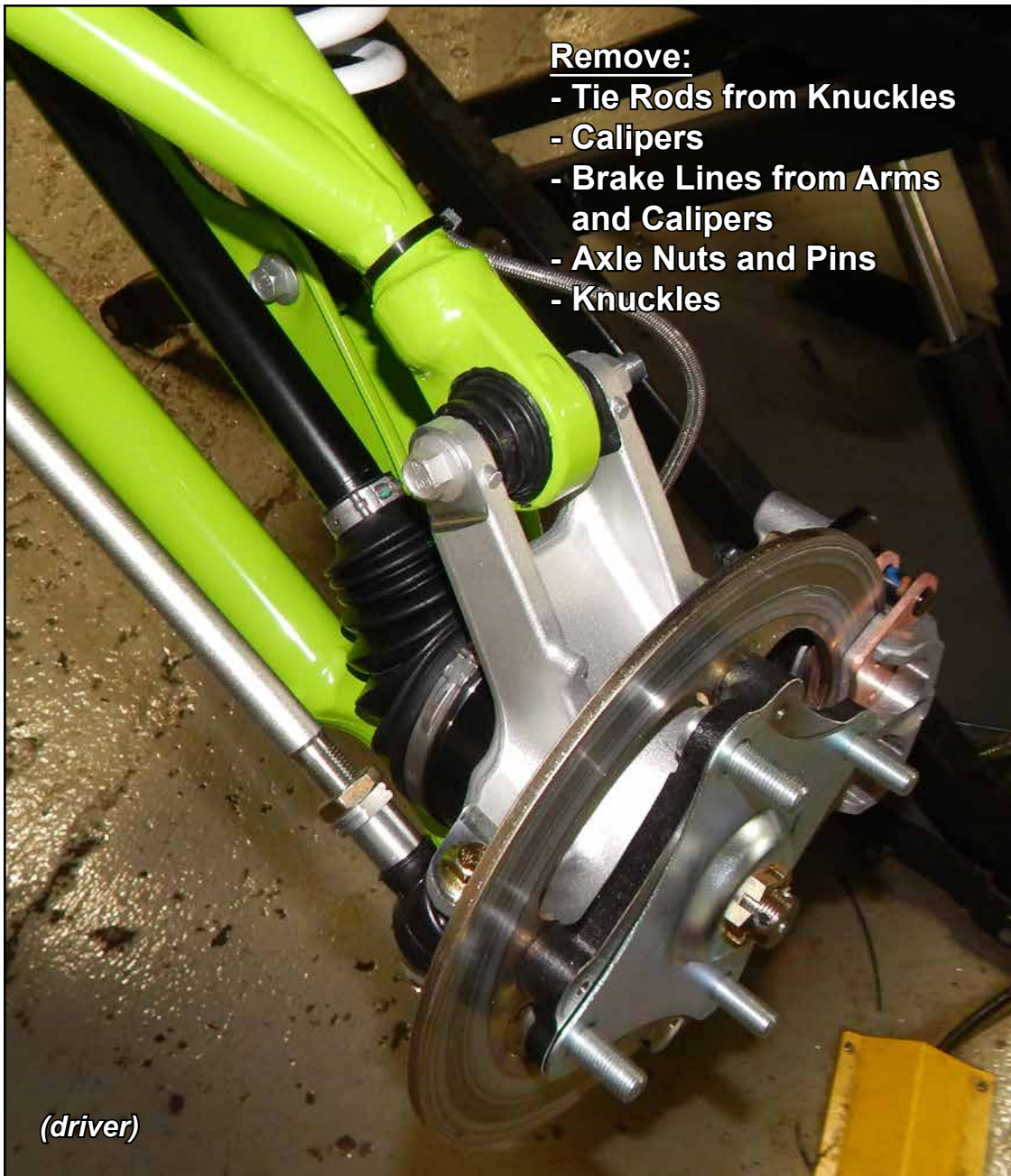

Rear Components Removal: *Keep all components removed from machine.*

Remove:

- Calipers
- Brake Lines from Arms and Calipers
- Axle Nuts and Pins
- Bearings

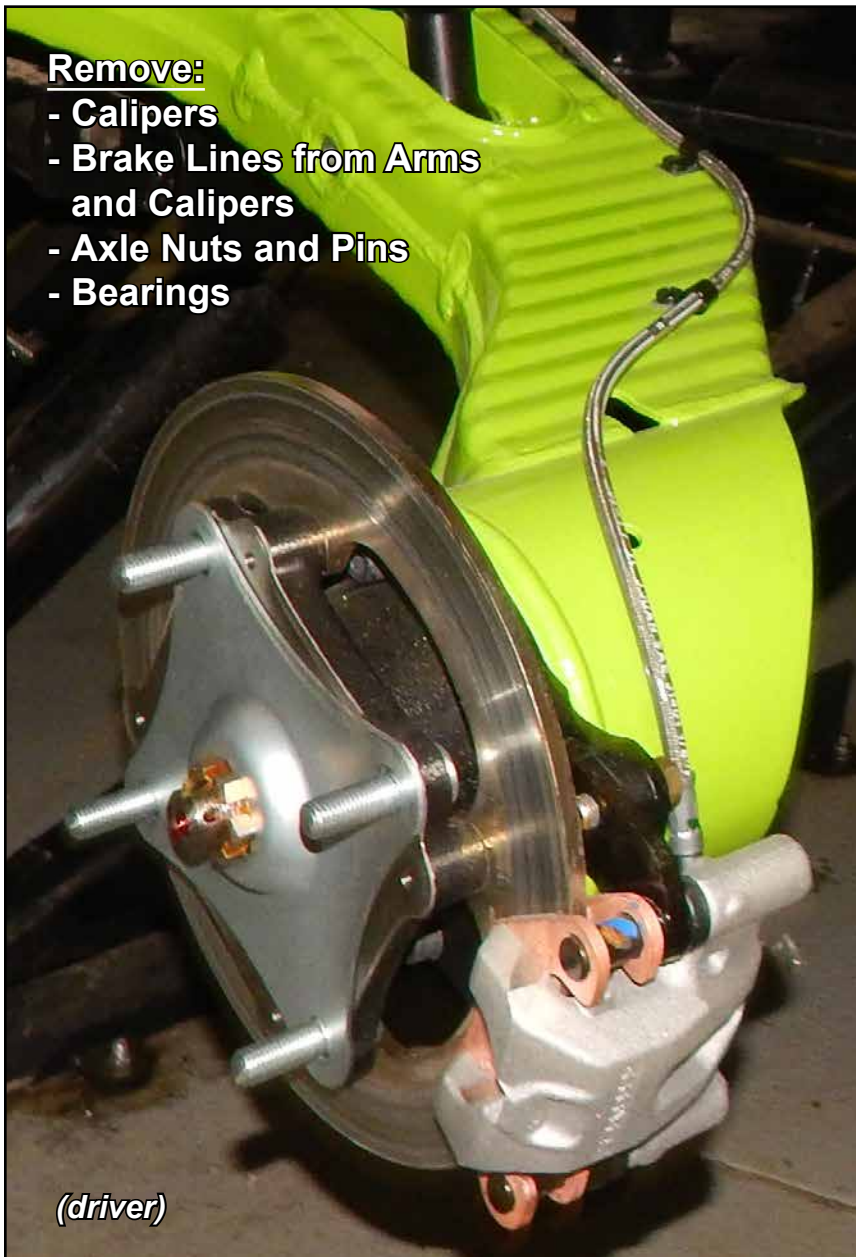

(driver)

Remove:

- driver side Shock



- Remove:**
- Sway Bar

(passenger)

Brake Lines Removal:

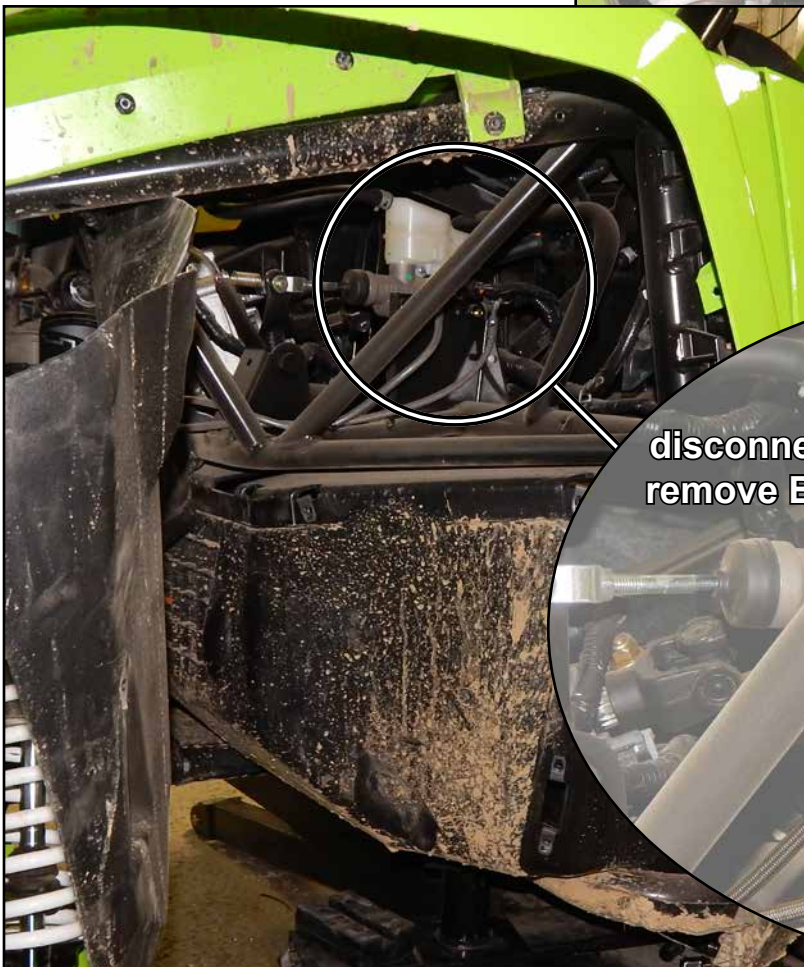

Rear Brake Lines Removal:

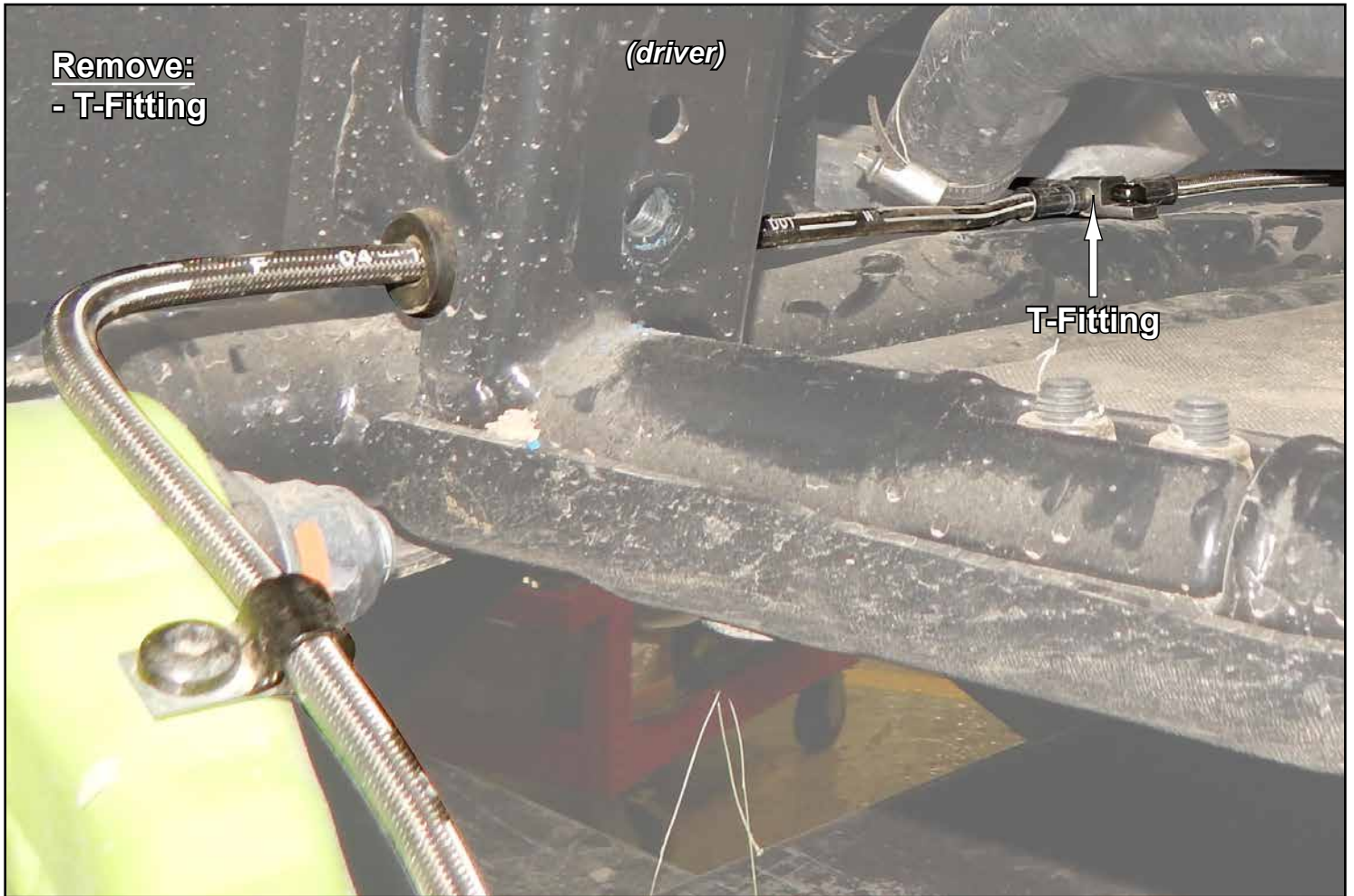

- Pull Supply Line, T-Fitting, and Brake Lines out of machine.

Front Brake Lines Removal:

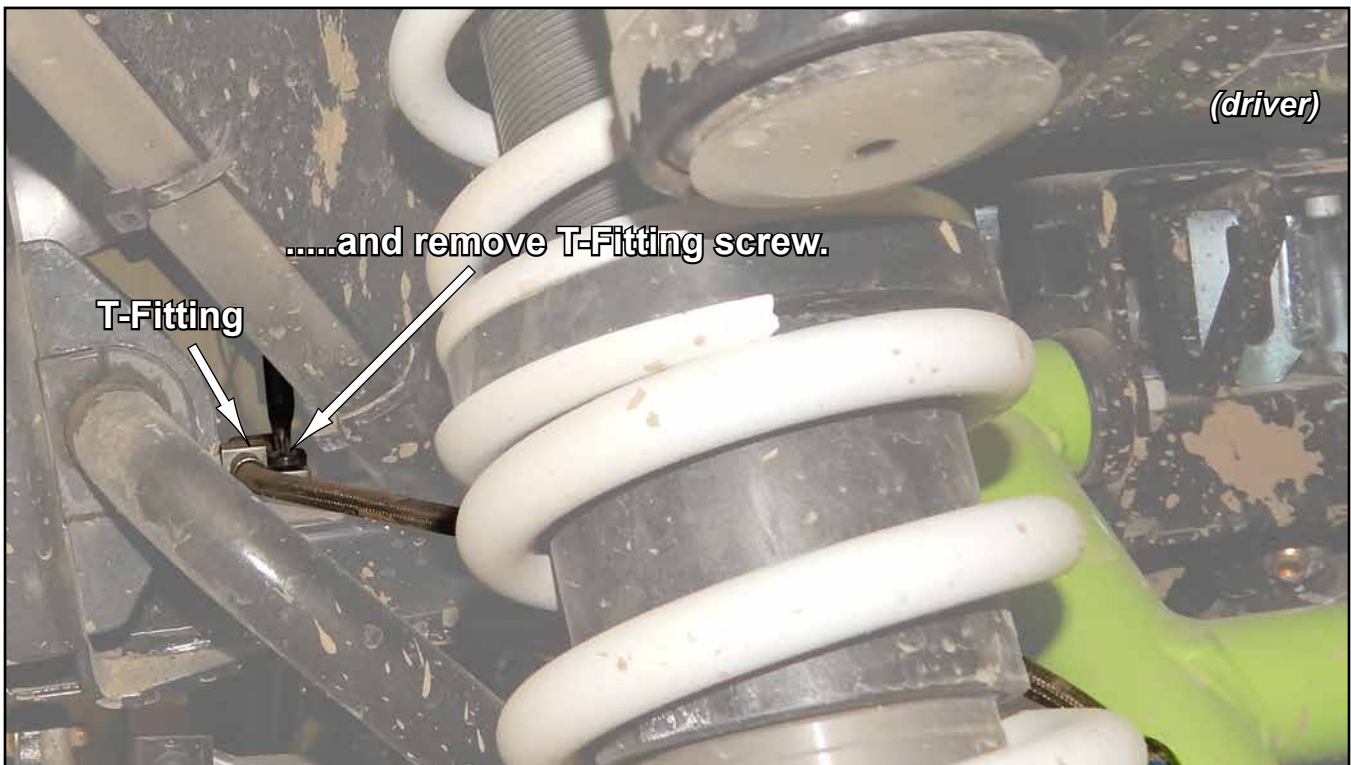

- Pull Supply Line, T-Fitting, and Brake Lines out of machine.

Front: *do not tighten hardware completely unless noted.*

- Secure Right Spindle (J) to A-Arms with stock hardware.
- Secure Tie Rod End to Right Spindle (J) with stock hardware.
- Install Spacer (Q) onto Axle.

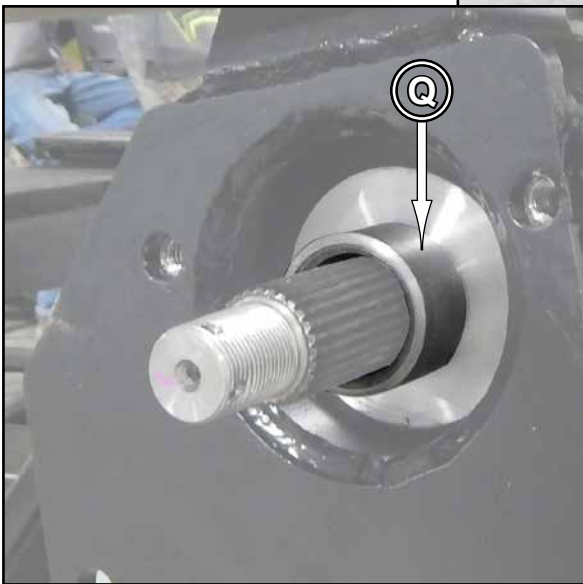
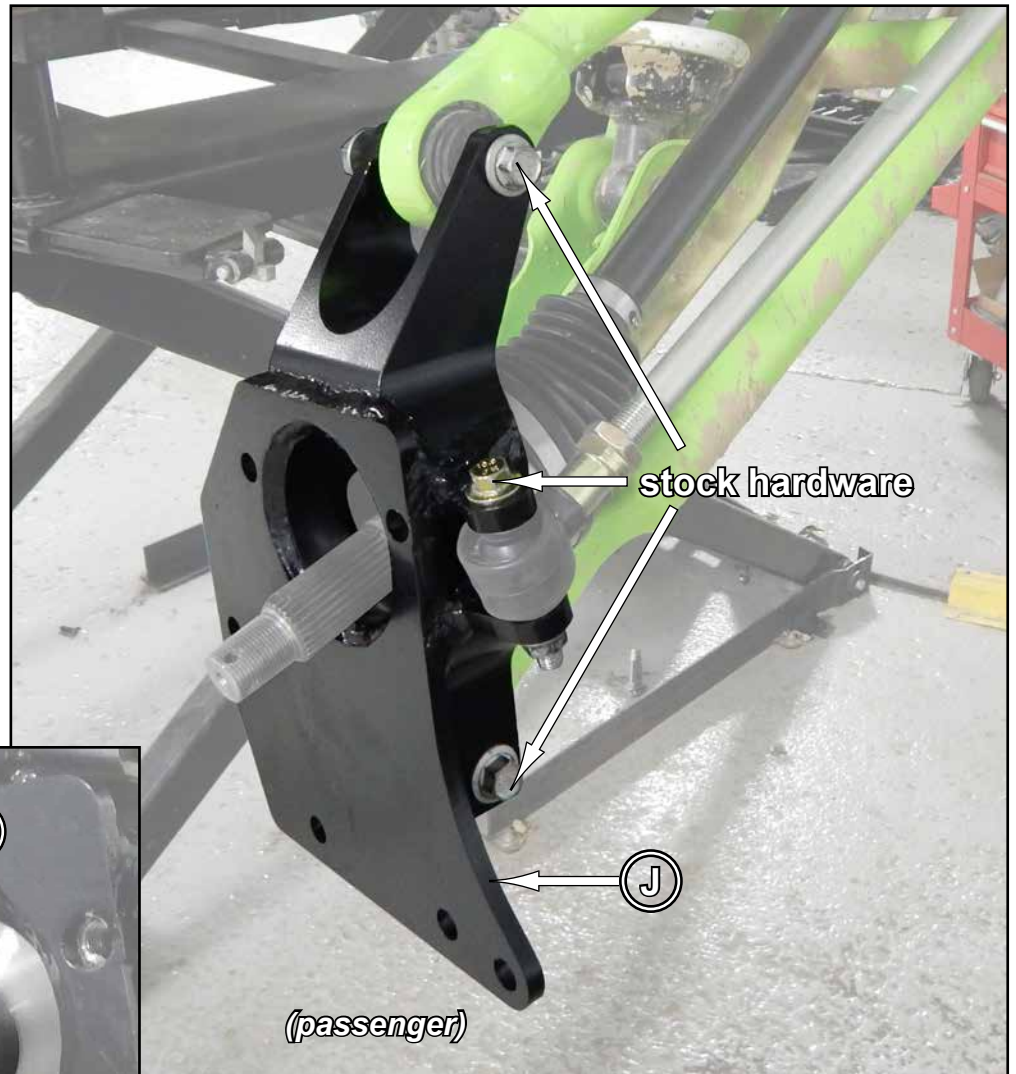

STOP If machine has SuperATV Heavy Duty Tie Rod Ends see page 3 for correct hardware.

Tighten hardware completely and repeat steps for opposite side.

Front continued:

- Secure Right Gear Box (C) and Caliper Mounting Bracket (G) to Right Spindle (J) with hardware shown.
- Secure stock Axle with Recessed Nut (F); use thread locker.

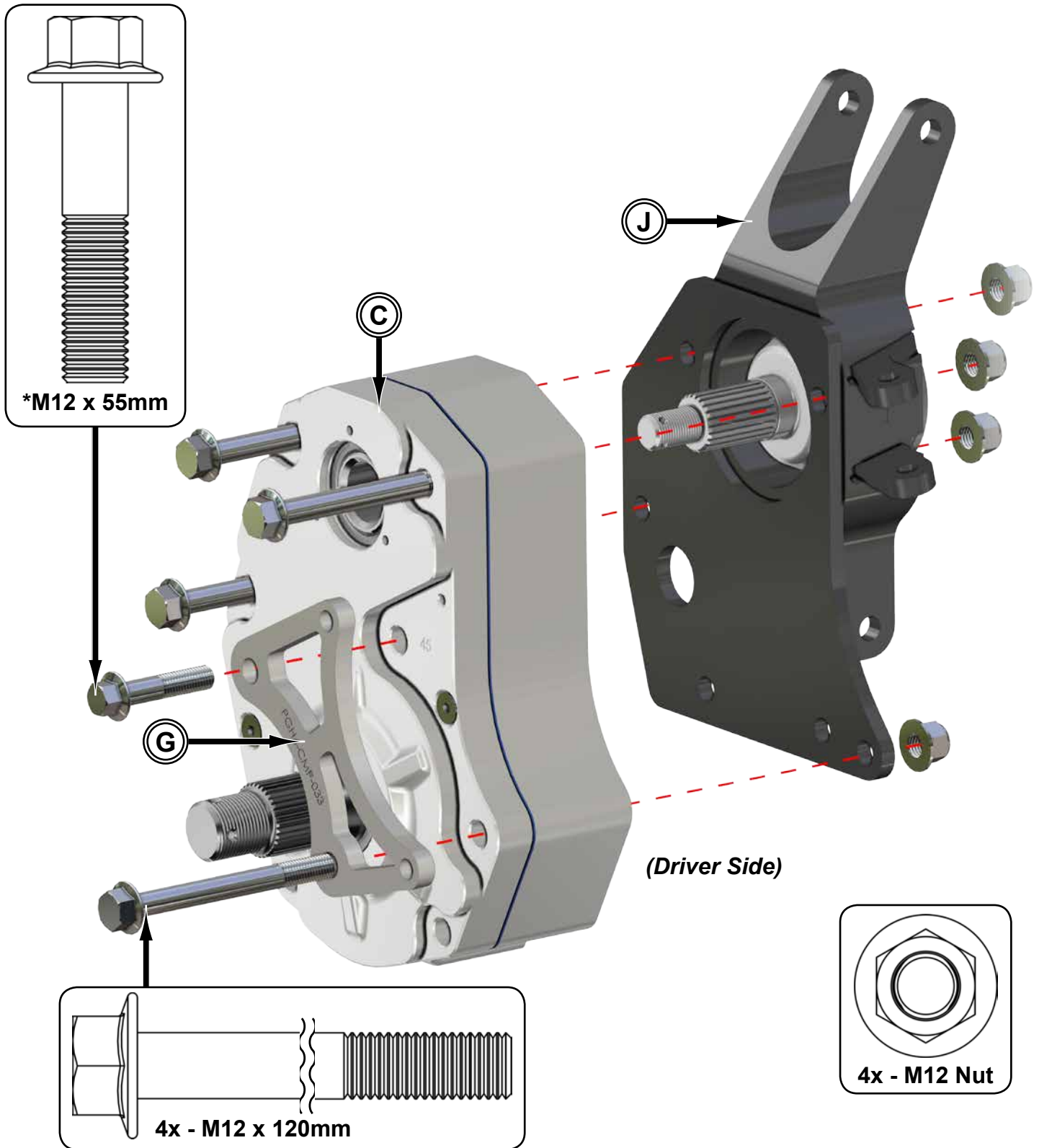

*Torque to 60 ft/lbs MAX

Tighten hardware completely and repeat steps for opposite side.

Front continued:

- Secure stock Axle with Recessed Nut (F); use thread locker.
- Secure Gasket (D) and Cap (E) to Gear Box with hardware shown.
- Secure Rotor (A) to Gear Box Axle Shaft with hardware shown.



- Torque to minimum 300 Ft/Lbs.
- Continue tightening until Cotter Pin can be installed.

Tighten all hardware completely and repeat steps for opposite side.

Front continued:

- Reinstall Brake Calipers to Caliper Mounts (G) with stock hardware.

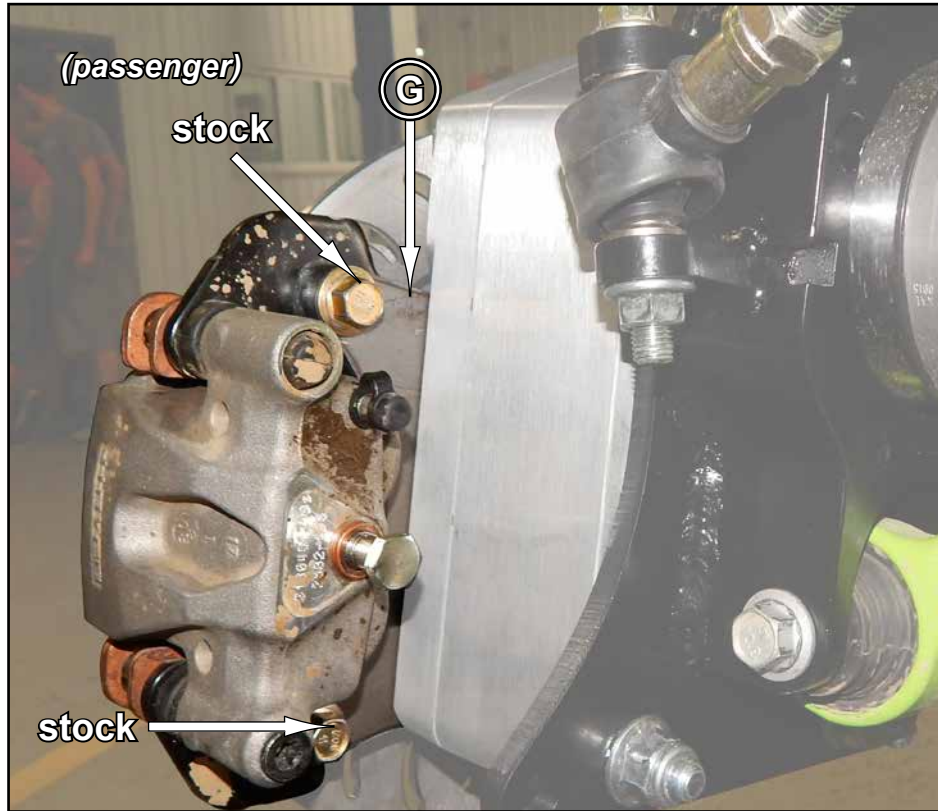

Tighten hardware completely and repeat steps for opposite side.

Front Brake Lines:

- Install provided Fitting to stock location with provided M6 x 25mm FHCS.
- Connect Brake Lines.
- Follow stock routing when installing.
- Secure to A-Arms with provided Brake Line Clips and M6 self-tapping hardware.
- Ensure no binding or interference can occur when in use.

Rear: *do not tighten hardware completely unless noted.*

- Install Left Rear Plate (K) to machine with hardware shown. Use thread locker on hardware.
- Tighten hardware completely and repeat for opposite side.



Rear continued:

- Install Left Gear Box (B) to Left Rear Plate (K) with hardware shown.
- Secure Caliper Mounting Bracket (G) to Gear Box and Left Rear Plate with hardware shown.

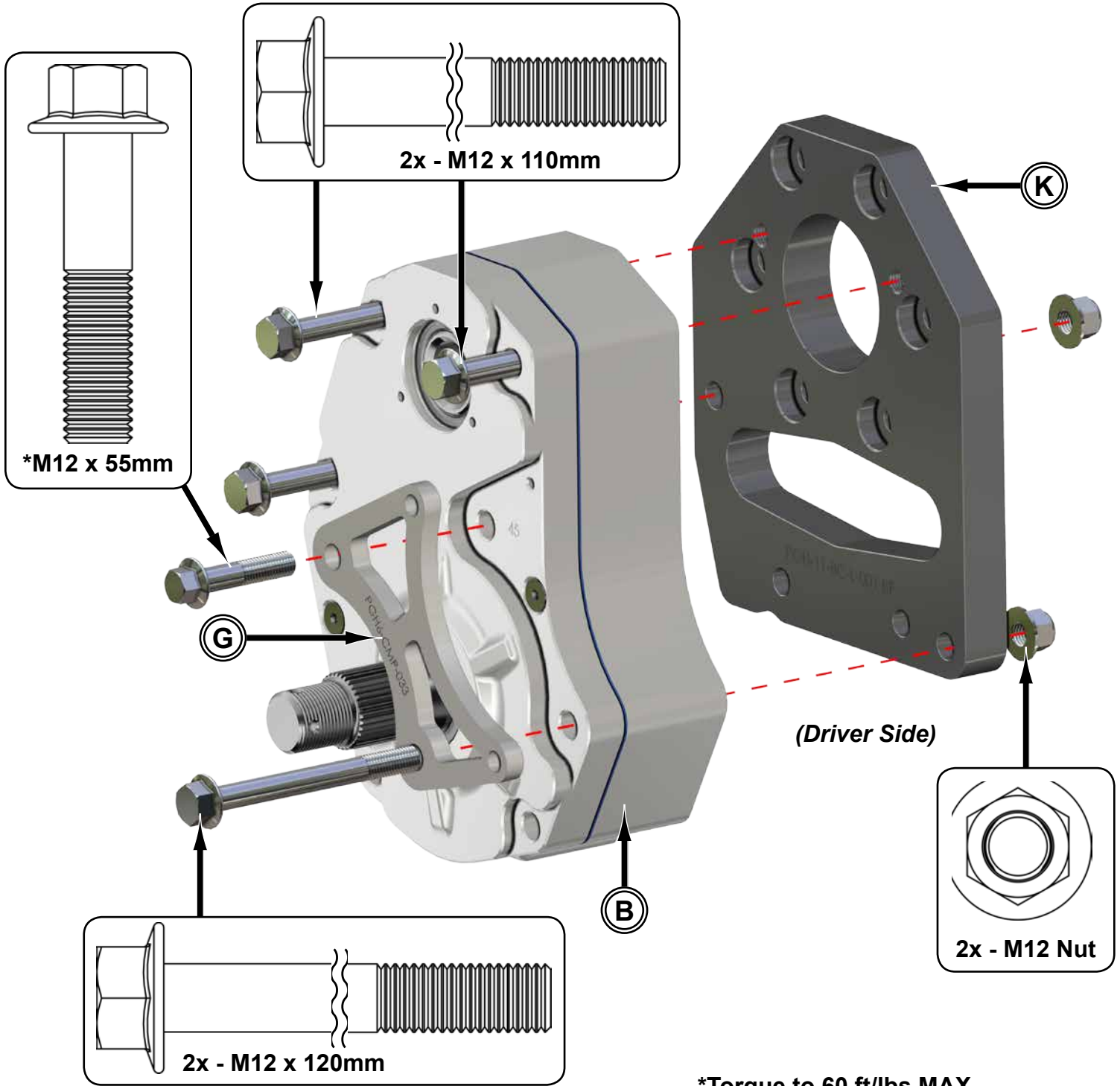

Tighten hardware completely and repeat steps for opposite side.

Rear continued:

- Secure stock Axle with Recessed Nut (F); use thread locker.
- Secure Gasket (D) and Cap (E) to Right Gear Box (C) with hardware shown.

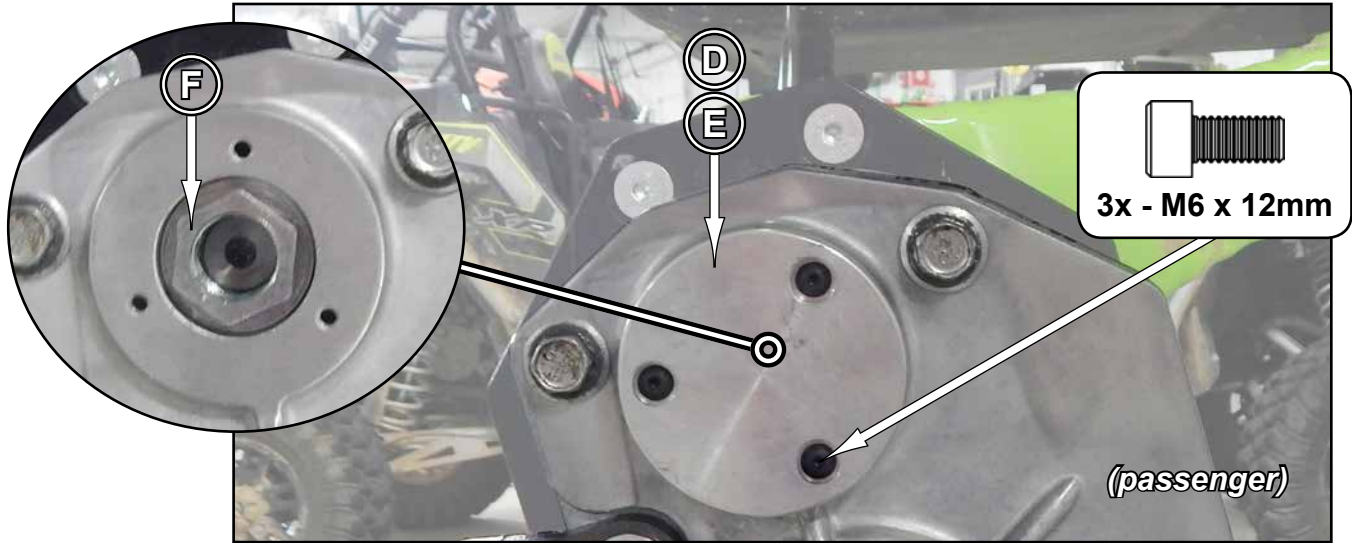

- Reinstall Brake Calipers to Caliper Mounts (G) with stock hardware.
- Secure Rotor (A) to Gear Box Axle Shaft with hardware shown.

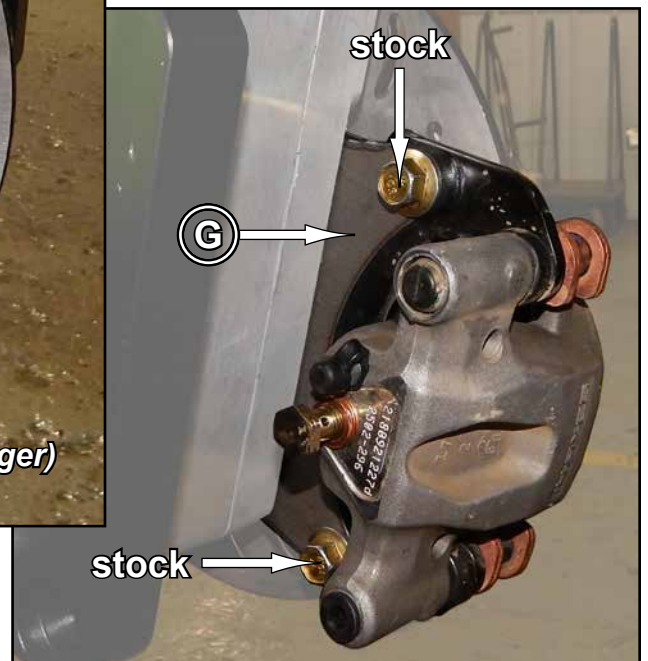

- Torque to minimum 300 Ft/Lbs.
- Continue tightening until Cotter Pin can be installed.

Tighten hardware completely and repeat steps for opposite side.

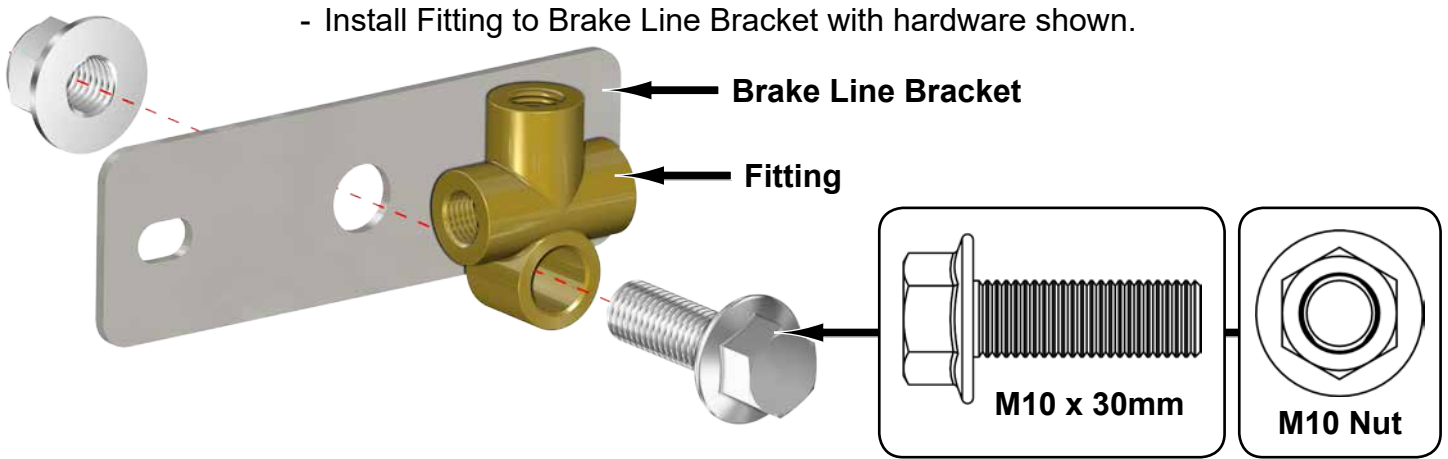

- Install Brake Line Bracket to Frame with hardware shown. Connect Brake Lines.
- Follow stock routing when installing.
- Secure to Trailing Arms with provided Brake Line Clips and M6 self-tapping hardware.
- Ensure no binding or interference can occur when in use.

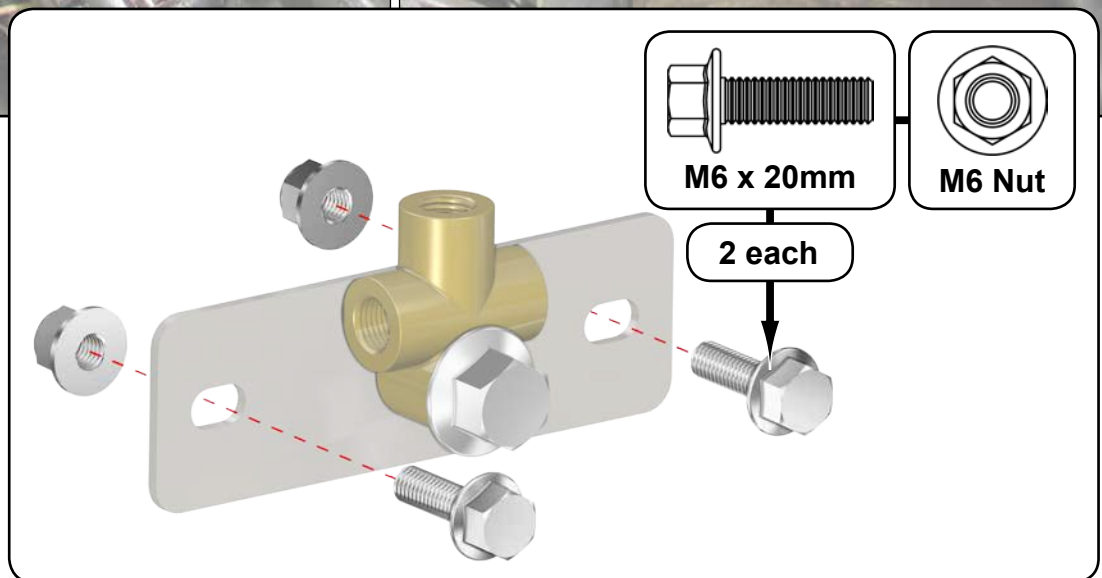
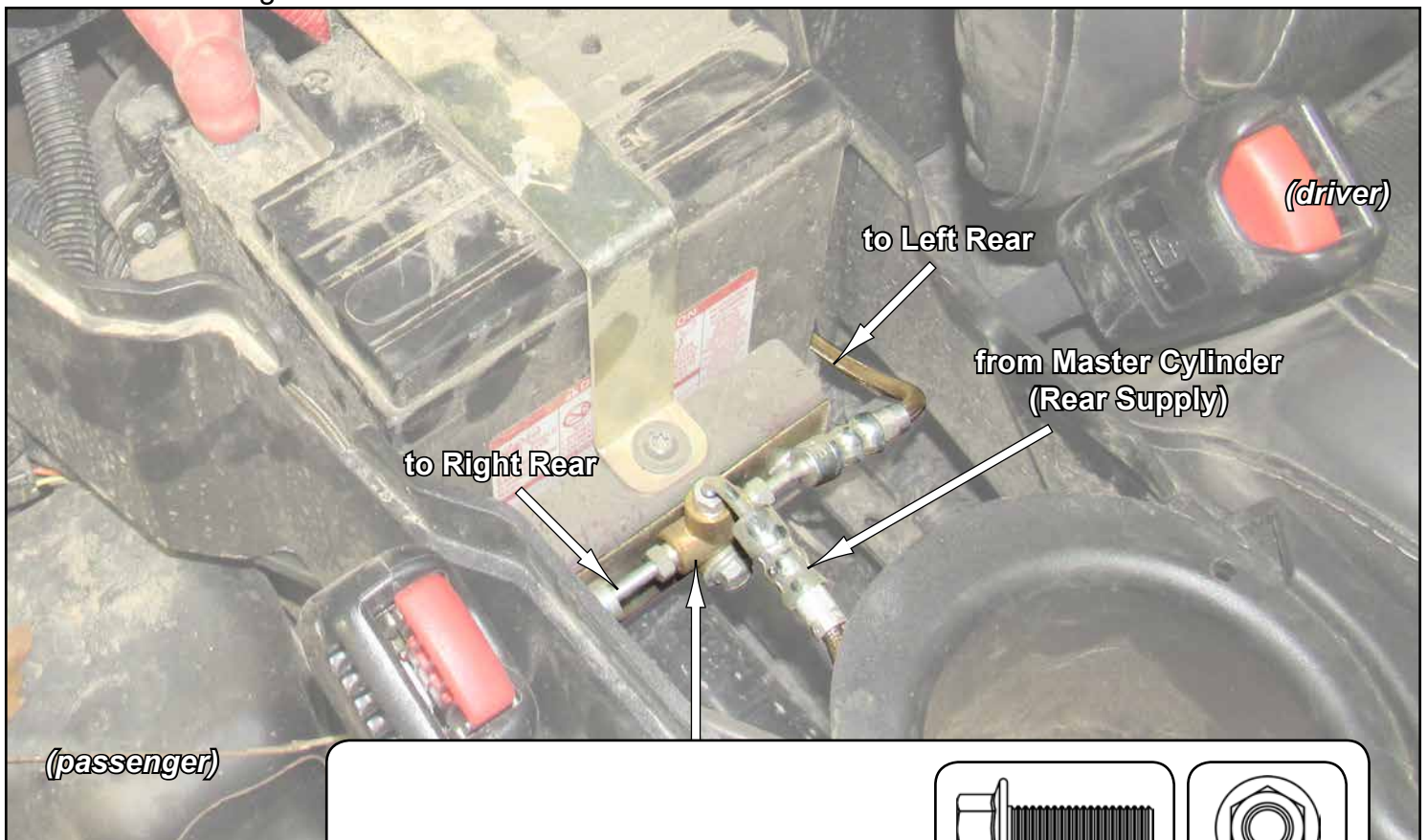

- Attach a hose to a funnel and fill each Gear Box (B-C) with 80W-90 Gear Oil.
- Fill up to fill hole.
- Install Drain Plug.

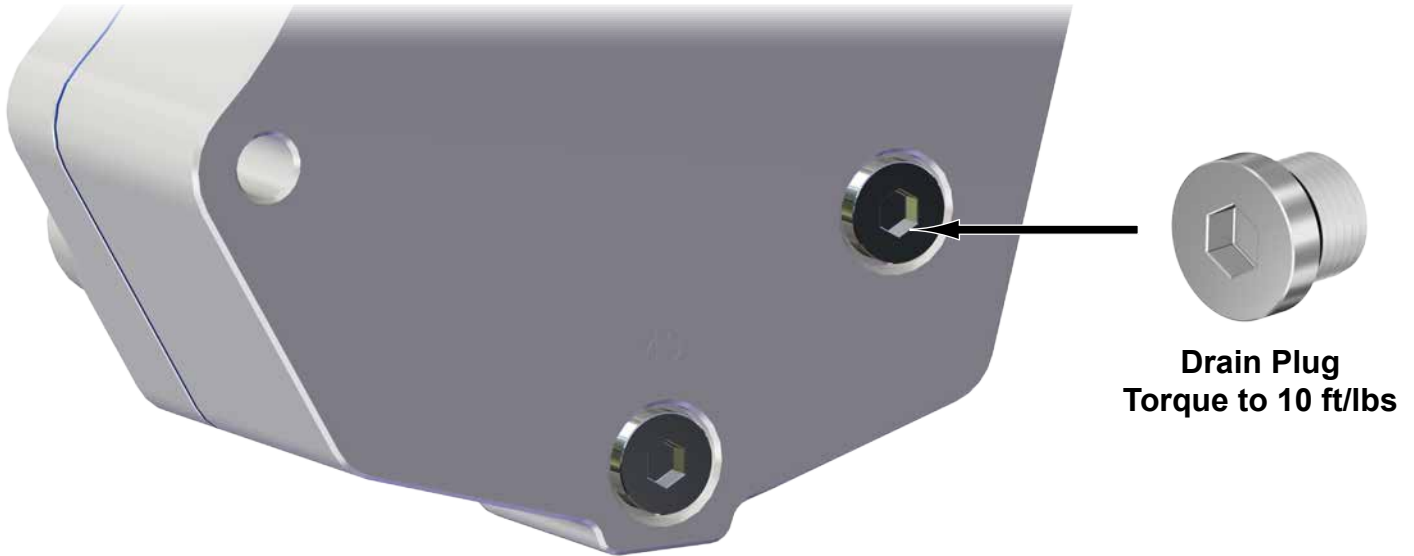

Liability Statement

SuperATV's® products are designed to best fit user's ATV/UTV under stock conditions. Adding, modifying, or fabricating any factory or aftermarket parts will void any warranty provided by SuperATV® and is not recommended. SuperATV's® products could interfere with other aftermarket accessories. If user has aftermarket products on machine, contact SuperATV® to verify that they will work together.

Although SuperATV® has thousands of satisfied customers, user should be aware that installing lift kits, long travel, or suspension kits, tires, etc. will change the ride of machine and may increase maintenance and part wear. Operating any off-road machine while, or after, consuming alcohol and/or drugs increases risk of bodily harm or death. No warranty or representation is made as to this product's ability to protect user from severe injury or death. SuperATV® urges operators and occupants to wear a helmet and appropriate riding gear at all times.

By purchasing and installing SuperATV® products, user agrees that should damages occur, SuperATV® will not be held responsible for loss of time, use, labor fees, replacement parts, or freight charges. SuperATV®, nor any 3rd party, will not be held responsible for any direct, indirect, incidental, special, or consequential damages that result from any product purchased from SuperATV®. The total liability of seller to user for all damages, losses, and causes of action, if any, shall not exceed the total purchase price paid for the product that gave rise to the claim.

SuperATV® will warranty only parts provided by SuperATV®. Any damage or problems with OEM housings, bearings, seals, or other manufacturers' products will not be covered by SuperATV®. SuperATV® parts and products are not warranted if item was not installed properly, misused, or modified.

Installing, adding, modifying, or fabricating any factory or aftermarket product to your ATV/UTV may violate certain local, state, and federal laws. Be advised that laws vary depending on town, city, county, state, etc. Use of certain products on public streets, roads, or highways may be in violation law. The Buyer is solely and exclusively legally and personally responsible for any violation of the law by the installation or use of the product. You must abide by all local, state, and federal laws, including but not limited to vehicle safety, traffic laws, and ordinances. It is your responsibility to know the laws and how they apply to you.

The Buyer is responsible to fully understand the capability and limitations of his/her vehicle according to manufacturer specifications, warnings and instructions and agrees to hold SuperATV® harmless from any damage resulting from failure to adhere to such specifications, warnings and/ or instructions. The Buyer is also responsible to obey all applicable federal, state, and local laws and ordinances when operating his/her vehicle while using this product, and the Buyer agrees to hold SuperATV® harmless from any violation thereof.