

**Carrier Bearing**

(installation performed on Polaris RZR XP<sup>®</sup> Turbo)

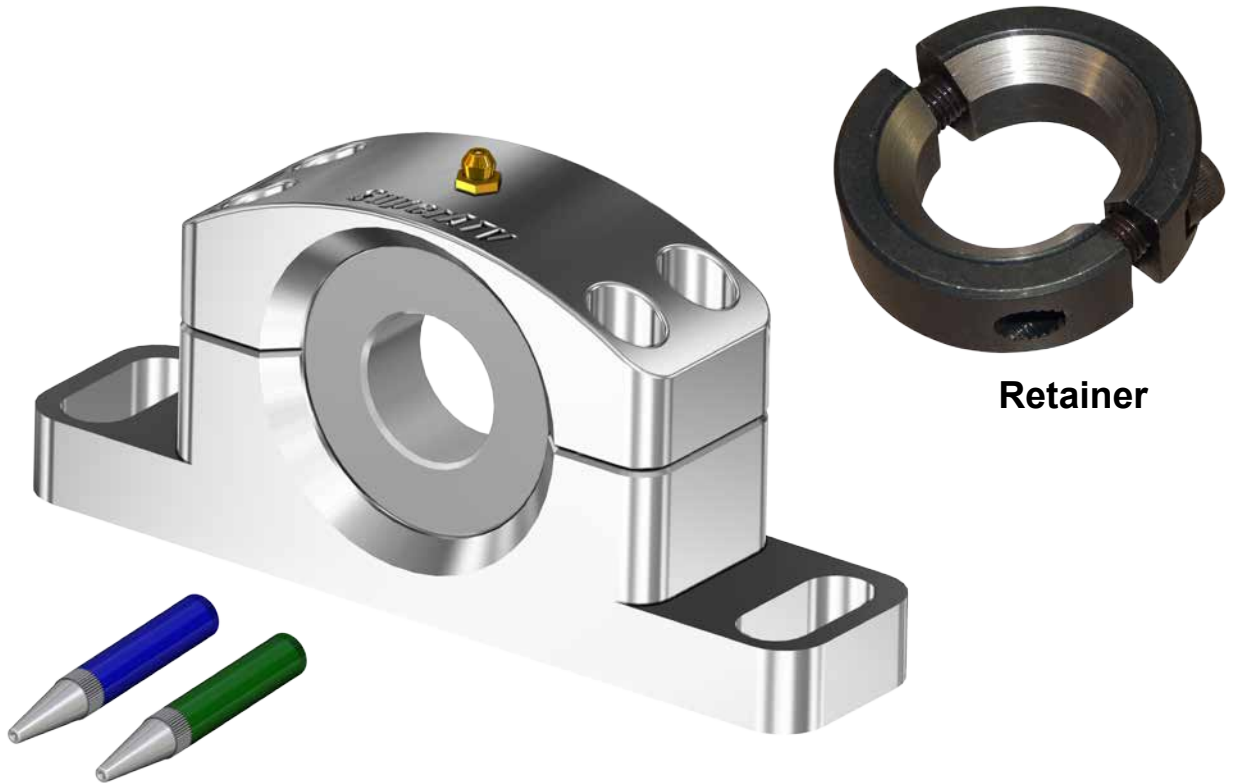

**Retainer**

**Liability Statement**

SuperATV's<sup>®</sup> products are designed to best fit user's ATV/UTV under stock conditions. Adding, modifying, or fabricating any factory or aftermarket parts will void any warranty provided by SuperATV<sup>®</sup> and is not recommended. SuperATV's<sup>®</sup> products could interfere with other aftermarket accessories. If user has aftermarket products on machine, contact SuperATV<sup>®</sup> to verify that they will work together.

Although SuperATV<sup>®</sup> has thousands of satisfied customers, user should be aware that installing lift kits, long travel, or suspension kits, tires, etc. will change the ride of machine and may increase maintenance and part wear. Operating any off-road machine while, or after, consuming alcohol and/or drugs increases risk of bodily harm or death. No warranty or representation is made as to this product's ability to protect user from severe injury or death. SuperATV<sup>®</sup> urges operators and occupants to wear a helmet and appropriate riding gear at all times.

By purchasing and installing SuperATV<sup>®</sup> products, user agrees that should damages occur, SuperATV<sup>®</sup> will not be held responsible for loss of time, use, labor fees, replacement parts, or freight charges. SuperATV<sup>®</sup>, nor any 3rd party, will not be held responsible for any direct, indirect, incidental, special, or consequential damages that result from any product purchased from SuperATV<sup>®</sup>. The total liability of seller to user for all damages, losses, and causes of action, if any, shall not exceed the total purchase price paid for the product that gave rise to the claim.

SuperATV<sup>®</sup> will warranty only parts provided by SuperATV<sup>®</sup>. Any damage or problems with OEM housings, bearings, seals, or other manufacturers' products will not be covered by SuperATV<sup>®</sup>. SuperATV<sup>®</sup> parts and products are not warranted if item was not installed properly, misused, or modified.

Installing, adding, modifying, or fabricating any factory or aftermarket product to your ATV/UTV may violate certain local, state, and federal laws. Be advised that laws vary depending on town, city, county, state, etc. Use of certain products on public streets, roads, or highways may be in violation law. The Buyer is solely and exclusively legally and personally responsible for any violation of the law by the installation or use of the product. You must abide by all local, state, and federal laws, including but not limited to vehicle safety, traffic laws, and ordinances. It is your responsibility to know the laws and how they apply to you.

The Buyer is responsible to fully understand the capability and limitations of his/her vehicle according to manufacturer specifications, warnings and instructions and agrees to hold SuperATV<sup>®</sup> harmless from any damage resulting from failure to adhere to such specifications, warnings and/ or instructions. The Buyer is also responsible to obey all applicable federal, state, and local laws and ordinances when operating his/her vehicle while using this product, and the Buyer agrees to hold SuperATV<sup>®</sup> harmless from any violation thereof.

**Need help with your installation?**



sales@superatv.com



www.superatv.com



1-855-743-3427



8:00am - 9:00pm EST M-Th  
8:00am - 7:00pm EST Friday  
9:00am - 2:00pm EST Saturday

**Read instructions and view illustrations before beginning.**

*Thank You*

*For Choosing*



- Carrier Bearing on Turbo Models must be accessed through top of machine; **see pages 2 - 5.**
- Carrier Bearing on General and non-Turbo models can be accessed from under machine; **see page 7.**

*Keep all components removed from machine.*

- Remove components listed and shown.

Following components already removed and not shown:

- Seats
- Shifter Knob and Boot
- Seat Belt Boots
- Console

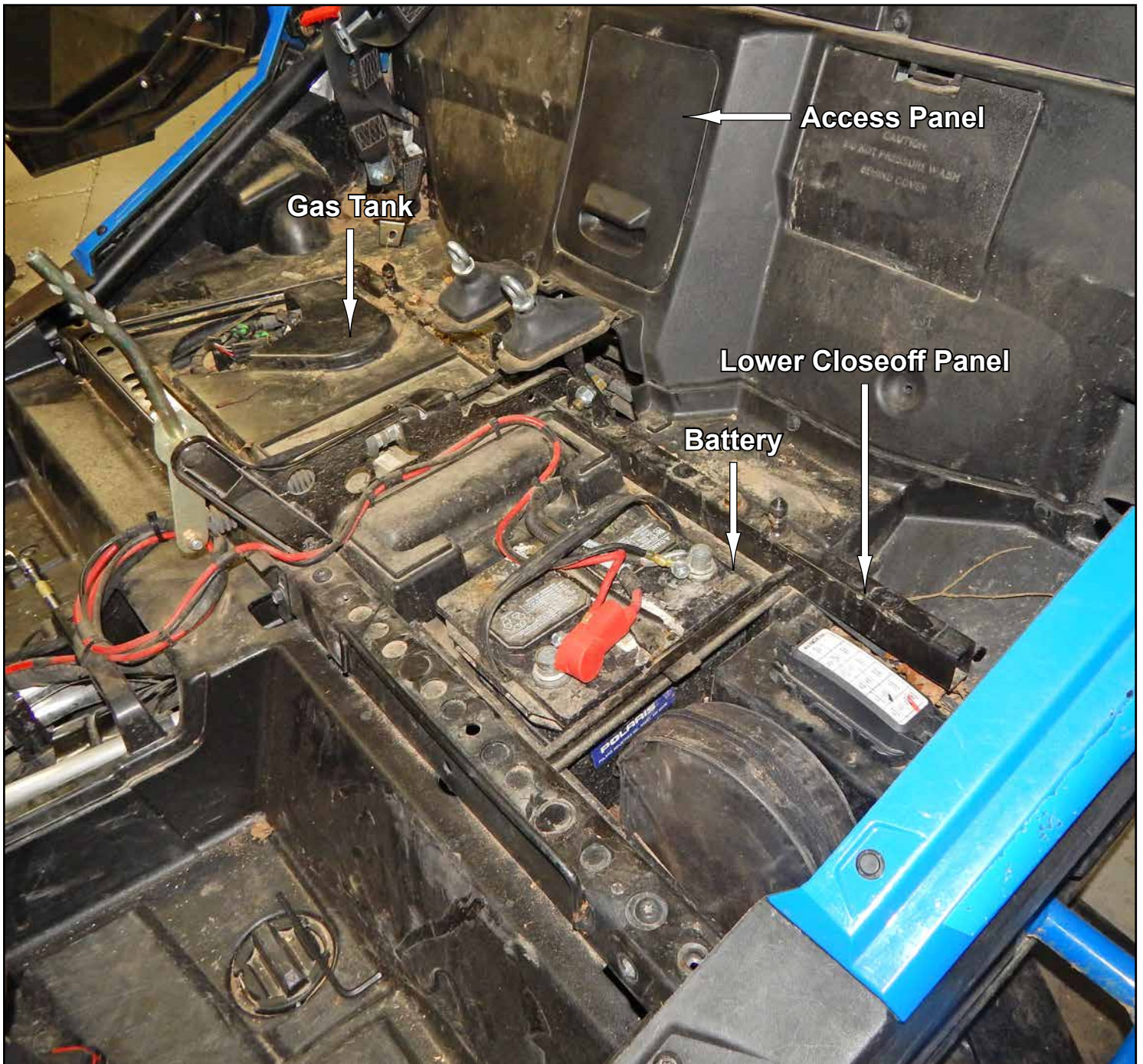



*(Passenger Side)*

remove Pin from Yoke on Front Prop



*(Driver Side)*

unbolt Rear Prop from Gear Case

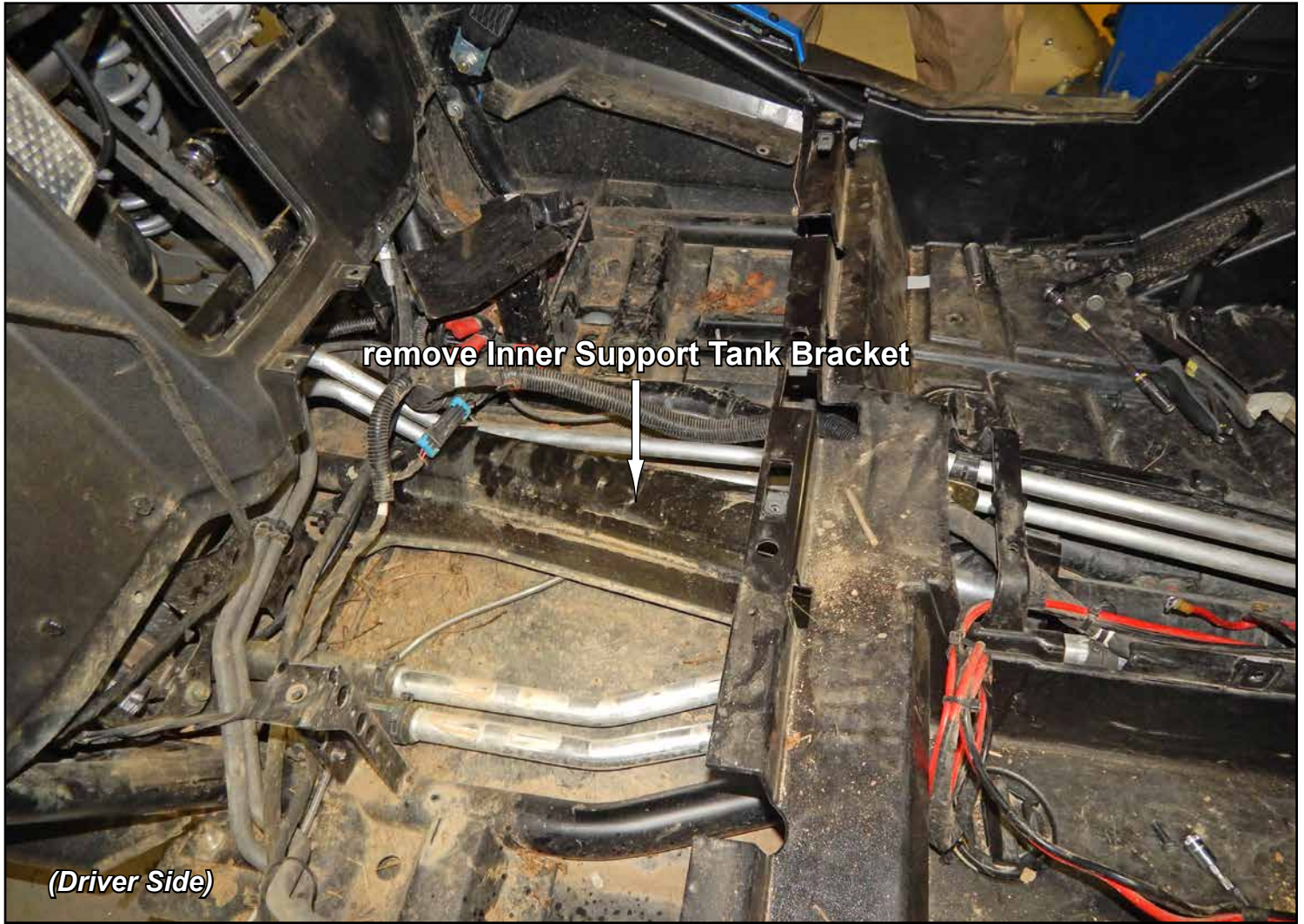

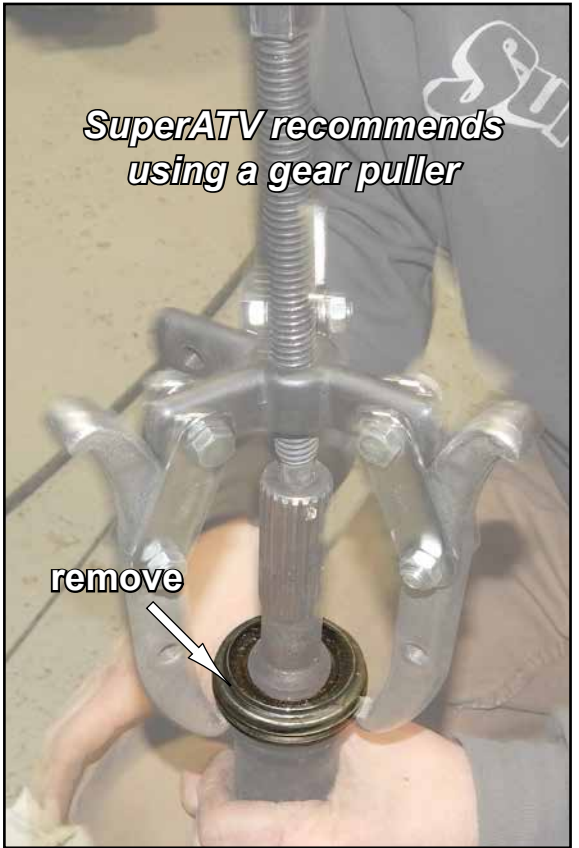

If installing onto a SuperATV Prop Shaft with a Snap Ring, do not install Retainer.



**Non-Turbo Models:** *(performed with vehicle flipped on its side)*

- Remove Skid Plate.
- Remove Pin from Yoke on Front Prop.
- Unbolt Carrier Bearing from machine.
- Separate Front Prop from Differential and Rear Prop; remove from machine.
- Separate Rear Prop Shaft from Gear Box.; remove from machine.

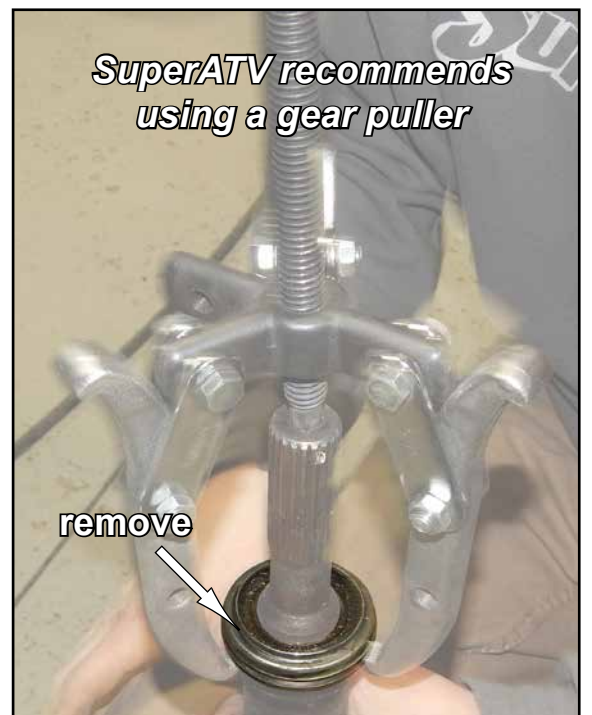
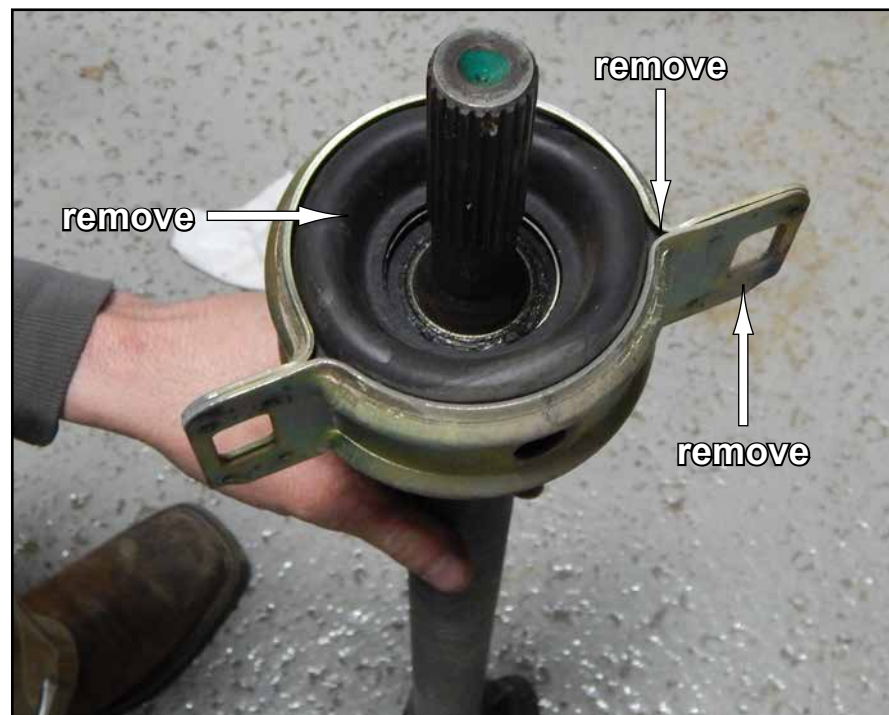
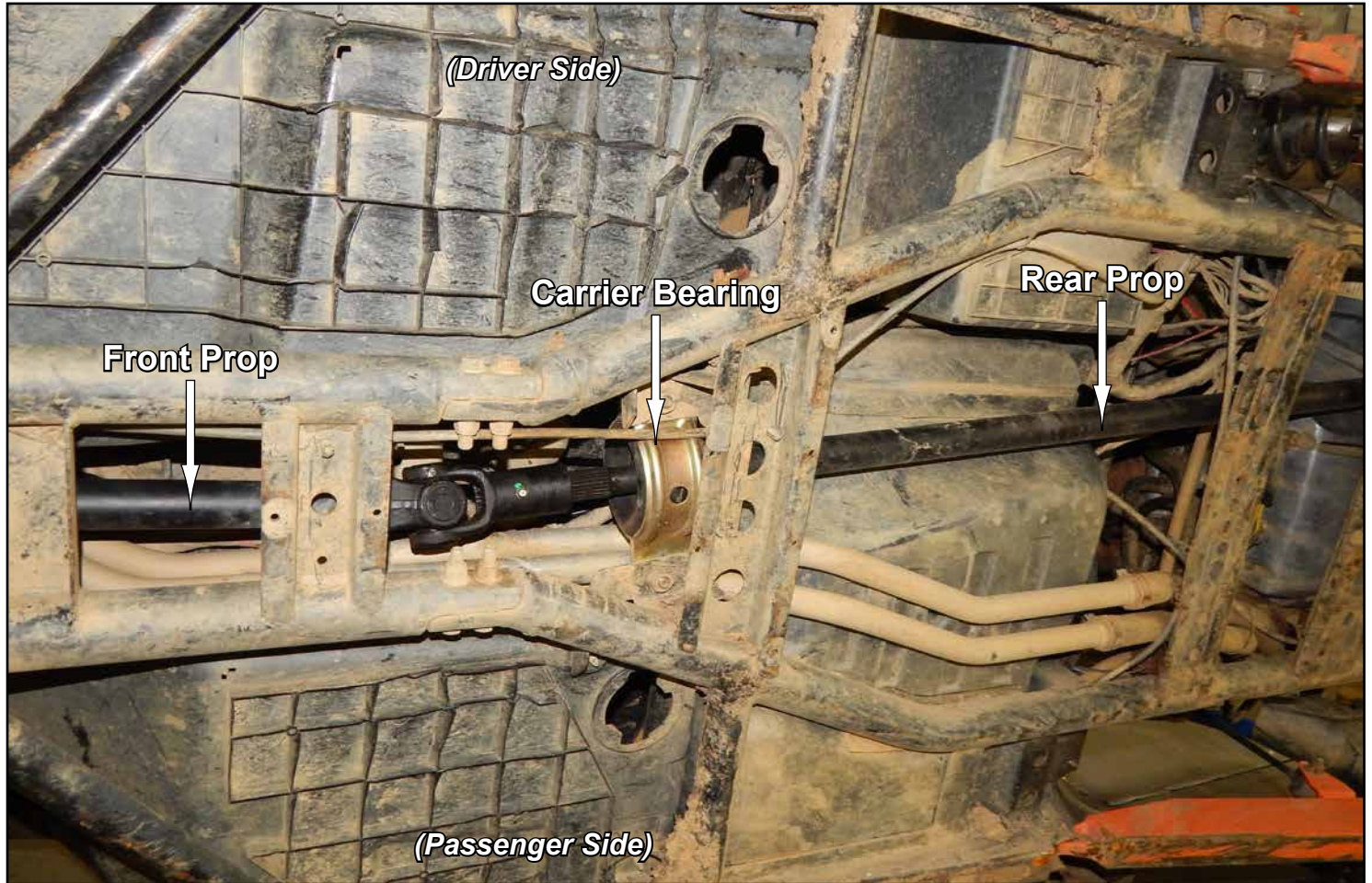

## Turbo Models:

- Completely clean off all oil, grease, or dirt on Shaft in highlighted area.
- Completely clean oil from seating area of Carrier Bearing.
- Apply supplied green retaining compound to Shaft.
- Install new Bearing.
- Install Retainer. Chamfer on Retainer will install towards Carrier Bearing. *Retainer must be in contact with Carrier Bearing*; use supplied blue Loc-Tite on Retainer hardware.
- **Must cure 24 hours before next step.**

*see following page for part number BEA01-005 installation notes*

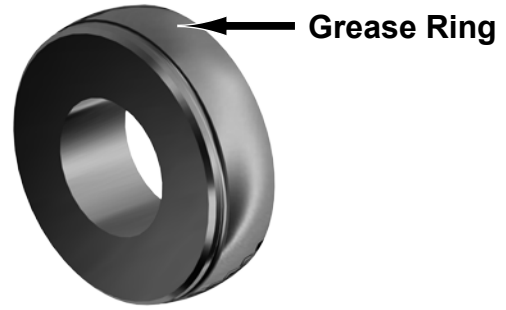
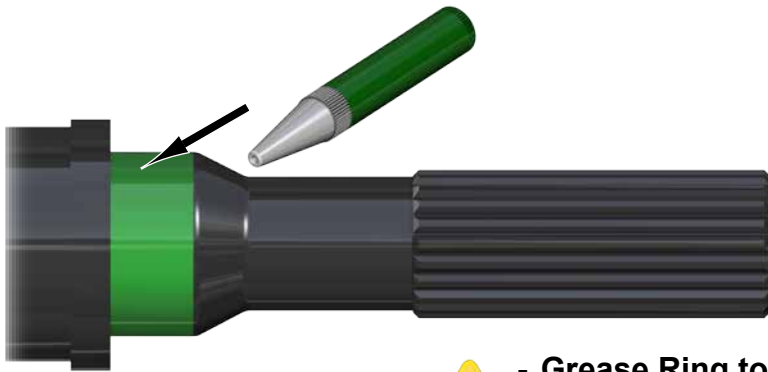

- Grease Ring to always face center of Bearing Carrier.
- Grease Ring to be in-line with Top and Bottom pieces.



**Top**

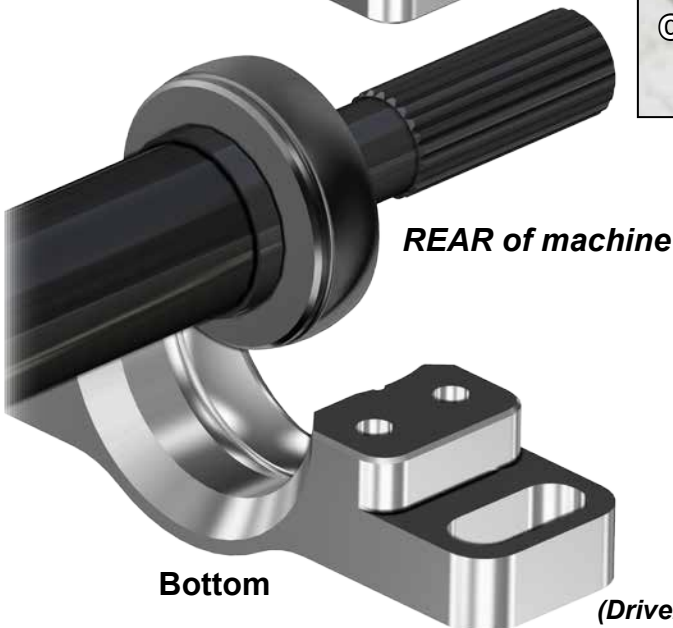

**REAR of machine**

**Bottom**

**(Driver Side)**

use provided hardware when securing to Frame

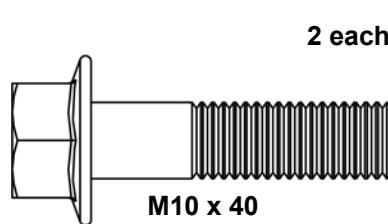

2 each

M10 x 40

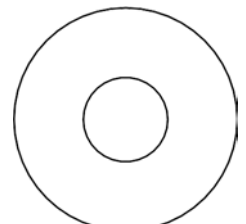

Washer



Part No. BEA01-005

long "ear" to face  
passenger side

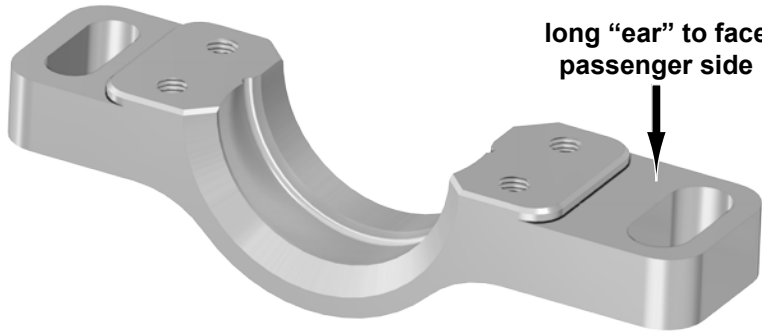

(Passenger Side)

(Driver Side)

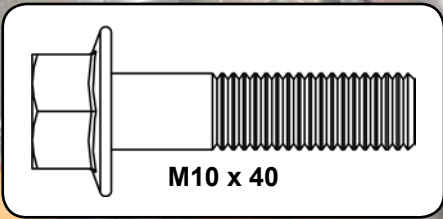
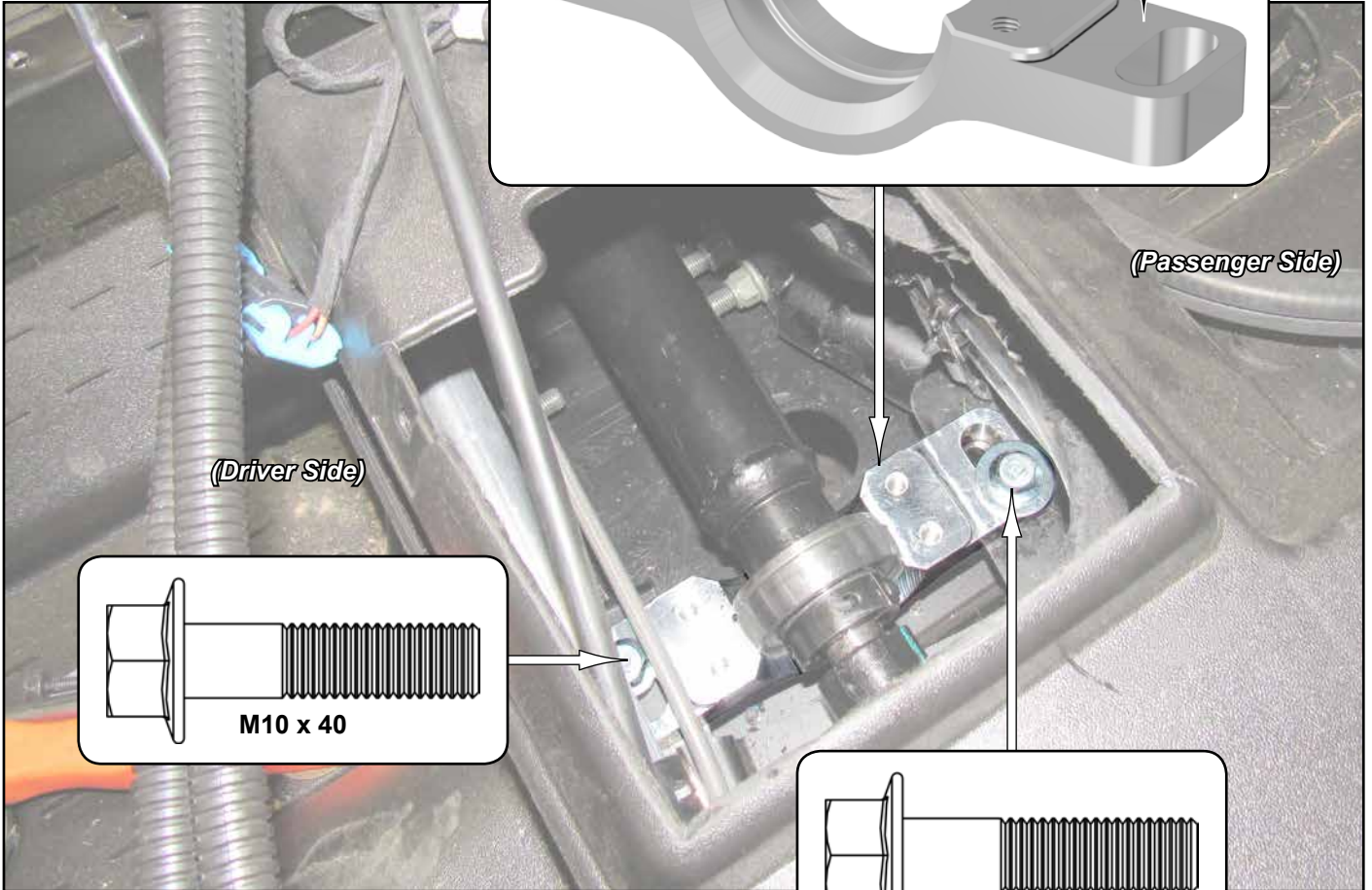

M10 x 40

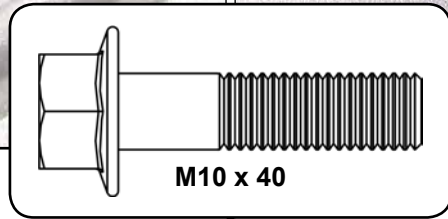

M10 x 40

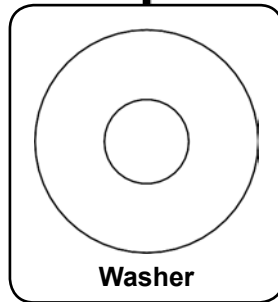

Washer

### Non-Turbo Models:

- Completely clean off all oil, grease, or dirt on Shaft in highlighted area.
- Completely clean oil from seating area of Carrier Bearing.
- Apply supplied green retaining compound to Shaft.
- Install new Bearing.
- Install Retainer. Chamfer on Retainer will install towards Carrier Bearing. *Retainer must be in contact with Carrier Bearing*; use supplied blue Loc-Tite on Retainer hardware.
- **Must cure 24 hours before next step.**

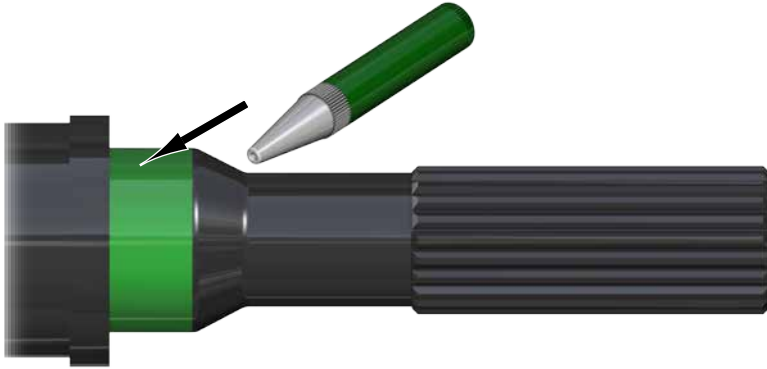

- Grease Ring to always face center of Bearing Carrier.
- Grease Ring to be in-line with Top and Bottom pieces.

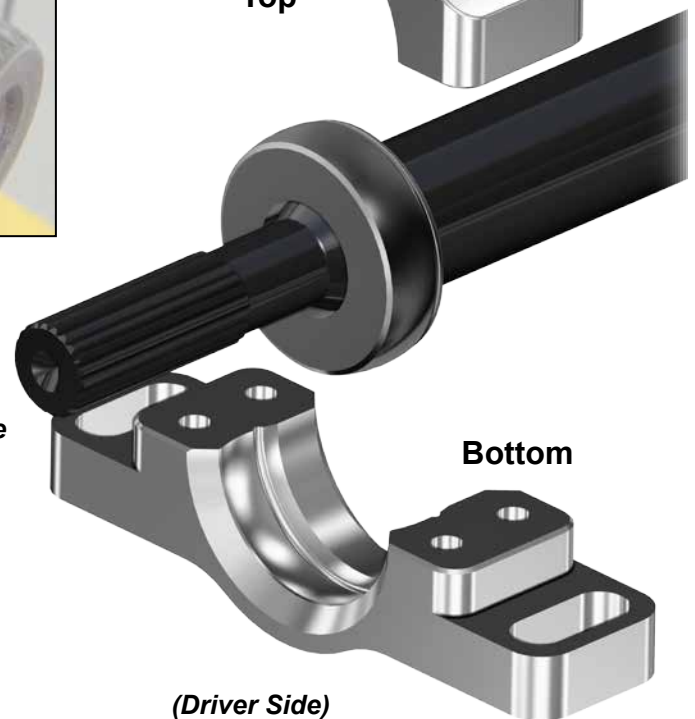



See last page for correct alignment illustrations.

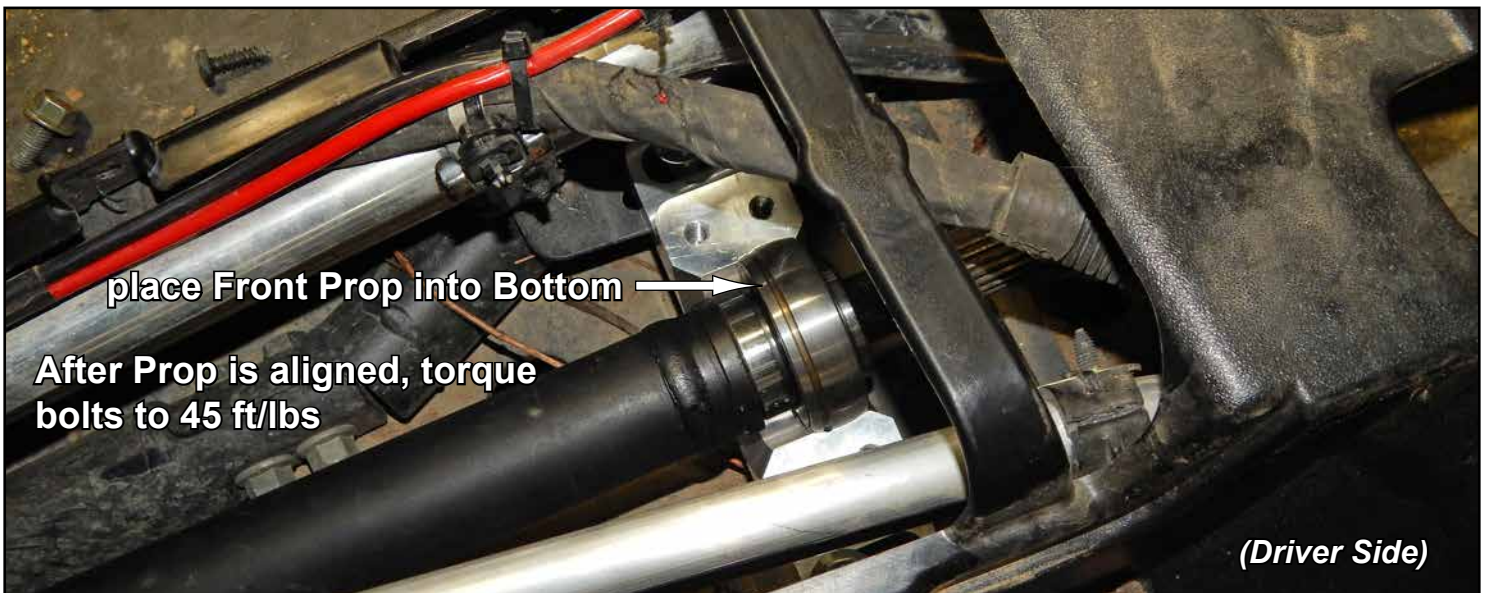

- Reinstall all components removed from machine.
- Use supplied blue Loc-Tite on bolts.

