



RAMHD-230/734KIT INSTALLATION MANUAL

REV: BETA (2/19/2018)



© Kleinn Air Horns 2018, All rights reserved.

PO Box 91278 Tucson, AZ 85752

Phone: (520) 579-1531

Web: www.Kleinn.com

This digital PDF is interactive.

Please save ink and paper...



Open interactive manual using Adobe Reader[®]

on [PC, MAC, and all smart devices](#)



RAMHD-230/734KIT

Installation and Operation Manual

Table of Contents

- 1. How to Use this Manual 4
 - 1.1. Interactive Manual using Adobe Reader 4
 - 1.2. Your Kit Part Number and this Manual 4
 - 1.3. Illustration/Photo Details and Orientation..... 4
- 2. Safety First 5
- 3. Application Chart 6
 - 3.1. 100% Direct Bolt-On Vehicle List 6
 - 3.2. **Excluded Vehicles 6
 - 3.3. Aftermarket Product Compatibility 6
- 4. Kit Installation Overview 7
 - 4.1. Approximate Installation Time 8
 - 4.2. ***Quick Install Outline 9
- 5. List of Tools and Supplies 10
 - 5.1. Standard Tool List (Required) 10
 - 5.2. Special Tool List (Recommended) 10
 - 5.3. Shop Consumables List (Recommended) 10
- 6. Parts List 11
 - 6.1. Pre-Packaged Electro-Mechanical Items 11
 - 6.2. Air Fittings and Related Items 12
 - 6.3. Electrical Small Components and Related Items 14
 - 6.4. Bolt-On Brackets and Hardware/Fasteners 14
- 7. Bench Assembly Steps 16
 - 7.1. Unpack and Layout Kit Parts..... 16
 - 7.2. Disassemble Train Horn Kit..... 16
 - 7.3. Mount Medium and Large Horn Drivers to Bracket 18
 - 7.4. Mount Small Horn Driver to Bracket 19
 - 7.5. Mount Air Tank to Bracket 21
- 8. On-Vehicle Mechanical Assembly Steps..... 23
 - 8.1. Large-Medium Horn Assembly Installation 23
 - 8.2. Small Horn Assembly Installation 25
 - 8.3. Air Tank Assembly Installation 28
 - 8.4. Compressor and Bracket Installation 30



RAMHD-230/734KIT

Installation and Operation Manual

9.	On Vehicle Air Line Installation	33
10.	On-Vehicle Electrical Installation.....	36
10.1.	Disconnect Vehicle Battery(s).....	36
10.2.	Attach Relay to Vehicle.....	36
10.3.	Route Wiring and Install Horn Button	36
10.4.	Connect Relay to Wiring	37
10.5.	Connect Air Horn Solenoid	37
10.6.	Reconnect Vehicle Battery(s)	37
11.	Initial Testing of Kit	38
11.1.	Test Air Compressor	38
11.2.	Test Train Horns.....	38
11.3.	Test Quick Connect Coupler	38
12.	General Operation of Kit	39
12.1.	Compressor Operation	39
12.2.	Horn Operation.....	39
13.	Routine Maintenance	40
14.	Warranty Information	41



RAMHD-230/734KIT

Installation and Operation Manual

1. How to Use this Manual

1.1. Interactive Manual using Adobe Reader

It is recommended to open this digital PDF using Adobe Reader[®] to take advantage of following key features:

- **Hyperlinks** ([blue underlined text](#)) allow access to additional content via internet; click/tap to activate
- **Table of Contents** page allows easily navigating this manual; click/tap any section line to go to it
- **Bookmarks** allow quickly navigating to any section; click/tap
- **Zoom IN** on pictures by pressing “CTRL and +” at same time on PC, or pinch in on smart devices
- **Zoom OUT** on pictures by pressing “CTRL and -” at same time on PC, or pinch out on smart devices

To install Adobe Reader[®]

On PC, or Mac

- visit <https://get.adobe.com/reader/otherversions/>

On Android, iPhone/iPad, and Windows devices,

- visit <https://acrobat.adobe.com/us/en/acrobat/mobile-app.html>
-

1.2. Your Kit Part Number and this Manual

This manual covers installation, testing, and operation of following kit part numbers

1. **RAMHD-230KIT** (i.e., 230 Train Horns)
2. **RAMHD-734KIT** (i.e., 730 Train Horns)

NOTE: Illustrations and pictures contained herein may represent only one kit part number. Where critical differences exist between kits (i.e., different parts, orientation, mounting points, etc.), additional text, or necessary graphics are provided to minimize confusion.

Parts list explicitly state kit differences with **(BOLD TEXT)** inside parenthesis, shown below part number.

1.3. Illustration/Photo Details and Orientation

This manual may use digitally created illustrations, and/or actual photos of example vehicle. These graphics may not include exact items found on your vehicle (i.e., electrical wiring, fuel lines, body panels, etc.). Illustrations typically will be missing details and are for clarity to show critical mounting locations and orientation on vehicle.

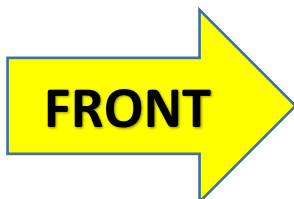

Throughout this manual yellow arrows with text reading “FRONT”, may be present over illustrations and pictures. These arrows specify direction toward front of vehicle and provide clarity to how illustration is viewed.



RAMHD-230/734KIT

Installation and Operation Manual

2. Safety First

Read manual thoroughly before starting installation of this kit. Verify you have all parts listed and that you clearly understand this installation procedure. Contact Kleinn technical support for any questions.

Installation of this kit requires **moderate mechanical aptitude**; seek professional help if you're not competent using hand tools in tight uncomfortable spaces, and around possibly rusted and sharp vehicle parts.

Before starting, obtain proper tools required to perform installation correctly, adequate lighting, eye protection, hearing protection for operating train horns, and hand protection to guard against sharp edges and metal burrs, which may be present on kit parts and vehicle parts.

Throughout this manual the following words may be used; be aware of their meaning and application.

CAUTION: means damage could occur to vehicle, or kit parts during, or after installation

WARNING: means injury could occur to you or others, including damage to vehicle, or kit parts

DANGER: means serious injury or death could occur to you or others during installation



RAMHD-230/734KIT

Installation and Operation Manual

3. Application Chart

3.1. 100% Direct Bolt-On Vehicle List

RAMHD-230/734KIT is a 100% direct bolt-on aftermarket product for DODGE vehicles listed in below chart; every effort has been made to verify correct fitment on these vehicles in their factory, non-modified conditions.

MODEL YR	MODEL	DRIVE	ENGINE	BODY	TRIM
2014-2018	RAM 2500	2WD, 4WD	ALL	Crew Cab (<i>short bed**</i>), Mega Cab	ALL
2014-2018	RAM 3500	2WD, 4WD, DUALIE	ALL	Crew Cab (<i>short bed**</i>), Mega Cab	ALL

NOTE: All vehicles listed may require drilling holes for ground wires and installing switches, based on preference of installed switch locations and wire grounding points.

3.2. **Excluded Vehicles

RAMHD-230/734KIT may not be compatible with following DODGE vehicles:

1. All Crew Cab Long Bed model years listed
2. All Regular/Standard Cabs model years listed

Kit may be adapted to these vehicles, with vehicle modification:

1. Small Horn Bracket
 - Drill mounting holes in vehicle chassis at approximate location shown in instructions
2. Compressor Bracket
 - Drill mounting holes in vehicle chassis at approximate location shown in instructions

CAUTION: All vehicle modifications are at discretion of end-user/installer; this manual does NOT provide instruction, or encourage such modification. Contact Kleinn sales for more information.

3.3. Aftermarket Product Compatibility

This kit has been designed and tested to be compatible with leading manufacturers of aftermarket truck steps, such as Amp Research Power Steps[®] and all OEM standard and optional steps.



RAMHD-230/734KIT

Installation and Operation Manual

4. Kit Installation Overview

RAMHD-230/734KIT consists of the following major components, located on vehicle per following pictures and chart

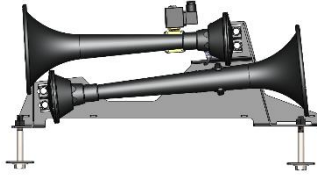
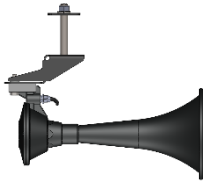
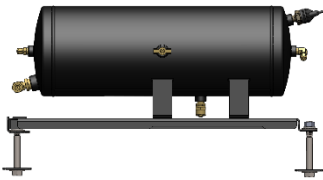
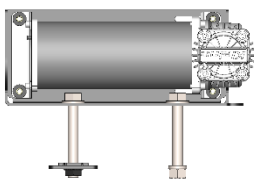
ITEM	DESCRIPTION	PICTURE	MOUNTING LOCATION	APPROX. INSTALL TIME
1	230/730 Series Large and Medium Horn with Mounting Bracket and Air Solenoid		Under driver side front door. Bolted to outside of frame rail.	2+ Hours
2	230/730 Series Small Horn with Mounting Bracket		Under driver side rear door. Bolted to outside of frame rail.	1-2 Hours
3	Air Tank with Mounting Bracket		Under passenger side front door. Bolted to outside of frame rail.	2+ Hours
4	6350RC/6450RC Air Compressor with Mounting Bracket		Under passenger side rear door. Bolted to outside of frame rail.	1-2 Hours

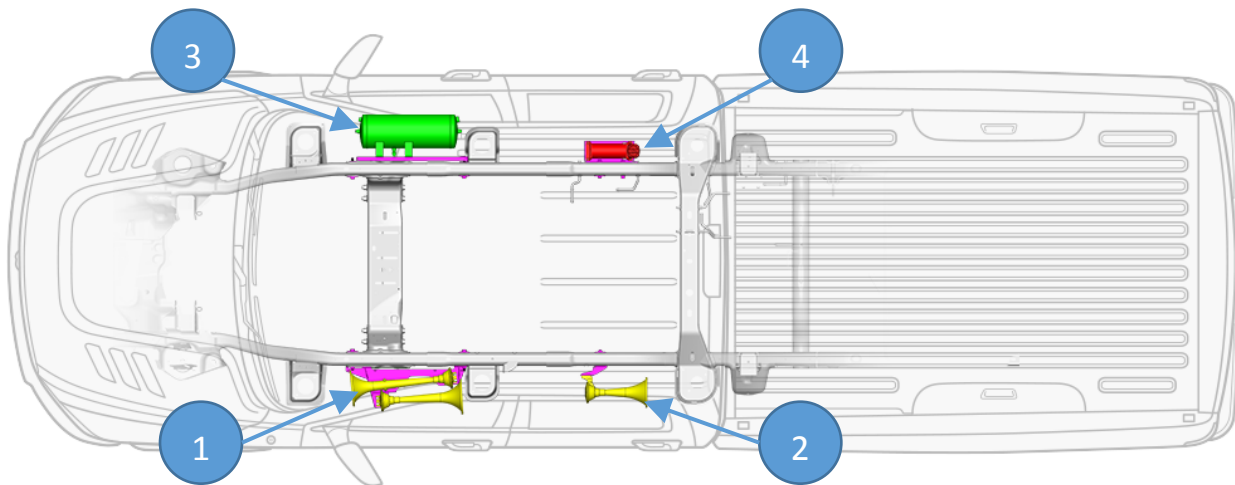

Top View – Ram 2500 Crew Cab Short Bed (734KIT Shown)

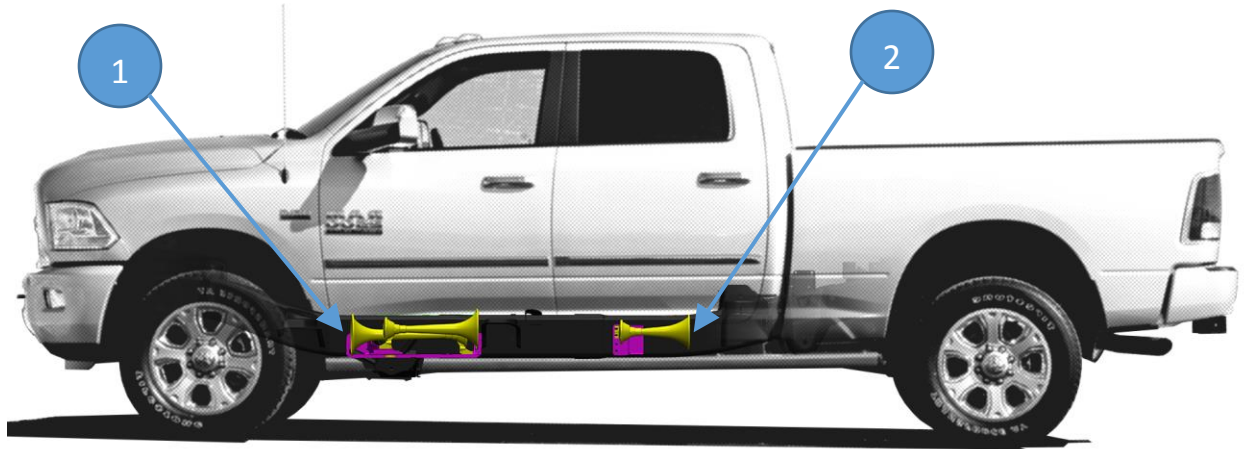

Driver Side View – 2014 Ram 2500 Crew Cab Short Bed (734KIT Shown)

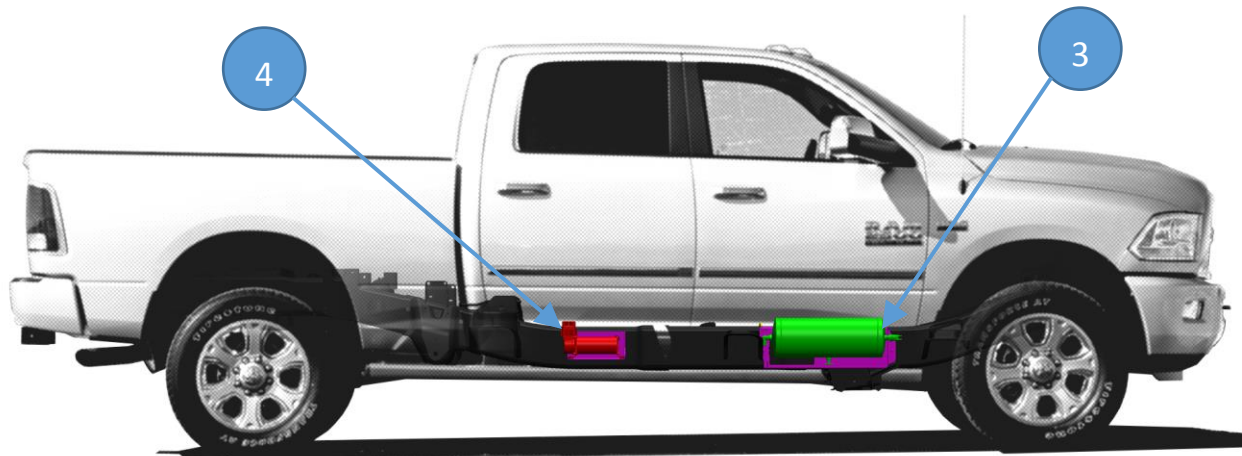

Passenger Side View – 2014 Ram 2500 Crew Cab Short Bed (734KIT Shown)

4.1. [Approximate Installation Time](#)

RAMHD-230/734KIT is a multi-faceted product consisting of multiple mechanical, electrical, and pneumatic components.

For a typical home mechanic, auto enthusiast, or technician installing a Kleinn Bolt-On kit for first time, a professional installation job with setup and testing of final product, is estimated to take:

- **8-12 Hours**
-



RAMHD-230/734KIT

Installation and Operation Manual

4.2. ***Quick Install Outline

For person(s) with experience installing Kleinn bolt-on kits, RAMHD-230/734KIT can be installed in an order similar to below:

1. Route wiring, install Relay, and Horn Switch
2. Disassemble 230/730 Horn Kit (i.e., separate drivers from trumpets and horn mounting plate)
3. Assemble Air Fittings to Air Tank
4. Mount Medium & Large Horn Drivers to Front Horn Bracket
5. Mount Small Horn Driver to Rear Horn Bracket
6. Mount Air Tank to Bracket
7. Mount Medium-Large Horn Bracket Assembly to Frame; install Horn Trumpets
8. Mount Small Horn Bracket Assembly to Frame; install Horn Trumpet
9. Mount Air Tank Bracket Assembly to Frame
10. Mount Air Compressor Bracket to Frame and Mount Air Compressor to Bracket
11. Route Air Tubing, Quick Connect Coupler, Air Compressor filter, and connect all Pneumatic components
12. Connect wiring to all components
13. Test System and adjust, as needed



RAMHD-230/734KIT

Installation and Operation Manual

5. List of Tools and Supplies

5.1. Standard Tool List (Required)

1. Basic mechanic's 3/8" drive socket sets with extensions
 - a. Inch Size Sockets (1/4" – 1" Hex)
 - b. Metric Size Sockets (6mm – 20mm Hex)
2. Basic mechanic's combination wrenches (box/open-end)
 - a. Inch Size Wrenches (1/4" – 1" Hex)
 - b. Metric Size Wrenches (6mm – 20mm Hex)
3. Basic mechanic's screwdriver set (Philips, Flat Head)
4. Diagonal Cutter/Wire Cutter Pliers
5. Wire Strippers
6. Wire Terminal Crimpers
7. Slip-Joint Pliers
8. Utility Knife, or Utility Razor blade

5.2. Special Tool List (Recommended)

1. 10-100 ft.-lb. torque wrench
2. 50-150 in.-lb. torque wrench
3. Multi-Meter for 12V DC electrical systems, or equivalent
4. 12V DC Test Light, or equivalent

5.3. Shop Consumables List (Recommended)

1. Quality Electrical tape
2. Di-electric grease for electrical connections
3. Heat Shrink tubing for electrical connections
4. Sand Paper, or Wire Brushes for installing ground wires
5. Extra plastic zip ties > 6" long
6. Extra NPT sealant (i.e., Kleinn Air Horn Juice, Teflon tape, etc.)
7. Touch-up paint for frame/chassis
8. Typical cleanup supplies



RAMHD-230/734KIT

Installation and Operation Manual

6. Parts List



RAMHD-230/734KIT includes all major items listed below

This parts list covers following kit part numbers

1. **RAMHD-230KIT** (i.e., 230 Train Horns)
2. **RAMHD-734KIT** (i.e., 730 Train Horns)

6.1. Pre-Packaged Electro-Mechanical Items

NOTE: Items in this section come in their own packages and may include additional items inside package

ITEM	QTY	PART NUMBER	DESCRIPTION	PICTURE
1	1	6350RC (230KIT ONLY)	6350RC Compressor Kit, with included hardware, and remote air supply line	
1	1	6450RC (734KIT ONLY)	6450RC Compressor Kit, with included hardware, and remote air supply line	
2	1	230 (230KIT ONLY)	230 Series Horn Kit, with included solenoid/valve, and 1/4" Air Tubing, 12 ft. long	
2	1	730 (734KIT-ONLY)	730 Series Horn Kit, with included solenoid/valve, and 1/4" Air Tubing, 12 ft. long	



RAMHD-230/734KIT

Installation and Operation Manual

6.2. Air Fittings and Related Items

ITEM	QTY	PART NUMBER	DESCRIPTION	PICTURE
3	1	6355RT	Air Tank, 6-Port, Narrow Legs	
4	2	51414L (view location on Air Tank)	1/4" NPT X 1/4" Compression Fitting, 90 Deg Elbow	
5	1	52835 (view location on Air Tank)	1/4" NPT, Drain Valve	
6	1	52175 (view location on Air Tank)	1/4" NPT, 175 PSI Safety Valve	
7	1	51214L (734KIT-ONLY) (view location on Air Tank)	1/4" NPT X 1/2" Compression Fitting, 90 Deg Elbow	
8	1	51214R (734KIT-ONLY) (view location on Air Tank)	1/2" NPT FEMALE X 1/4" NPT Reducer Fitting	
8	1	51412 (230KIT ONLY) (view location on Air Tank)	1/2" NPT X 1/4" Compression Fitting	

RAMHD-230/734KIT

Installation and Operation Manual





9	1	2151 (view location on Air Tank)	1/4" NPT Pressure Switch	
10	1	51414F	1/4" NPT FEMALE X 1/4" Compression Fitting	
11	2	25014 (230KIT ONLY)	1/4" Air Tubing, 12 ft. long	
11	2	25012 (734KIT ONLY)	1/2" Air Tubing, 12 ft. long	
12	1	1302	Quick Connect Air Coupler Kit, with relocation bracket	
13	1	INF-1	Inflator Kit, with Air Hose and Bag	
14	1	KLEINN AIR HORN JUICE	Thread Sealant for NPT Fittings	





RAMHD-230/734KIT

Installation and Operation Manual

6.3. Electrical Small Components and Related Items

ITEM	QTY	PART NUMBER	DESCRIPTION	PICTURE
15	1	320	Terminator – Nickel Plated Remote Horn Button	
16	1	WIRE KIT	Full Wire Kit, with electrical connectors and zip ties	
17	1	1/4" WIRE LOOM, 20 ft. Long	1/4" Wire loom for electrical routing	
18	1	1/8" WIRE LOOM, 10 ft. Long	1/8" wire loom for electrical routing	

6.4. Bolt-On Brackets and Hardware/Fasteners

ITEM	QTY	PART NUMBER	DESCRIPTION	PICTURE
19	1	RAMHD HARDWARE	1/2"-13 Bolts, Nuts, and Washers for bracket mounting	
20	1	4 BOLT TANK HARDWARE	7/16"-14 Bolts, Nuts, and Washers for tank mounting	

RAMHD-230/734KIT

Installation and Operation Manual

21	1	HORN SEPARATION HARDWARE	5/16"-18 Bolts, Nuts, and Washers for horn mounting	
22	1	RAMHD_HORN-LG_BRKT-ASSY	Medium-Large Horn Bracket	
23	1	RAMHD_HORN-SM_BRKT	Small Horn Bracket	
24	1	RAMHD_TANK_BRKT-ASSY	Air Tank Bracket	
25	1	RAMHD_COMPRESSOR_BRKT	Air Compressor Bracket	
26	6	RAMHD_WASHER	Washer for Frame Slots	

7. Bench Assembly Steps

Complete following steps off vehicle to facilitate final installation.

7.1 Unpack and Layout Kit Parts

Unpackage RAMHD-230/734KIT and verify all parts are included per above Parts List. Contact Kleinn support if any questions arise.

It is recommended to layout and organize parts across a large work bench, or table in following order:

1. Review train horn box and included hardware
2. Review air compressor box and included hardware
3. Review air tank box and included hardware
4. Review kit mounting brackets and included hardware
5. Review electrical/air fittings and included wiring and tubing

7.2 Disassemble Train Horn Kit

1. Remove trumpets from drivers and set aside.
 - a. Starting with largest trumpet, tightly grasp trumpet with both hands and unscrew counter clockwise; trumpet may be very tight. Repeat on medium trumpet, then small.
 - i. Drivers are identical and do NOT require marking Small, Medium, Large
 - b. If necessary, clamp horn mounting plate to rigid table, in vise, or seek help to hold plate.

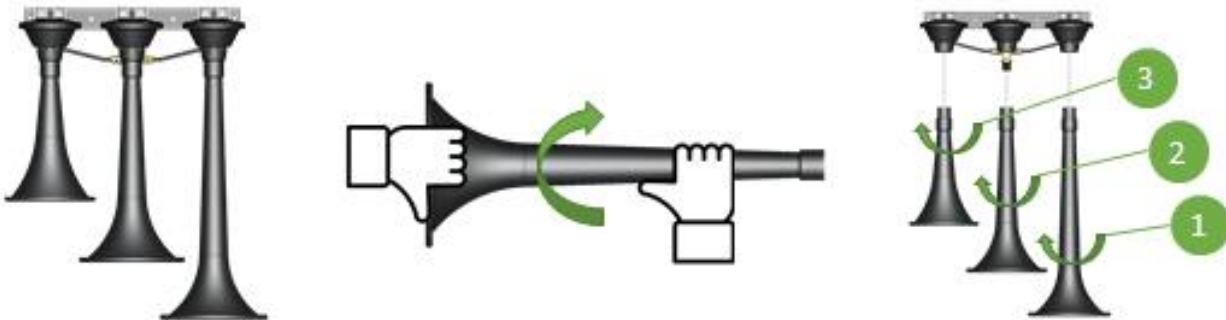

2. Cut semi-rigid plastic air tubing between horns.
 - a. Use sharp side/diagonal cutters, or equivalent to safely sever tubing.

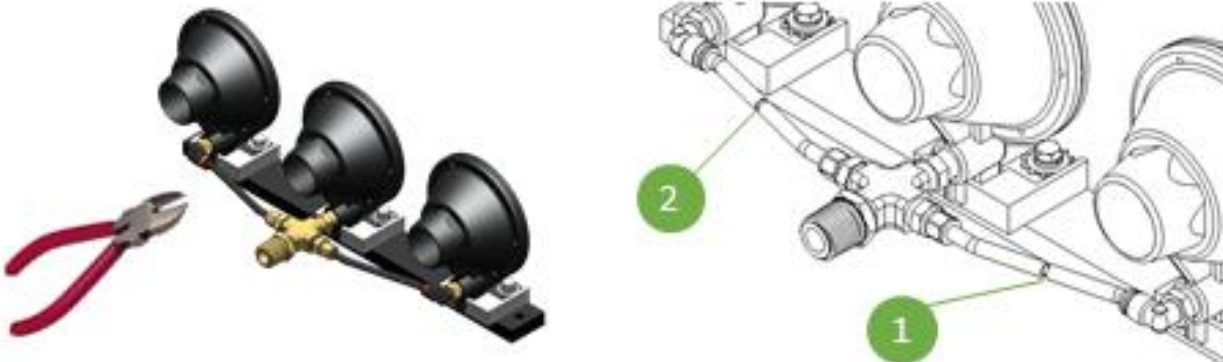

RAMHD-230/734KIT

Installation and Operation Manual

WARNING: tubing is difficult to sever using any type of fixed blade (i.e., knife, razor blade, box cutter, etc.)

3. Loosen Compression Nuts on center driver and remove horn drivers from mounting plate.
 - a. Use properly sized socket, or box-end wrench.
 - b. Horn mounting plate and fasteners will NOT be re-used during installation.



4. Remove cut tubing from fittings.
 - a. Using slip-joint pliers, or equivalent, pull and twist off tubing connected to compression fittings.
 - b. Depress collar on quick release fitting with one hand, then twist and pull plastic tube out with other hand. If necessary, use slip-joint pliers, or equivalent to twist and pull tubing out.

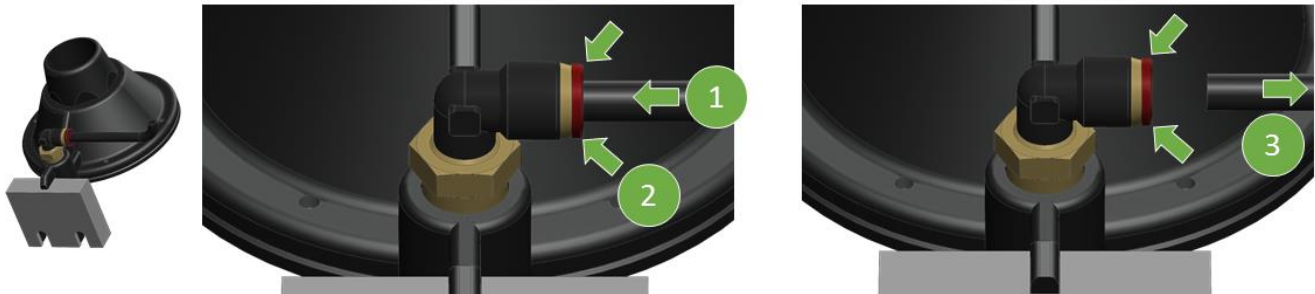

- c. For further instruction on properly using quick fittings, reference this [SMC Video](#)
 - d. Discard old tubing.

7.3 Mount Medium and Large Horn Drivers to Bracket

1. Attach Horn Driver to bracket with Large trumpet and Ore Mount (734KIT Only), per below illustration.

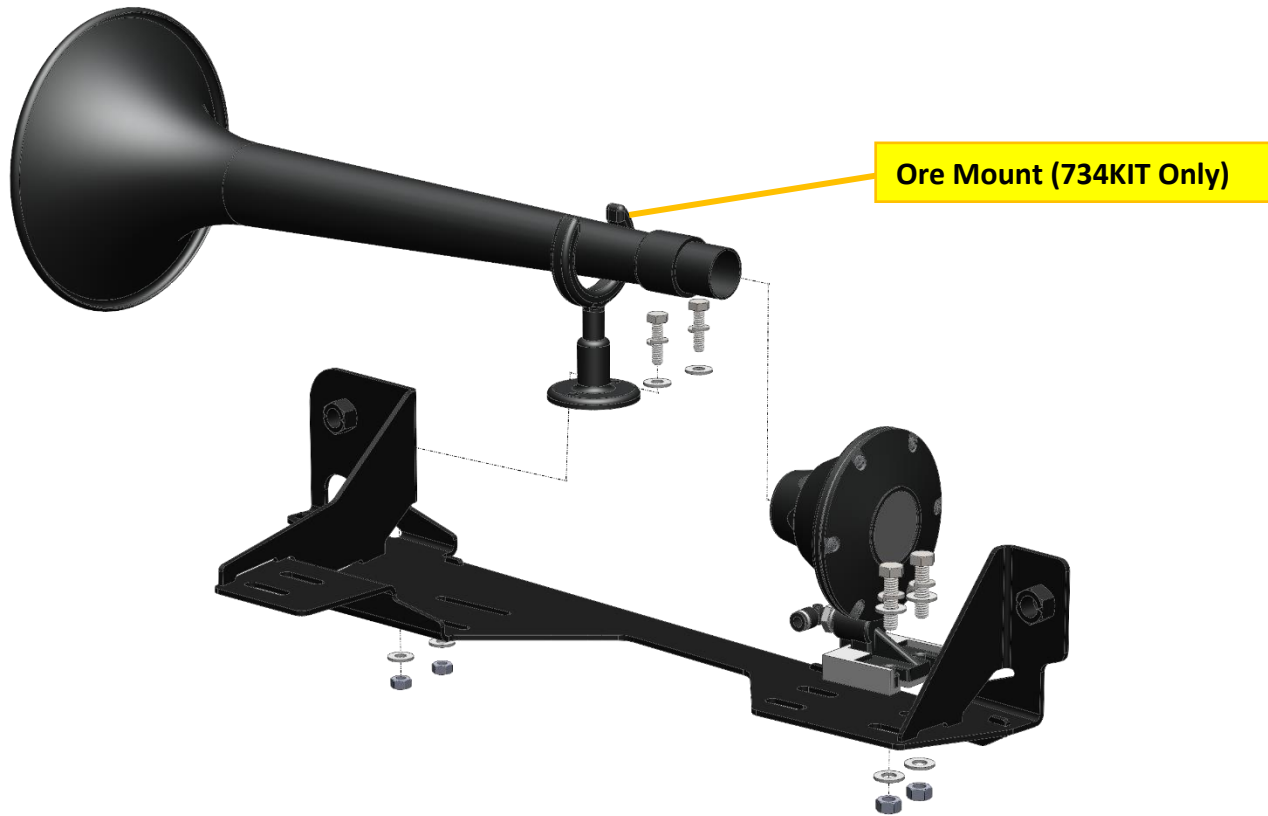

(734KIT Shown)

- a. Use Horn Separation Hardware kit
 - i. Assemble fasteners clean and dry using proper socket and box-end wrench.
- b. Do not use Ore Mount Rubber Bushing (included in kit).

RAMHD-230/734KIT

Installation and Operation Manual

2. Attach Air Solenoid and fitting to Horn Driver with built-in tee and attach to bracket, per below illustration.

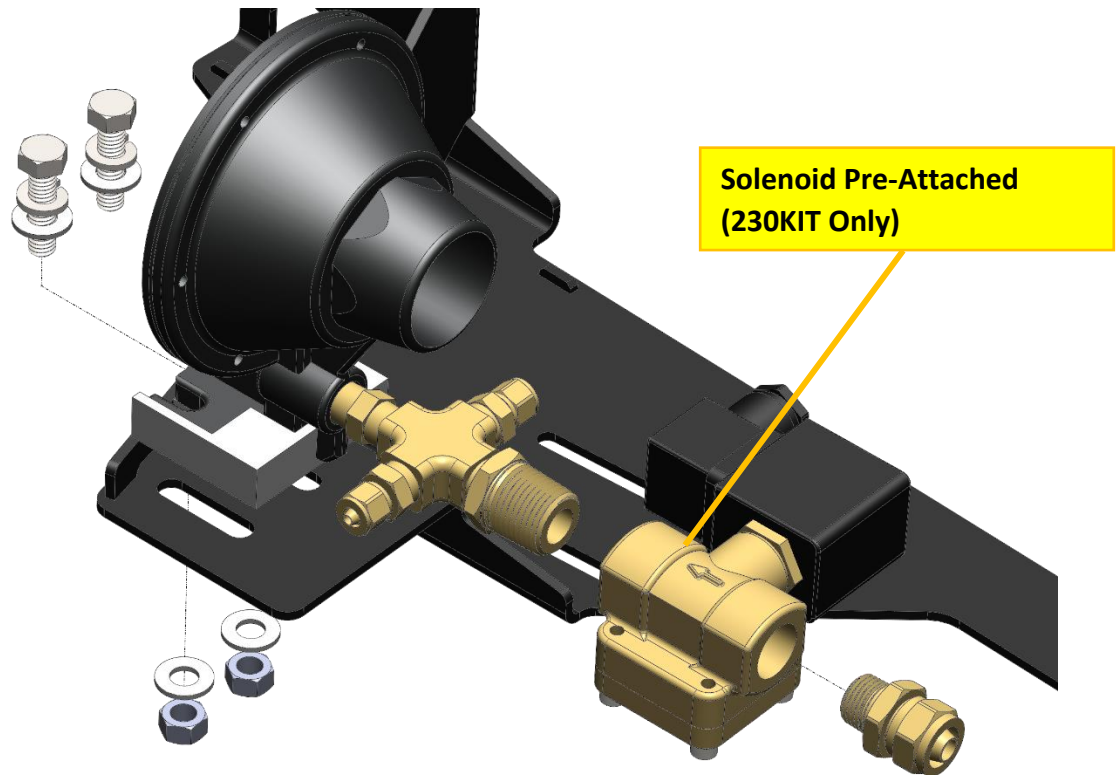

(734KIT Shown)

- a. Apply two small drops of [Kleinn Air Horn Juice](#) to male pipe threads.
 - i. Hand-tighten each fitting, then further tighten with wrench 1/4-1/2 turn
 - ii. Verify that air flow arrow on Solenoid points to horn driver and facing up.
- b. Use Horn Separation Hardware kit and hand-tighten fasteners to bracket.
 - i. Assemble fasteners clean and dry using proper socket and box-end wrench
 - ii. Final tightening will be completed on vehicle.

7.4 Mount Small Horn Driver to Bracket

1. Attach Small Horn Driver to bracket, per below illustration
 - a. Use Horn Separation Hardware kit
 - i. Assemble fasteners clean and dry, and finger tighten; they should be tight enough that horn driver does not move freely, but can be repositioned with some hand force.
 - ii. Final tightening will be completed on vehicle.
 - iii. Observe correct driver orientation, based on specific vehicle.

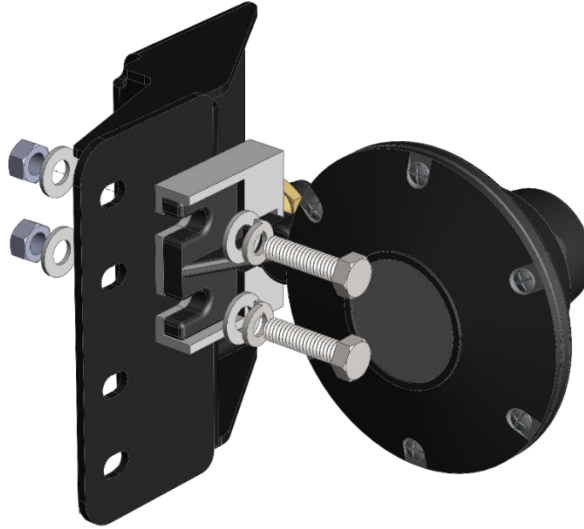

Crew Cab Orientation (top slots - bracket facing to right)

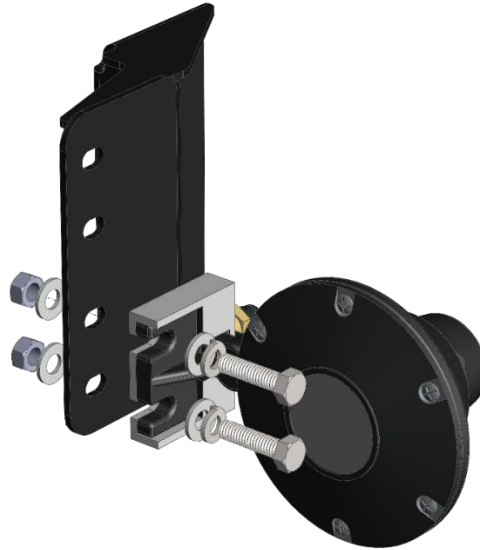

Mega Cab Orientation (bottom slots - bracket facing to right)

7.5 Mount Air Tank to Bracket

1. Attach and tighten air fittings to tank, per below illustrations.
 - a. Apply two small drops of [Kleinn Air Horn Juice](#) to each male pipe thread.
 - b. Hand-tighten each fitting, then further tighten each 1/4-1/2 turn using proper sized box-end wrench; adjust as necessary to match fitting orientation shown.
 - c. Match item numbers to Parts List; [Go to Fittings List](#)

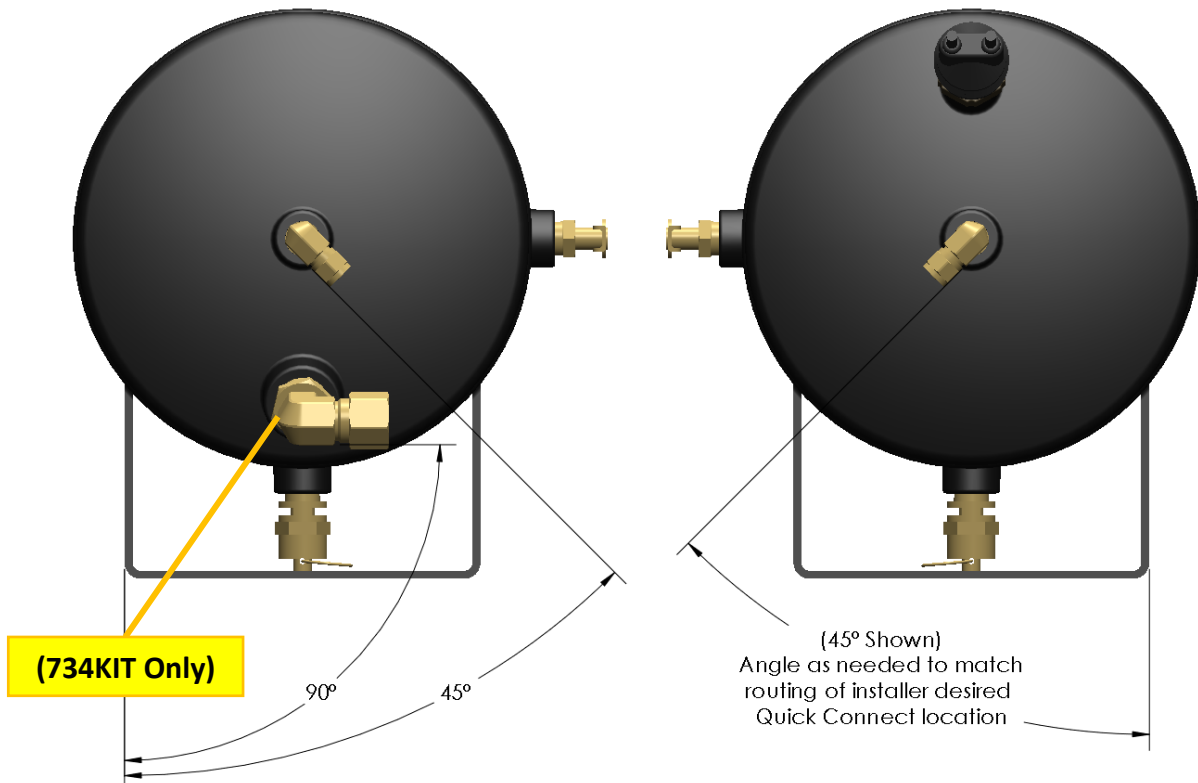
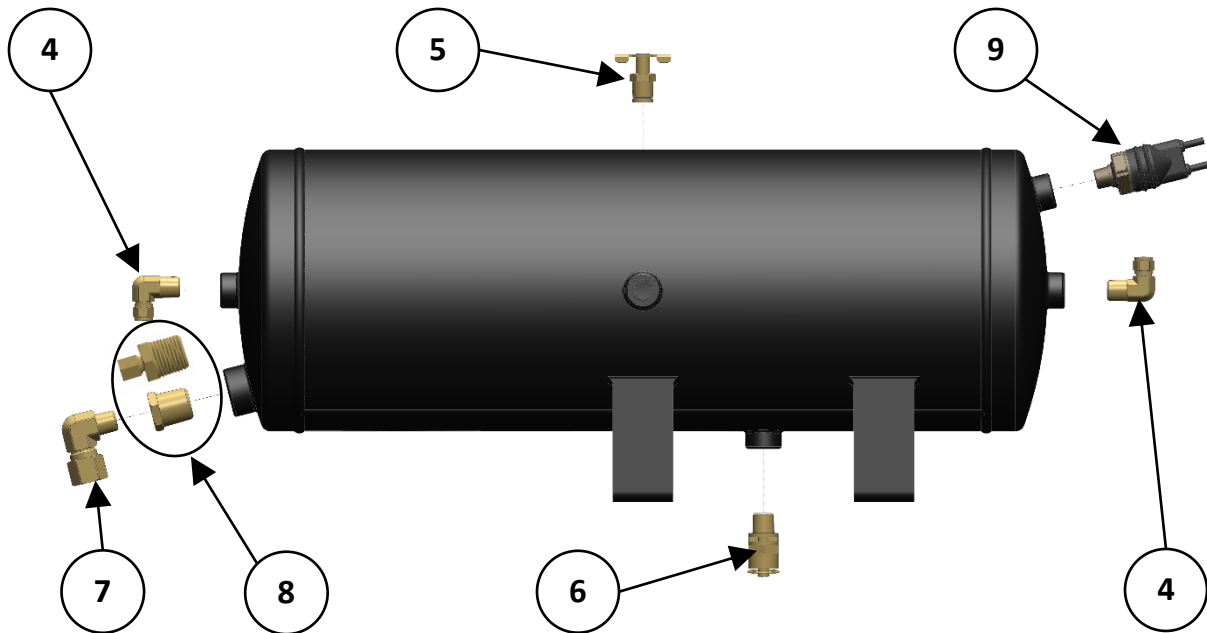

RAMHD-230/734KIT

Installation and Operation Manual

2. Attach air tank to bracket, per below illustration.
 - a. Use 4 Bolt Tank Hardware kit
 - i. Assemble fasteners clean and dry; tank should not move freely, but can be repositioned with some hand force.
 - ii. Final tightening will be completed on vehicle.



8. On-Vehicle Mechanical Assembly Steps

Complete following steps on vehicle.

Raise vehicle off ground using appropriate vehicle lift, ramps, or jack stands.

DANGER: Installation requires being underneath vehicle and applying forces to vehicle chassis. Follow all recommended safety precautions for raising vehicle; consult vehicle owner's manual.

8.1 Large-Medium Horn Assembly Installation

1. Attach Large-Medium Horn bracket assembly onto vehicle chassis, per below illustration.
 - a. Use RAMHD Hardware kit.
 - i. Finger tighten fasteners only, but ensure bracket is sitting entirely flush on chassis.
 - b. Install Medium trumpet into open driver and tighten firmly.

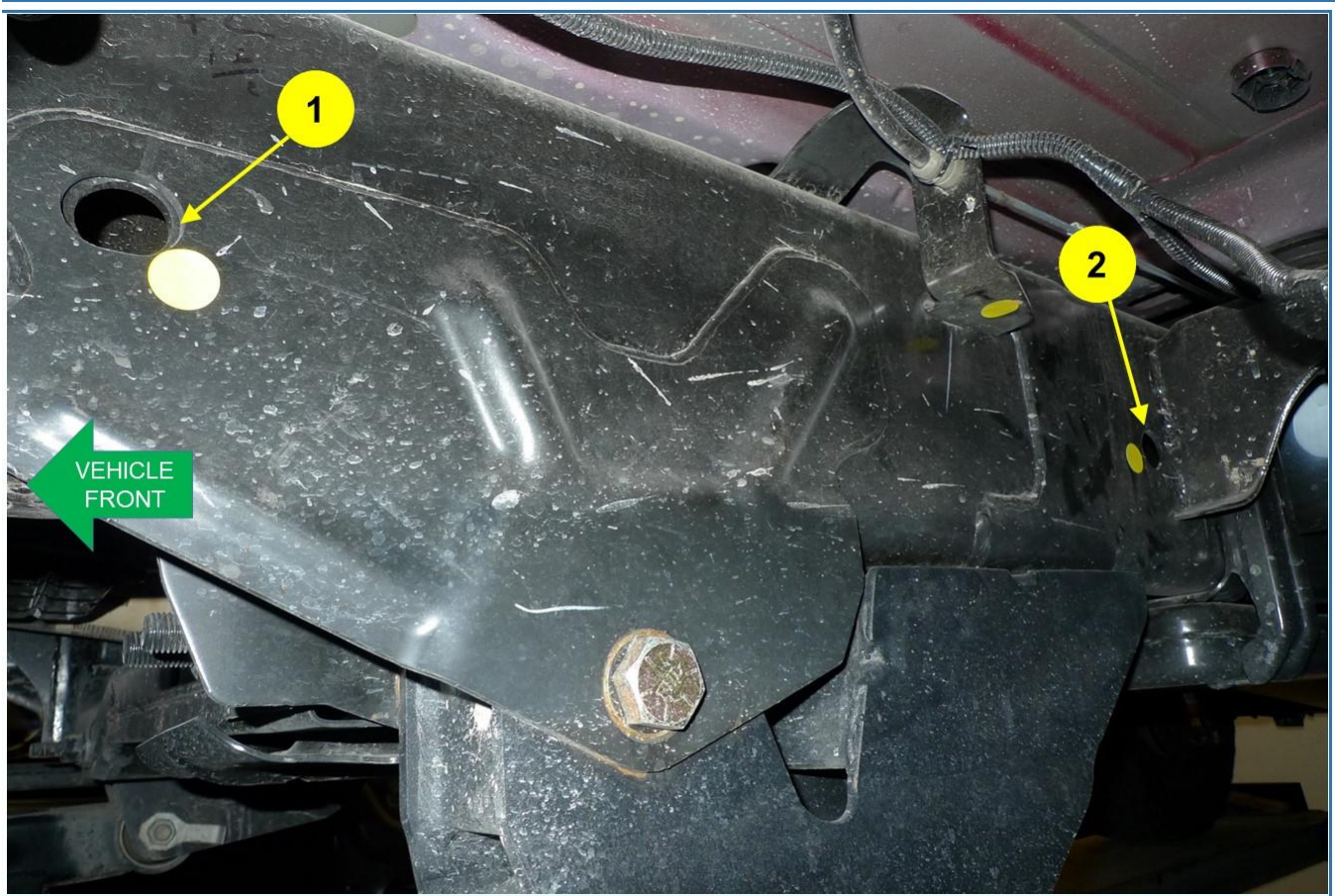

Crew Cab and Mega Cab Orientation

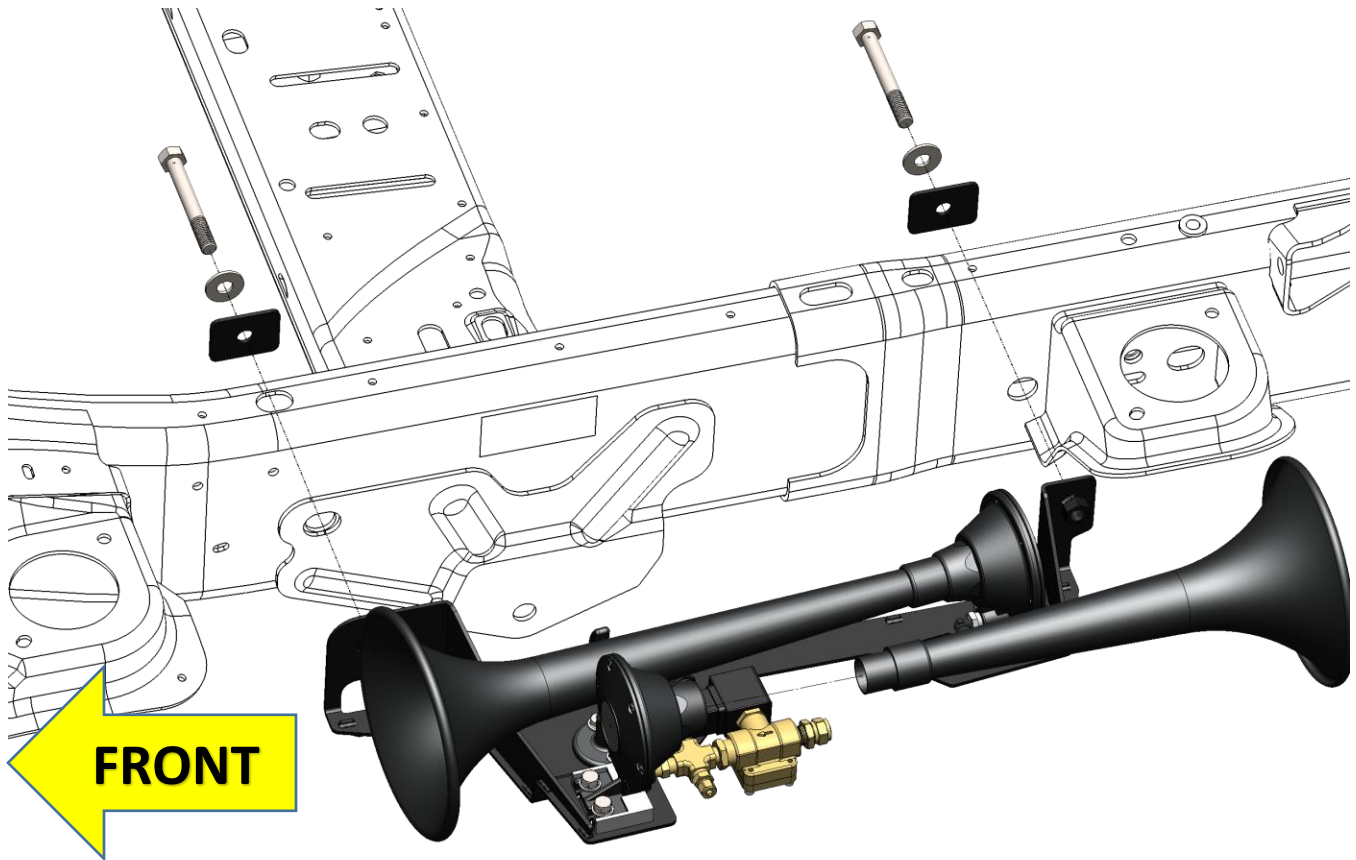

Crew Cab and Mega Cab Orientation (734KIT Shown)

2. Position bracket properly and tighten fasteners, per below illustration.
 - a. Move bracket up-down, and fore-aft, as necessary to **ensure adequate clearance between all trumpets and underbody**
 - i. Large Horn Trumpet must have minimum 1/4" (i.e., thickness of Bic Pen) clearance between underbody floor brace.
 - ii. Horns can also be repositioned on bracket slots.
 - b. Hold bracket in correct position and tighten mounting fasteners firmly
 - c. Tighten horn mounting fasteners to bracket firmly

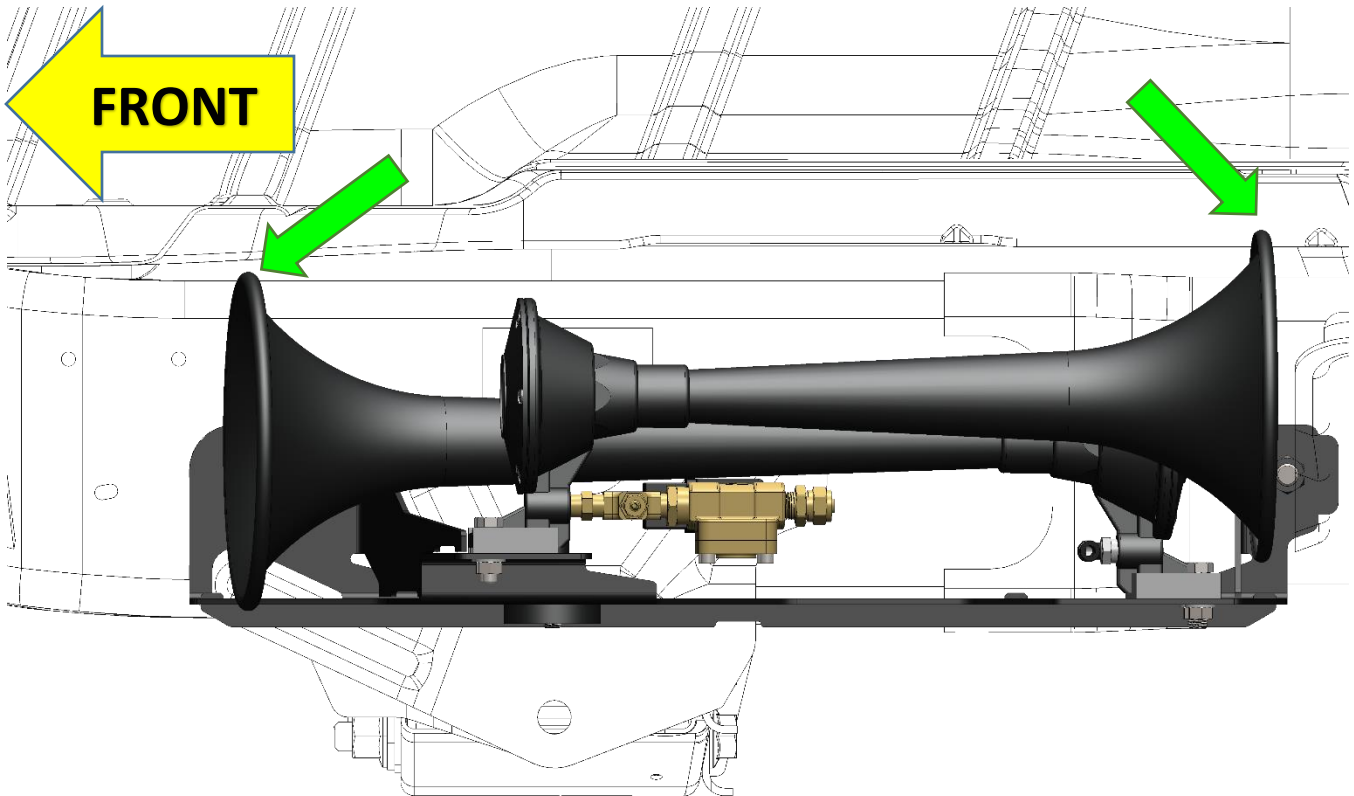

Crew Cab and Mega Cab Orientation (734KIT Shown)

8.2 Small Horn Assembly Installation

1. Attach Small Horn bracket assembly onto vehicle chassis, per below illustration.
 - a. Use RAMHD Hardware kit and finger tighten fasteners only.
 - b. Install Small trumpet into open driver and tighten firmly.

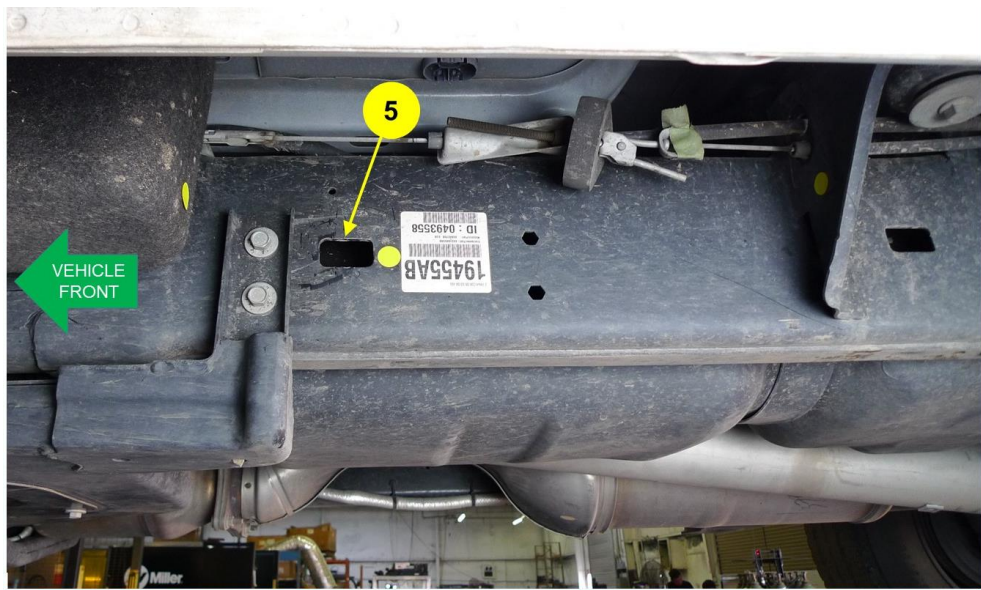

Crew Cab Orientation

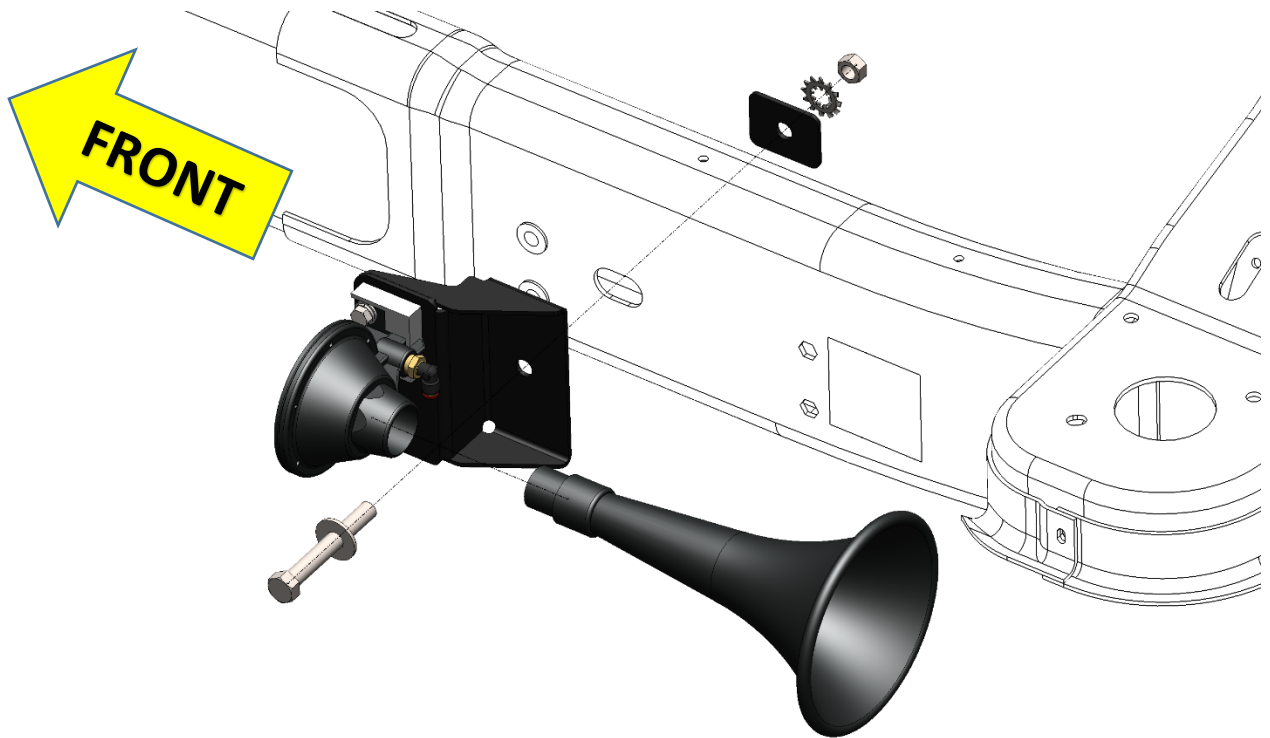

Crew Cab Orientation (734KIT Shown)

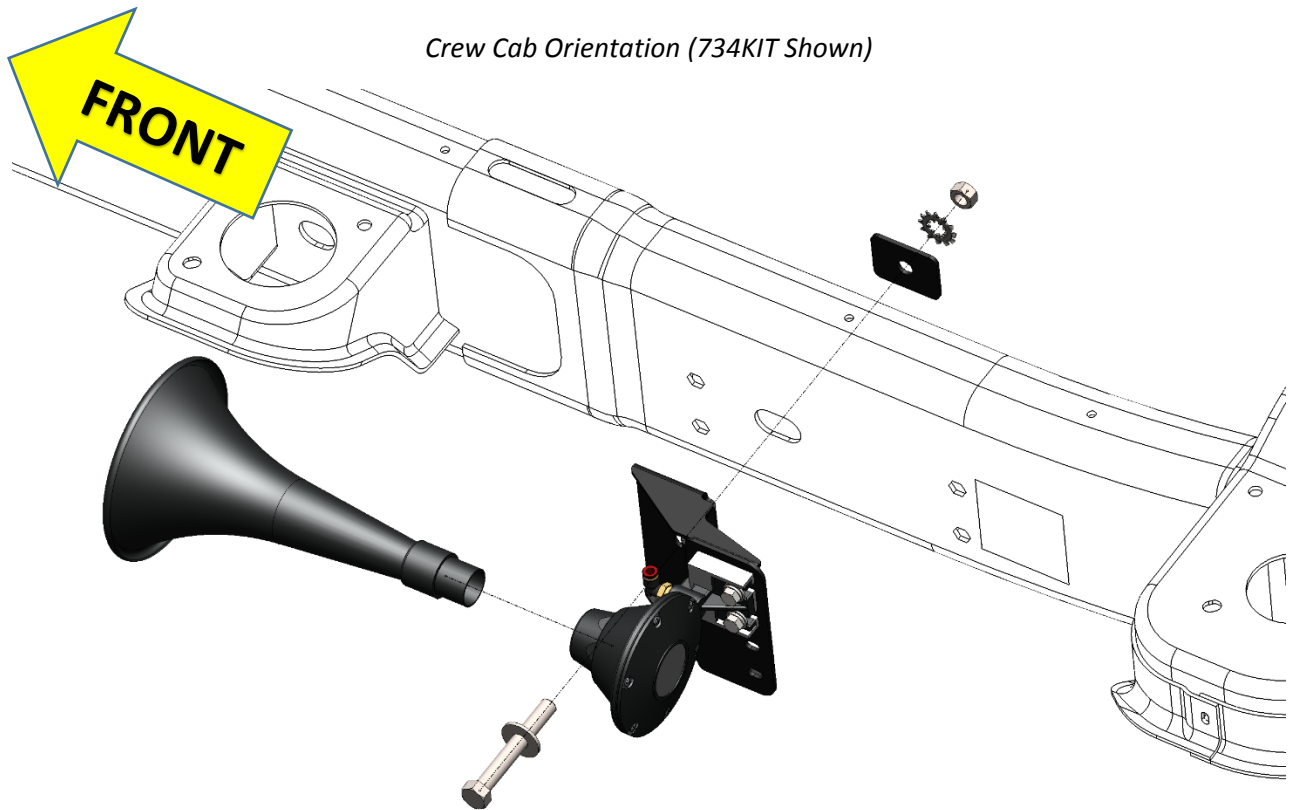

Mega Cab Orientation (734KIT Shown)

RAMHD-230/734KIT

Installation and Operation Manual

2. Position bracket properly and tighten fasteners, per below illustration.
 - a. Move bracket up-down, and fore-aft, as necessary to ensure adequate clearance between trumpet and underbody
 - i. Horn can also be repositioned on bracket slots.
 - b. Hold bracket in correct position and tighten mounting fasteners firmly
 - c. Tighten horn mounting fasteners to bracket firmly

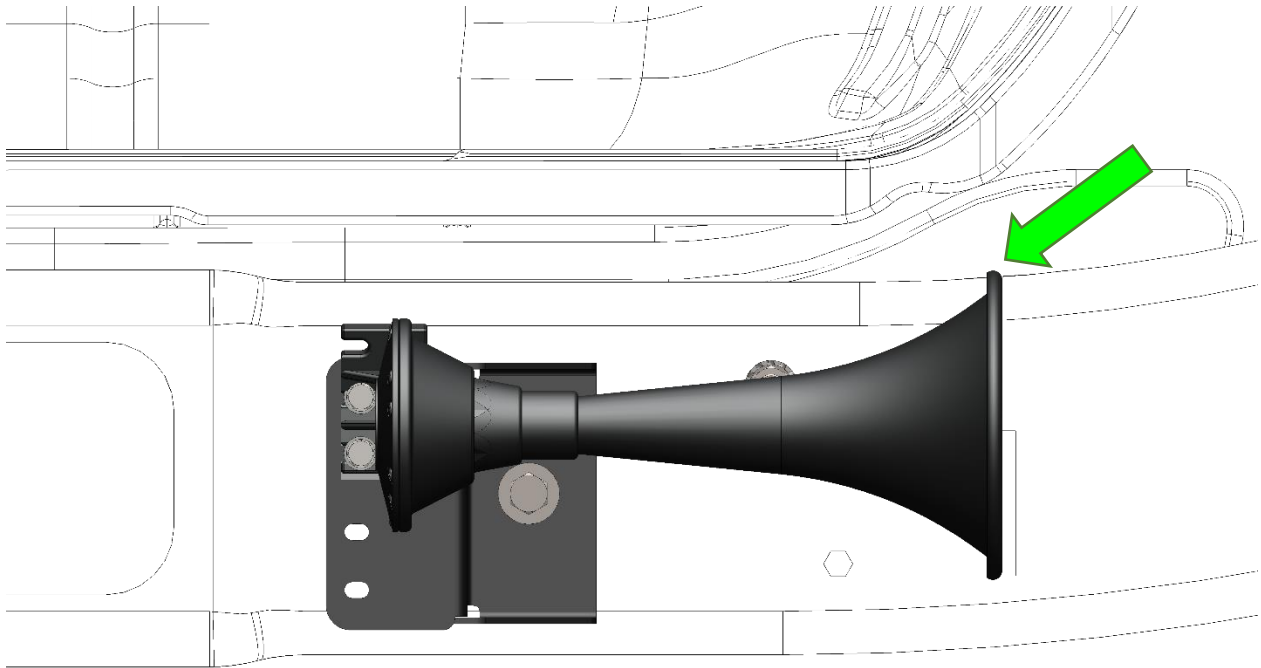

Crew Cab Orientation (734KIT Shown)

8.3 Air Tank Assembly Installation

WARNING: Installing air tank onto vehicle chassis requires hands to be near exhaust system; make sure vehicle exhaust is cool enough to touch before installation.

1. Attach Air Tank assembly onto vehicle chassis, per below illustration.
 - a. Use RAMHD Hardware kit.
 - i. Ensure bracket is sitting entirely flush on chassis and finger tighten fasteners

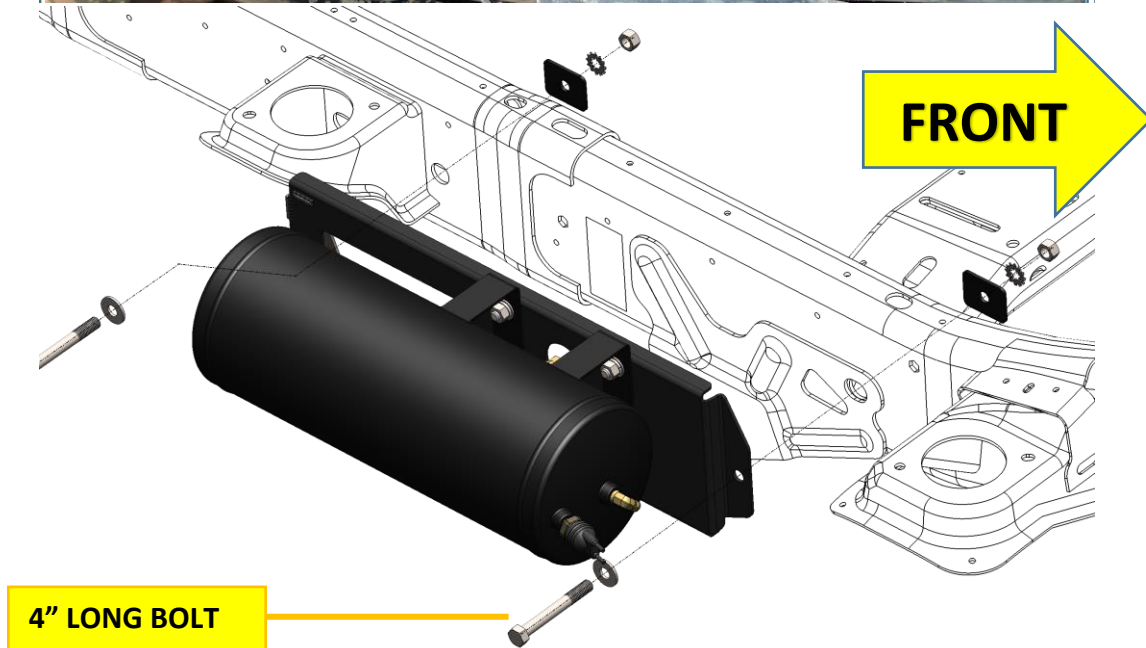
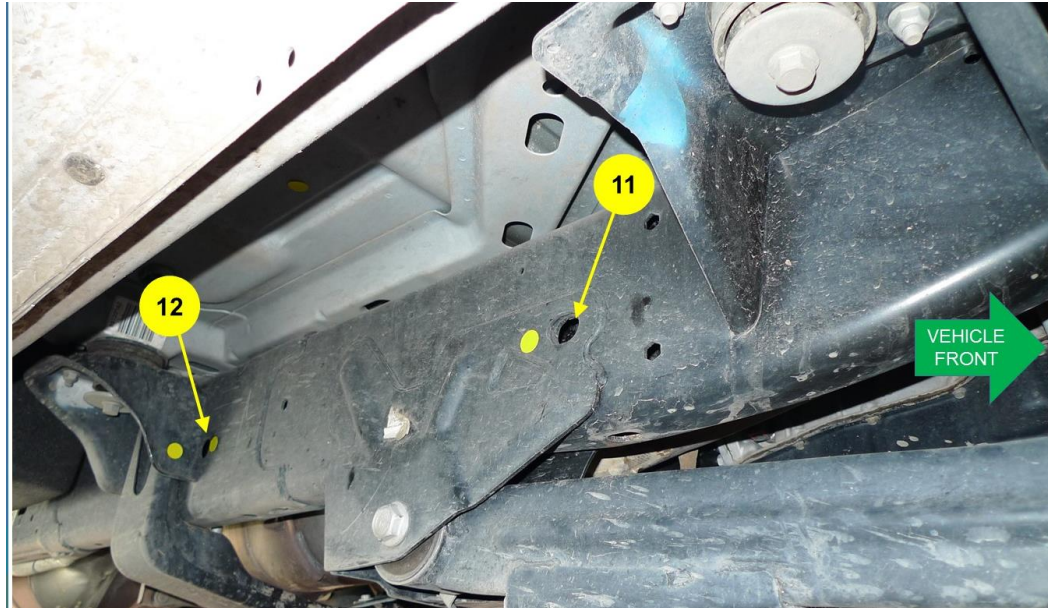

Crew Cab and Mega Cab Orientation (734KIT Shown)

RAMHD-230/734KIT

Installation and Operation Manual

2. Position Air Tank Bracket and Air Tank properly and mark location, per below illustration.

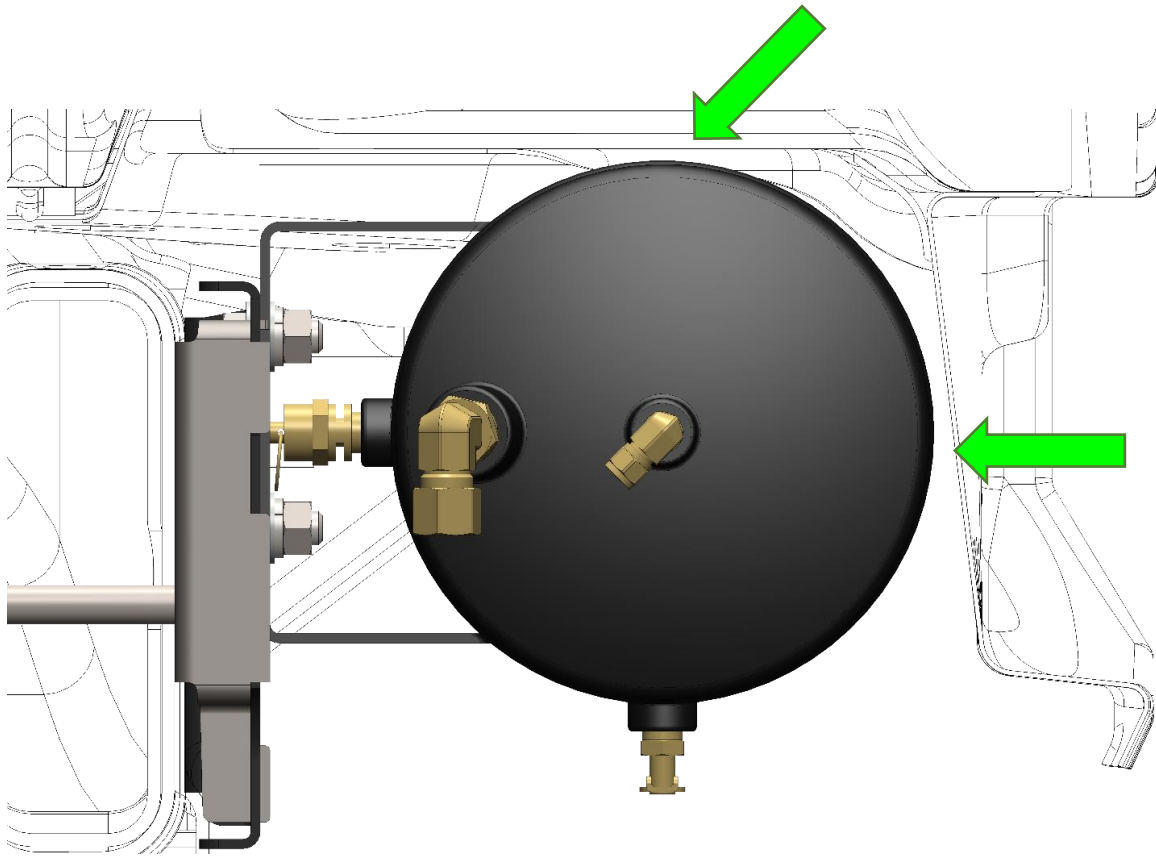

Crew Cab and Mega Cab Orientation (734KIT Shown)

- a. Move bracket up/down, and fore/aft, as necessary to ensure adequate clearance around tank
 - ii. **Air Tank must have minimum 1/4" clearance between underbody and rocker panels**
 - iii. Reposition Tank up/down on bracket slots, if necessary
 - b. Mark proper location of Air Tank on Bracket using grease pencil, or similar
3. Remove Air Tank Bracket from chassis and firmly tighten Air Tank to Bracket mounting bolts
 - a. Use alignment marks made in previous step
 4. Re-install Air Tank Bracket to chassis and firmly tighten mounting bolts to chassis
 - a. Ensure proper clearance between Air Tank and underbody and rocker panels.

8.4 Compressor and Bracket Installation

1. Attach Compressor bracket onto vehicle chassis, per below illustration.
 - a. Use RAMHD Hardware kit.
 - i. Ensure bracket is parallel to frame (i.e., level).
 - ii. Hold bracket in position and firmly tighten fasteners.

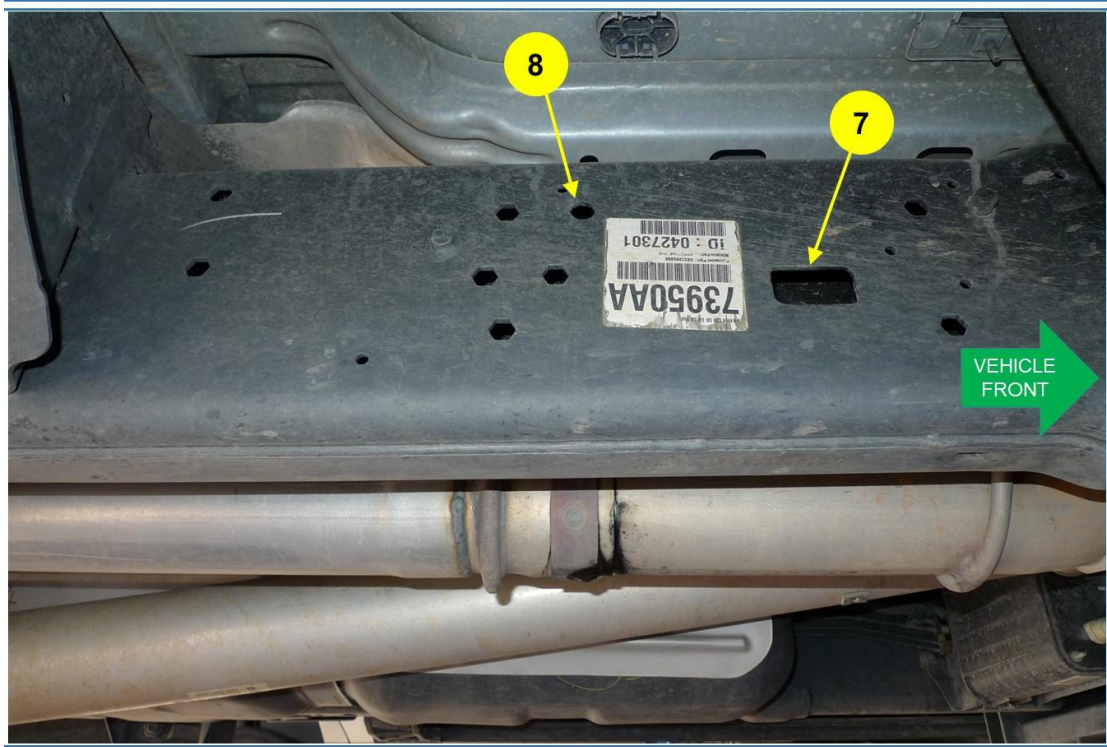

Crew Cab Orientation

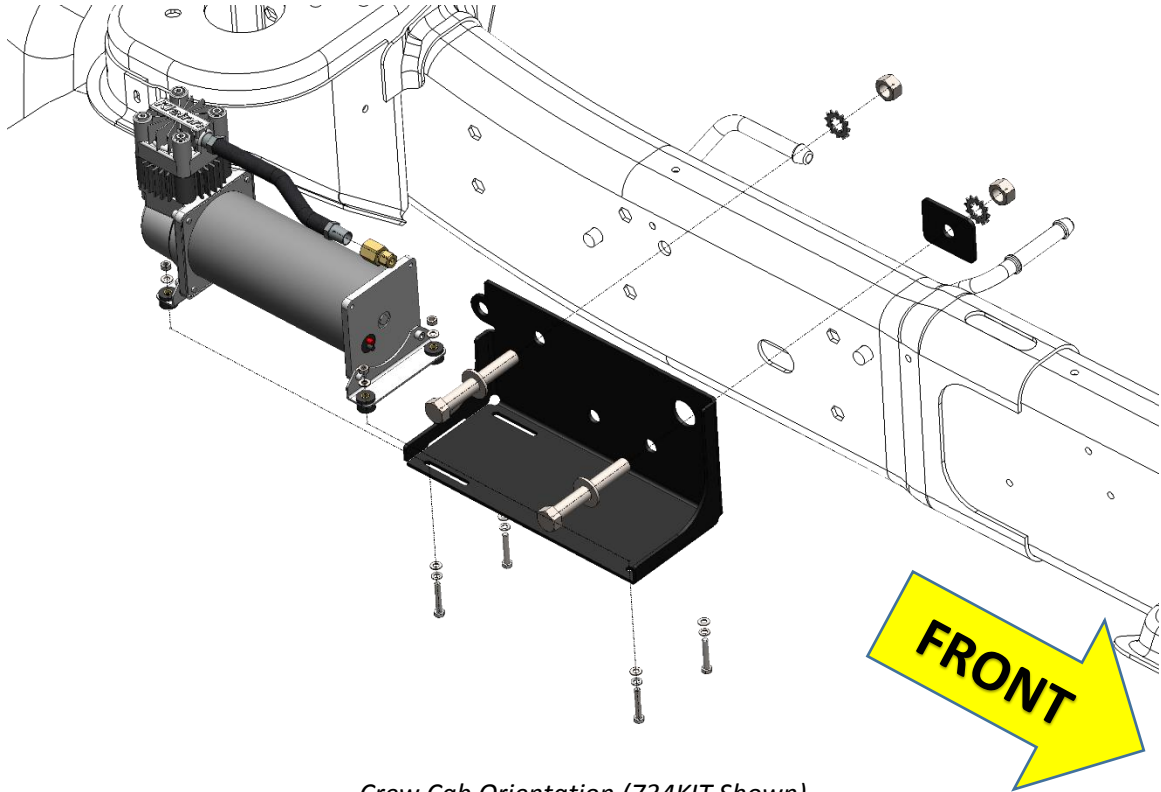

Crew Cab Orientation (734KIT Shown)

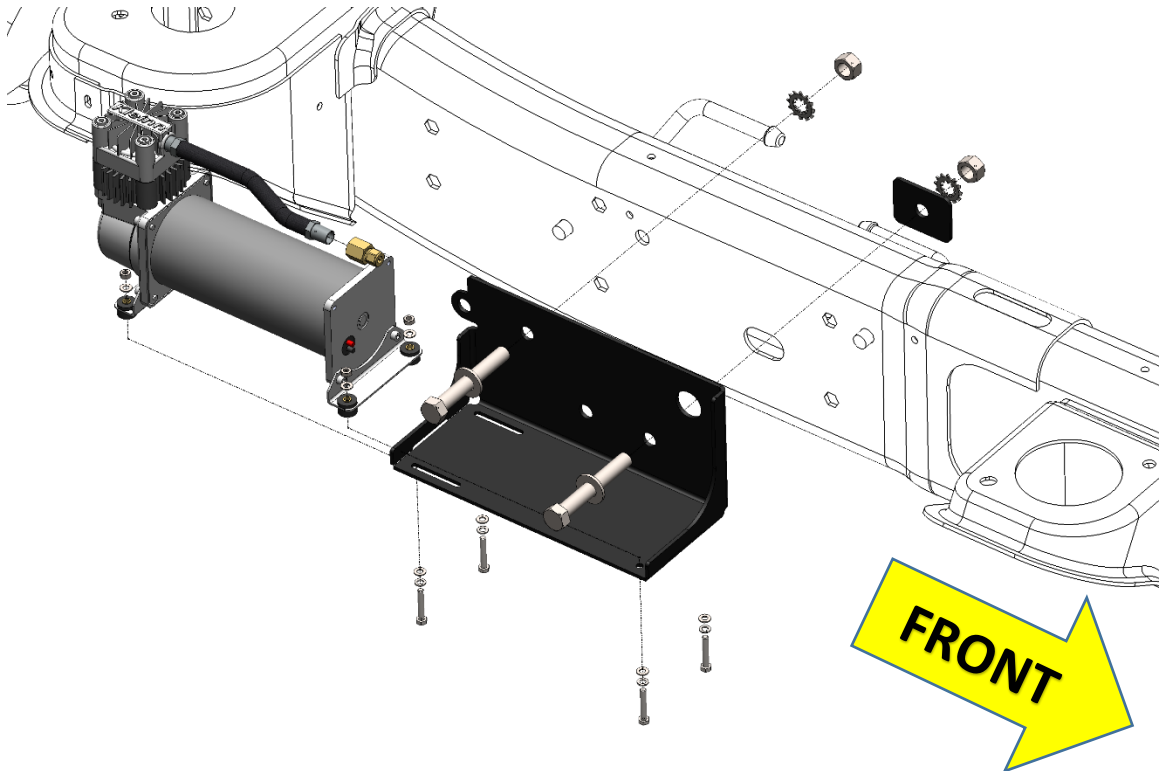

Mega Cab Orientation (734KIT Shown)



RAMHD-230/734KIT

Installation and Operation Manual

2. Attach Compressor to bracket, per above illustration.
 - b. Use included fasteners.
 - i. Tighten fasteners firmly.
3. Attach 51414F 1/4" female compression fitting to end of air compressor hose, per above illustration
 - c. Apply two small drops of [Kleinn Air Horn Juice](#) to each male pipe thread.
 - d. Hand-tighten each fitting, then further tighten each 1/4-1/2 turn using proper sized box-end wrench; top plug requires hex wrench.

9. On Vehicle Air Line Installation

1. Use supplied air tubing and route throughout vehicle, as desired.
 - a. Ensure tubing is away from all sharp edges, hot vehicle parts (i.e., exhaust, engine, radiator), and fasten securely to vehicle using zip ties, or equivalent.
2. Connect air compressor outlet to air tank using supplied 1/4" tubing, per below illustration

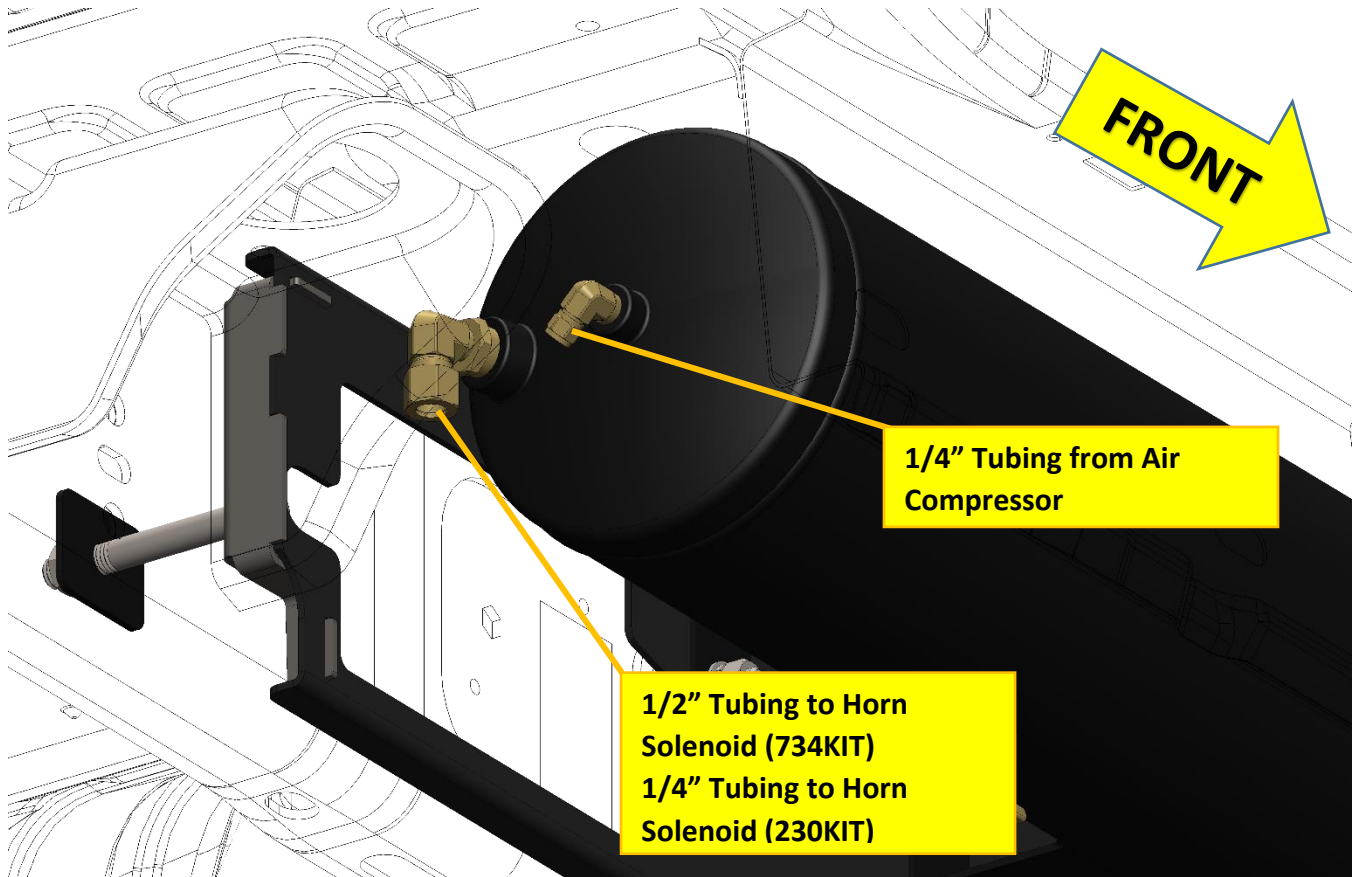

(734KIT Shown)

3. Connect Medium Air Horn solenoid to air tank outlet using supplied 1/2" tubing (734KIT), or 1/4" tubing (230KIT)
4. Connect Remote Quick Connect kit to air tank outlet, per below illustration
 - a. Route and attach Quick Connect Coupler Kit to vehicle, as desired (i.e., under hood, near grill, behind bumper, etc.)

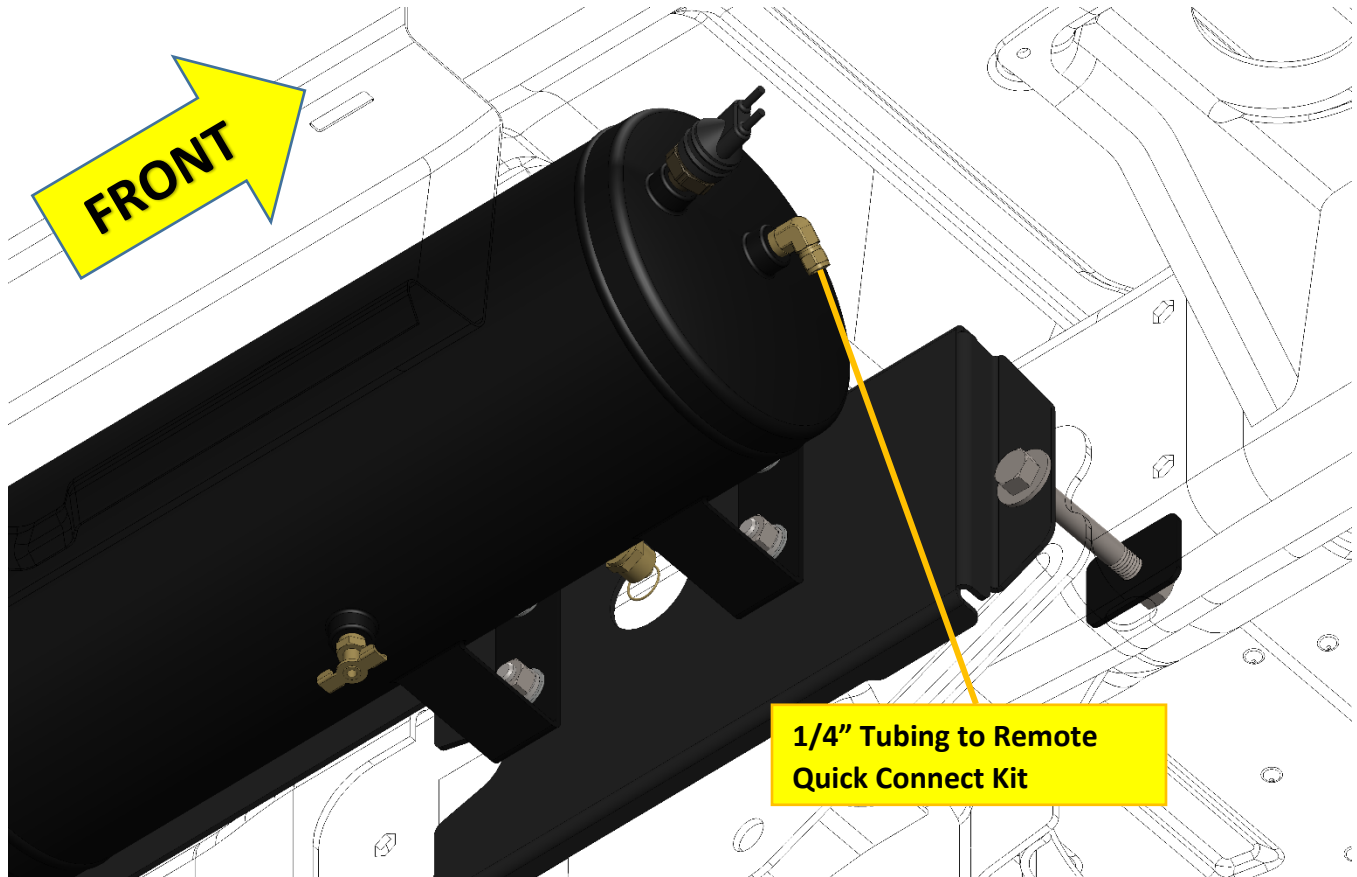

5. Connect remote air compressor filter kit (included with compressor) and route, as desired
 - a. Ensure filter is installed in location away from road spray, water, excessive dust, etc.



6. Re-connect all horns using supplied 1/4" tubing, per below illustration
 - a. Cut all tubing to length using sharp utility blade, razor blade, tubing cutter, or equivalent; ends must be square and not deformed before attaching to air fittings.
 - i. For further instruction on properly installing into fittings, reference this [SMC Video](#)

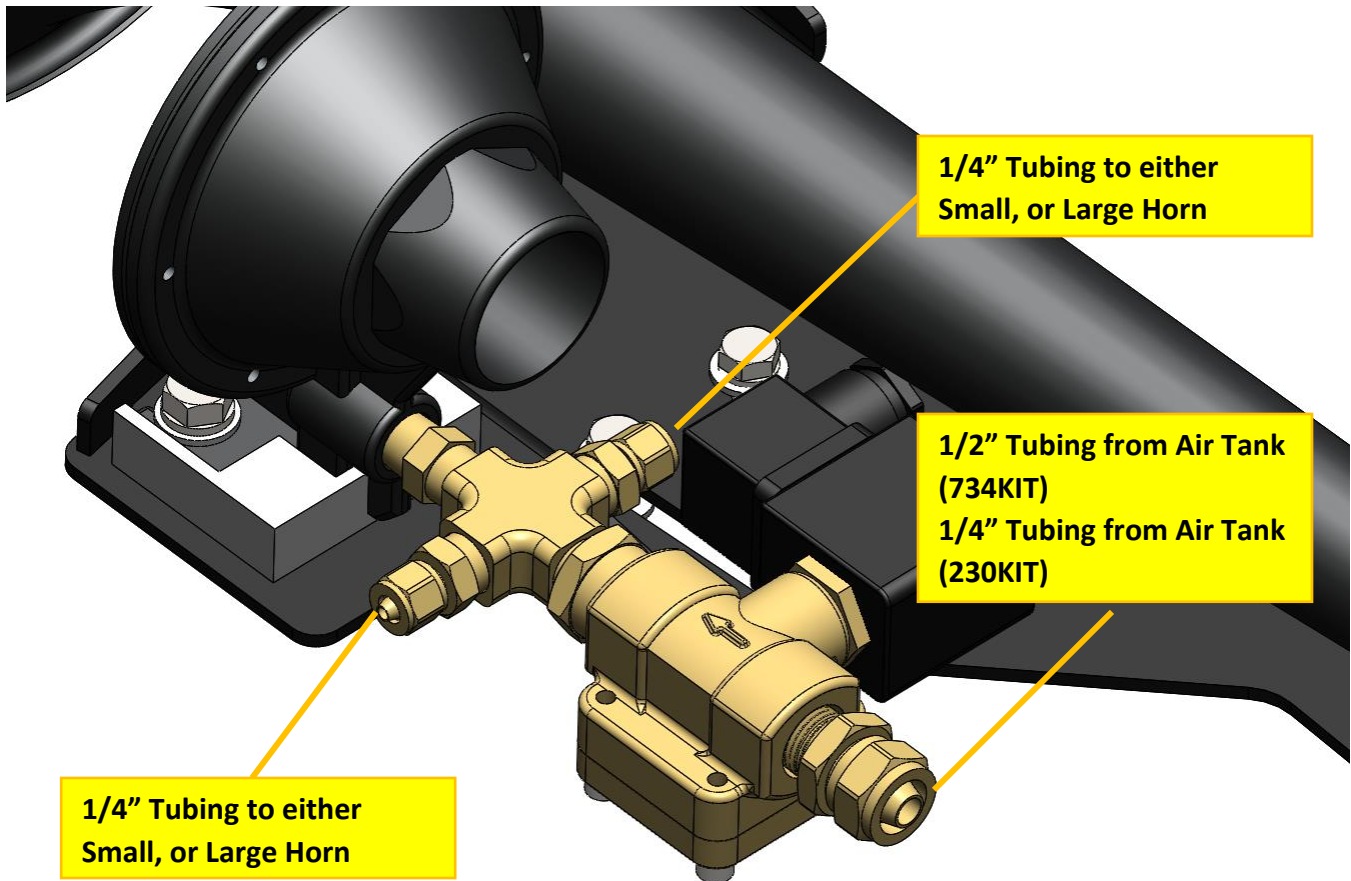

7. View this general [Kleinn 6450RC installation manual](#) for more information
8. View this general [Kleinn 730 Horn Kit installation manual](#) for more information



RAMHD-230/734KIT

Installation and Operation Manual

10. On-Vehicle Electrical Installation

10.1. Disconnect Vehicle Battery(s)

CAUTION: Follow all recommended safety precautions for working on vehicle's electrical system; consult vehicle owner's manual for further instruction.

10.2. Attach Relay to Vehicle

- a. The supplied relay is pre-wired so that it can be installed in line with main power wire. Before cutting any wires, determine adequate placement of relay, and wire accordingly.
 - i. Under hood near battery is always recommended, but final placement is at discretion of end user.
 - ii. Mount relay to vehicle using supplied self-tapping screws.
- b. Connect Pin #87 to compressor's Red power wire, using supplied large Yellow female crimp connector. Wire should be routed down passenger side frame rail away from all exhaust, for later connection to compressor.
- c. Connect Pin #85 to supplied 18-gauge black wire (12-18 inches in length), and attach to adequate vehicle, or chassis ground, using supplied small blue ring terminal and self-tapping screw.
- d. Connect Pin #86 to supplied Yellow wire and route to pressure switch wire on Air Tank (either wire can be connected). Connect remaining yellow wire to other wire on pressure switch, route to vehicle interior, and connect it to a fused, 12v switched power source (i.e., open accessory spot on fuse block).

10.3. Route Wiring and Install Horn Button

- a. Locate red 10-gauge power wire, this wire will be run to battery and down to compressor bracket. Wire should be routed down passenger side frame rail away from all exhaust, for later connection to compressor; however, installer may route as desired.
 - i. Install supplied fuse holder on end of power wire by cutting the loop in fuse holder and connecting supplied Ring terminal to one end and butt connector on other end. Connect butt connector to red power wire and crimp properly.

CAUTION: Do not install 30-amp fuse provided until all electrical connections are final.

- ii. Connect ring terminal to positive terminal of battery; if multiple batteries exist on vehicle, it's recommended to attach to secondary battery.
 - iii. Route wire through 1/4" supplied split loom.

NOTE: Do not cut wires to length until you are 100% sure of length required for final connections.

- b. Route yellow and purple wires from horn and ignition switch through a grommet in cab floor; user preference on grommet to use, based on selected route of wiring.
 - c. Find a suitable location for horn pushbutton (i.e., in dash, center console, etc.) and drill a 3/4" hole. Run purple wire from behind and through hole along with supplied section of 18-gauge red wire. Slide

pushbutton retaining nut over both wires, then connect purple wire to one terminal of pushbutton and red wire to other terminal. Install pushbutton into drilled hole and tighten nut on backside securely.

- d. Route 18-gauge red wire to a fused power source and connect.
- e. Insert all wiring into included wire loom and ensure loom is away from all sharp edges, hot vehicle parts (i.e., exhaust, engine, radiator), and fasten securely to vehicle using zip ties, or equivalent.

REFERENCE: View these general [Kleinn Horn Button Install Manual](#), and [Kleinn Factory Horn Button Manual](#) for additional information

10.4. Connect Relay to Wiring

- a. Connect Pin #87 to compressor's Red power wire, using supplied large Yellow female crimp connector.
- b. Connect Pin #85 to supplied 18-gauge black wire (12-18 inches in length), and attach to adequate vehicle, or chassis ground, using supplied small blue ring terminal and self-tapping screw. Ensure ring terminal is properly grounded by either touching bare metal, or via self-tapping screw.
- c. Connect Pin #86 to supplied Yellow wire and to pressure switch wire on Air Tank (either wire can be connected). Connect remaining yellow wire to other wire on pressure switch, route to vehicle interior, and connect it to a fused, 12v switched power source (i.e., open accessory spot on fuse block).

10.5. Connect Air Horn Solenoid

- a. Remove single screw holding black plastic protective housing from solenoid and insert end of long purple wire and short black wire into round port on housing; fasten wires to solenoid screws, per below illustration

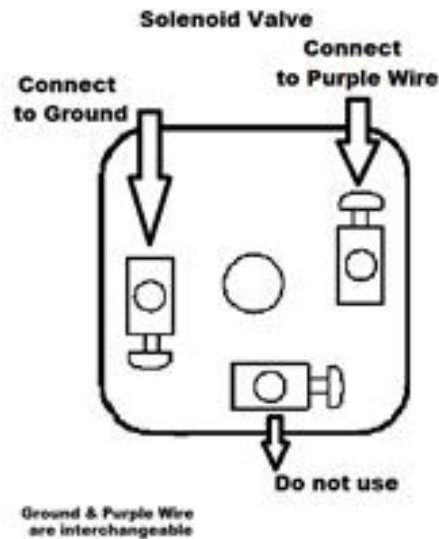

- b. Black ground wire from solenoid can be trimmed to length, and small blue ring terminal crimped on, it can then be attached to a paint free surface (i.e., grounded), with supplied self-tapping screw.
- c. Purple wire can be routed down frame rail and into vehicle interior; it will later be attached to horn activation button.
- d. Install supplied 30-amp fuse into inline fuse holder

10.6. Reconnect Vehicle Battery(s)

CAUTION: Before connecting vehicle battery(s), verify all wiring is properly connected and no shorts exists. Use of Multi-Meter, or Test Light is recommended to check continuity of all connections.



RAMHD-230/734KIT

Installation and Operation Manual

11. Initial Testing of Kit

11.1. Test Air Compressor

- a. Turn vehicle ignition to on position and allow compressor to fill Air Tank. Initial fill may take approximately 1.5-3 minutes; Air Compressor should shut off automatically once full pressure is achieved.
- b. If compressor runs excessively (i.e., 5 minutes or more), disconnect electrical power to Air Compressor and listen for air leaks in system. Repair any problems and retest; contact Kleinn technical support if problem persists.
- c. Inspect all air line connections (i.e., Air Tank fittings, Quick Connect fittings, Air Horn fittings, etc.) for leaks by using a soap and water solution sprayed directly onto fittings
 - a. System must be pressurized or at least Air Compressor running
- d. If an air leak is found:
 - a. Safely release air pressure from system (i.e., slowly open drain valve)
 - b. Disassemble leaky connection, re-seal and reinstall fittings as needed

11.2. Test Train Horns

- a. Allow Air Compressor to run and shut-off automatically (i.e., Air Tank is full)
- b. Verify all tubing and electrical wire is securely fastened to vehicle, brackets, or kit parts; if necessary, use extra zip ties to hold tubing and wire in place
- c. Ensure all nearby persons have adequate hearing protection and provide courtesy warning to neighbors or others in vicinity

WARNING: NEVER operate train horns with ears close to trumpets or in an enclosed space without [substantial hearing protection](#) (i.e., > Ear Plugs and Ear Muffs) for all persons closer than 100 feet from vehicle. Never operate train horns outdoors when persons are near vehicle without adequate hearing protection.

- a. Briefly activate Horns by pressing Horn Button for one (1) second; repeat three (3) times with a short rest period between (i.e., 1-3 seconds)
 - i. Horns should sound as expected and be loud; [click to listen to example 230 Kit](#)
 - ii. Horn sound/loudness will taper quickly as Air Tank loses pressure
- b. Allow Air Compressor to refill tank, if needed and activate Horns for longer three (3) second period to ensure Horns are functioning properly.

11.3. Test Quick Connect Coupler

- a. Allow Air Compressor to refill tank, if needed
- b. Attach supplied INF-1 inflator kit to Quick Connect Coupler and verify adequate air pressure is available
 - i. Test fill tires on vehicle, bicycle, etc.
 - ii. Use Air Blow Gun
 - iii. Use Air Impact Gun



RAMHD-230/734KIT

Installation and Operation Manual

12. General Operation of Kit

12.1. Compressor Operation

WARNING: *Never operate Air Compressor above its MAXIMUM PRESSURE RATING (see label on body). Operation exceeding maximum pressure will damage Air Compressor and may result in DANGEROUS Air System failure.*

- a. Air compressor is equipped with an automatic thermal overload protection circuit, designed to protect air compressor from overheating and causing permanent damage.
- b. Automatic thermal overload protector will automatically reset after 30 minutes.
- c. To prevent discharge of vehicle's battery and for best performance, keep vehicle's engine running while using air compressor for any prolonged use (i.e., filling tires, using air tools, etc.).

12.2. Horn Operation

- a. Allow Air Compressor to run until it shuts off automatically (i.e., Air Tank is full), or for at least one minute in between horn activations.
- b. Press Horn Button to activate Horns
 - i. Horn sound/loudness will taper quickly as Air Tank loses pressure.
 - ii. Horns should sound for 3-7 seconds depending on kit and tank size

WARNING: *NEVER operate train horns with ears close to trumpets or in an enclosed space without substantial hearing protection (i.e., > Ear Plugs and Ear Muffs) for all persons closer than 100 feet from vehicle. Never operate train horns outdoors when persons are near vehicle without adequate hearing protection.*

13. Routine Maintenance

Perform following steps at least once during recommended intervals.

1. Yearly, or every 12000 miles verify all mounting fasteners are properly torqued; applying witness marks across fasteners and mounting parts is good practice to quickly ensure fasteners have not moved.



2. Yearly, or every 12000 miles remove all road grime and mud from mounting brackets and kit parts using clean water from a garden hose; pay special attention to corners where dirt may collect. Touch up all paint chips using automotive grade enamel in either spray, or brush form.

NOTE high pressure washers may damage part finishes and must be used with care. Do this more frequently if traveling regularly off-road, or in winter climates where road salts are used.

3. Yearly, or every 12000 miles check electrical and air fitting connections and wires for abrasion, corrosion, or other damage. Replace damaged components.

NOTE: if system runs continuously or turns on unexpectedly, leaks or intermittent electrical connection may be present.

4. Monthly, or every 10 hours of compressor run time, drain moisture from air tank using drain valve installed at bottom of tank.

WARNING: Failure to regularly drain air tank may result in corrosion inside tank and possible failure in tank or air lines, which can suddenly release air pressure causing injury to nearby people.

5. Yearly, or every 12000 miles clean, or replace air compressor air filter element. Replacement frequency depends on operating frequency and conditions of operating environment (i.e., daily use of air compressor in dusty, or wet environment requires more frequent filter change). Order replacement filters at Kleinn.com.

NOTE: Never lubricate or add any liquids to the included oil-less air compressor.



RAMHD-230/734KIT

Installation and Operation Manual

14. Warranty Information

Thank you for purchasing this RAMHD-734KIT. Shall you experience any unexpected problems during installation, or have problems with any part at any time please contact Kleinn support.

KLEINN MANUFACTURER LIMITED DEFECT WARRANTY:

Kleinn Automotive Air Horns warrants this product to the end-user, when properly installed and under normal conditions of use, to be free from defects in workmanship and materials for a period of one year from the provided date of purchase, to the original purchaser of the product. This warranty does not cover abuse, operation in a manner inconsistent with the product's design, or damage resulting from exposure to the elements. If the defect is considered "under warranty", Kleinn will, at its option, repair or replace the product free of charge to the original purchaser. Kleinn is not liable for any installation charges, loss or damage of any kind incurred in the replacement or repair of any warranted product.

© Kleinn Air Horns 2018, All rights reserved.

PO Box 91278 Tucson, AZ 85752

Phone: (520) 579-1531

Web: www.Kleinn.com