

1" Spacers are required if running stock Wheels

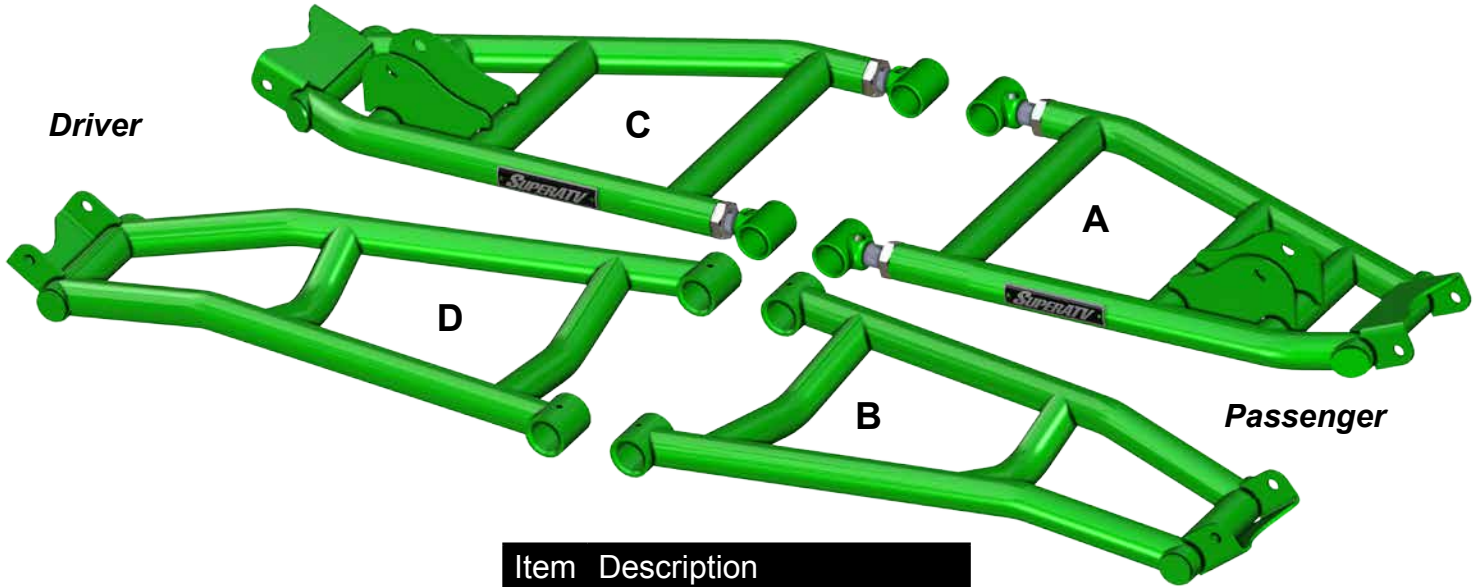

Item	Description
A	Rear Upper Arm (Passenger)
B	Rear Lower Arm (Passenger)
C	Rear Upper Arm (Driver)
D	Rear Lower Arm (Driver)

(kit contents continue on following pages)

Liability Statement

SuperATV's® products are designed to best fit user's ATV/UTV under stock conditions. Adding, modifying, or fabricating any factory or aftermarket parts will void any warranty provided by SuperATV® and is not recommended. SuperATV's® products could interfere with other aftermarket accessories. If user has aftermarket products on machine, contact SuperATV® to verify that they will work together.

Although SuperATV® has thousands of satisfied customers, user should be aware that installing lift kits, long travel, or suspension kits, tires, etc. will change the ride of machine and may increase maintenance and part wear. Operating any off-road machine while, or after, consuming alcohol and/or drugs increases risk of bodily harm or death. No warranty or representation is made as to this product's ability to protect user from severe injury or death. SuperATV® urges operators and occupants to wear a helmet and appropriate riding gear at all times.

By purchasing and installing SuperATV® products, user agrees that should damages occur, SuperATV® will not be held responsible for loss of time, use, labor fees, replacement parts, or freight charges. SuperATV®, nor any 3rd party, will not be held responsible for any direct, indirect, incidental, special, or consequential damages that result from any product purchased from SuperATV®. The total liability of seller to user for all damages, losses, and causes of action, if any, shall not exceed the total purchase price paid for the product that gave rise to the claim.

SuperATV® will warranty only parts provided by SuperATV®. Any damage or problems with OEM housings, bearings, seals, or other manufacturers' products will not be covered by SuperATV®. SuperATV® parts and products are not warranted if item was not installed properly, misused, or modified.

Installing, adding, modifying, or fabricating any factory or aftermarket product to your ATV/UTV may violate certain local, state, and federal laws. Be advised that laws vary depending on town, city, county, state, etc. Use of certain products on public streets, roads, or highways may be in violation law. The Buyer is solely and exclusively legally and personally responsible for any violation of the law by the installation or use of the product. You must abide by all local, state, and federal laws, including but not limited to vehicle safety, traffic laws, and ordinances. It is your responsibility to know the laws and how they apply to you.

The Buyer is responsible to fully understand the capability and limitations of his/her vehicle according to manufacturer specifications, warnings and instructions and agrees to hold SuperATV® harmless from any damage resulting from failure to adhere to such specifications, warnings and/ or instructions. The Buyer is also responsible to obey all applicable federal, state, and local laws and ordinances when operating his/her vehicle while using this product, and the Buyer agrees to hold SuperATV® harmless from any violation thereof.

Need help with your installation?

 sales@superatv.com
  www.superatv.com
 1-855-743-3427
  8:00am - 9:00pm EST M-Th
 8:00am - 7:00pm EST Friday
 9:00am - 2:00pm EST Saturday

Read instructions and view illustrations before beginning.

Thank You
For Choosing
SUPERATV.COM[®]

Item	Description
E	Front Upper Arm (<i>Passenger</i>)
F	Front Lower Arm (<i>Passenger</i>)
G	Front Upper Arm (<i>Driver</i>)
H	Front Lower Arm (<i>Driver</i>)

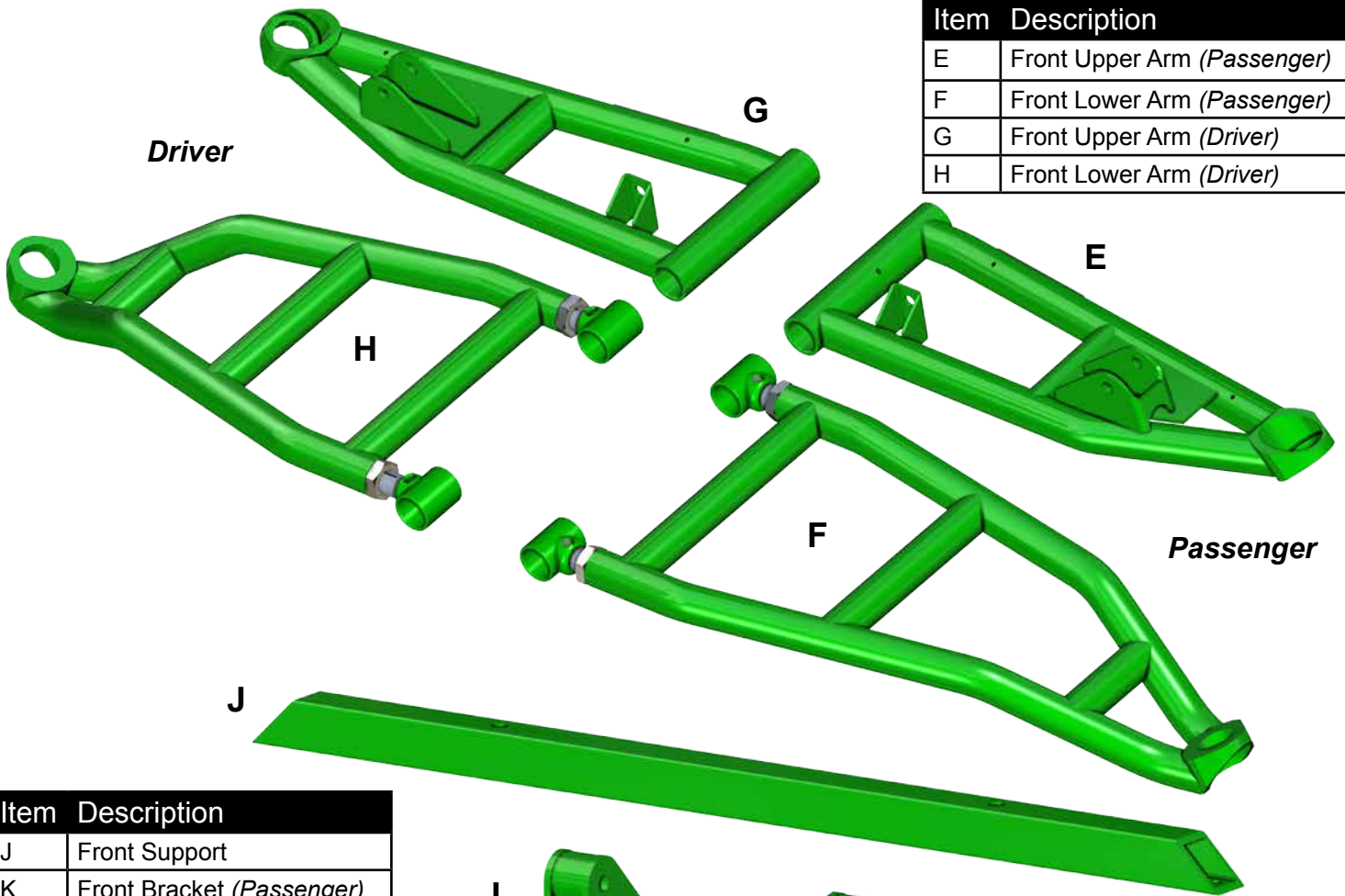

Item	Description
J	Front Support
K	Front Bracket (<i>Passenger</i>)
L	Front Bracket (<i>Driver</i>)
M	Rear Bracket (<i>Driver</i>)
N	Rear Bracket (<i>Passenger</i>)
P	Front Brake Line Assembly

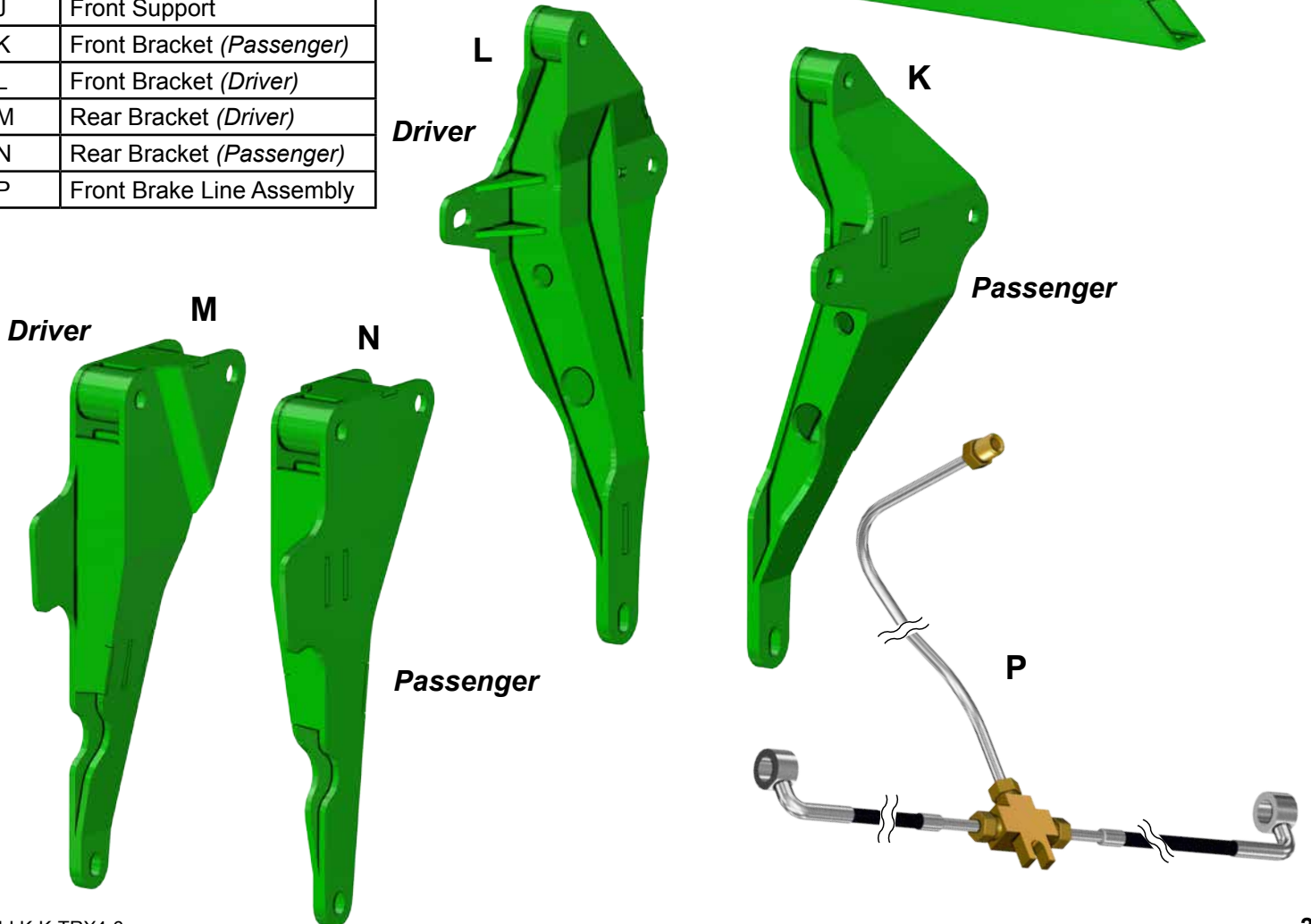

4x  M5-.80 x 16mm Lg. PHMS

2x  M10-1.50 x 60mm Lg. FHCS

2x  M10-1.50 x 60mm Lg. SHCS

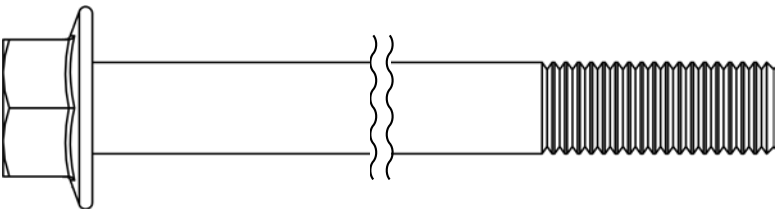
2x  M12-1.75 x 220mm Lg. FHCS

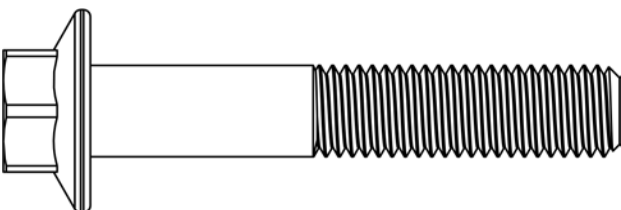
2x  M12-1.75 x 70mm Lg. FHCS

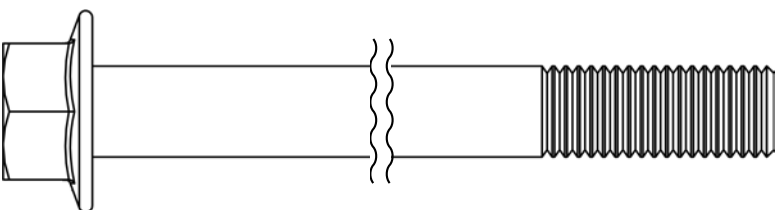
2x  M12-1.75 x 100mm Lg. FHCS

6x  M12-1.75 Nylock Nut

4x  M10-1.50 Nylock Nut

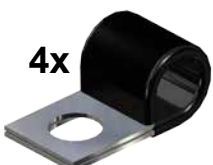
4x 
Brake Line Clip

Steering Stop Kit

10x 
Straight Zerk Fitting

2x 
Cap

4x 
45° Zerk Fitting

Remove FRONT components shown: Keep all components and hardware removed from machine.

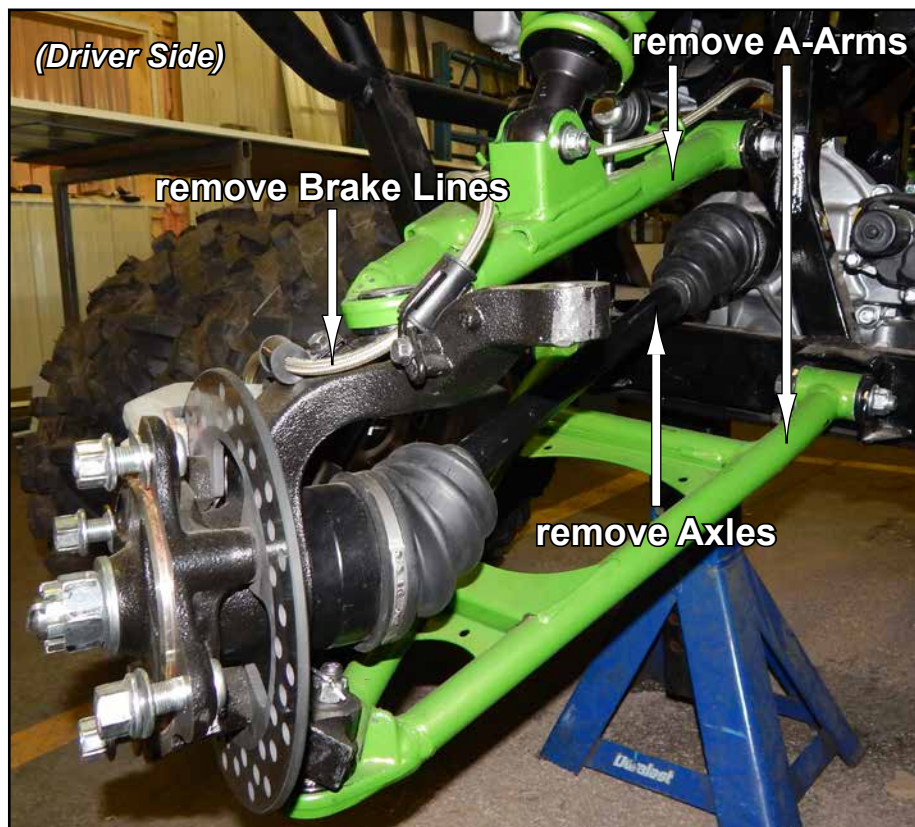
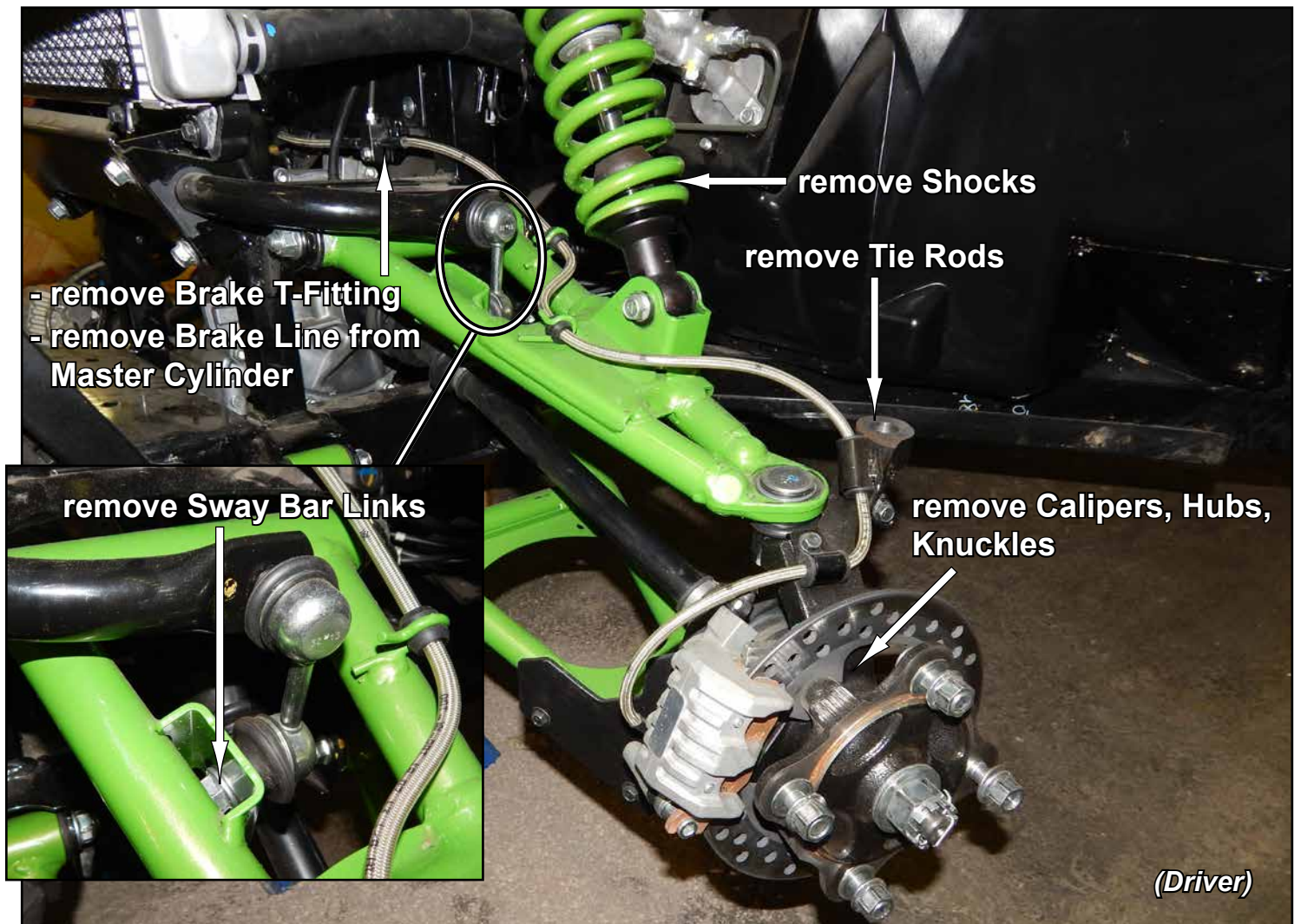

Front A-Arms Prep:

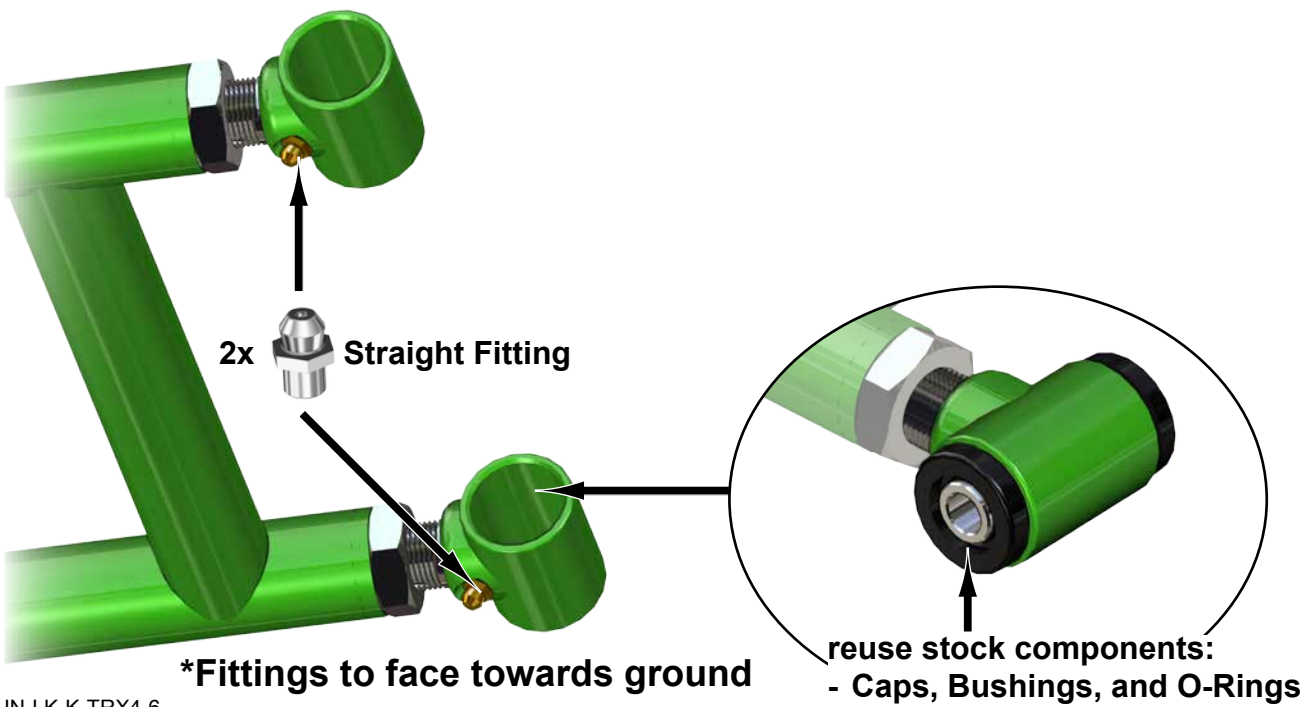
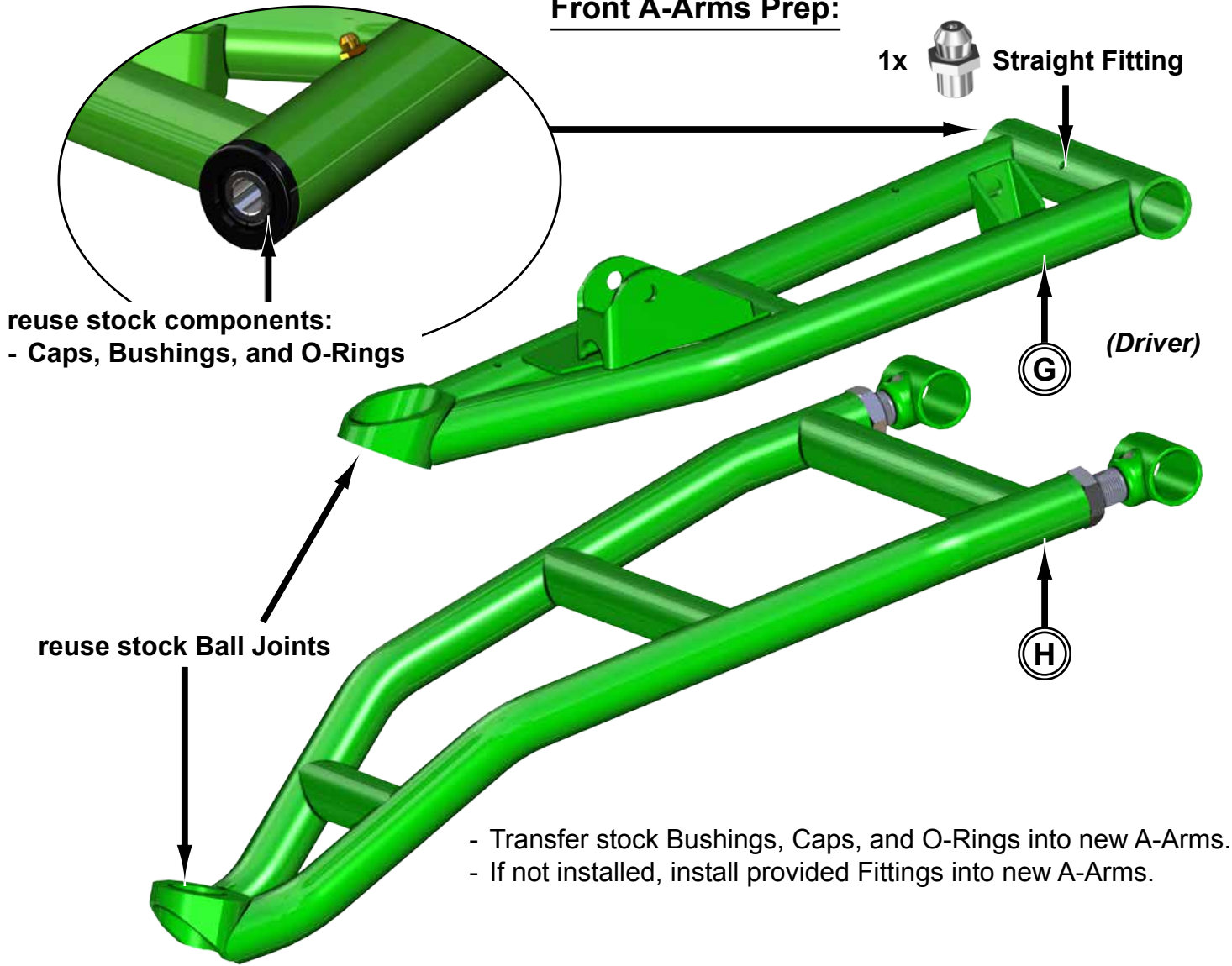

PIVOT BLOCK SETTINGS

- Place new A-Arms onto a flat surface and verify dimension shown.
- *Negative 1° camber setting is achieved when Pivot Blocks are set to this dimension.*
- See last page for additional camber information.

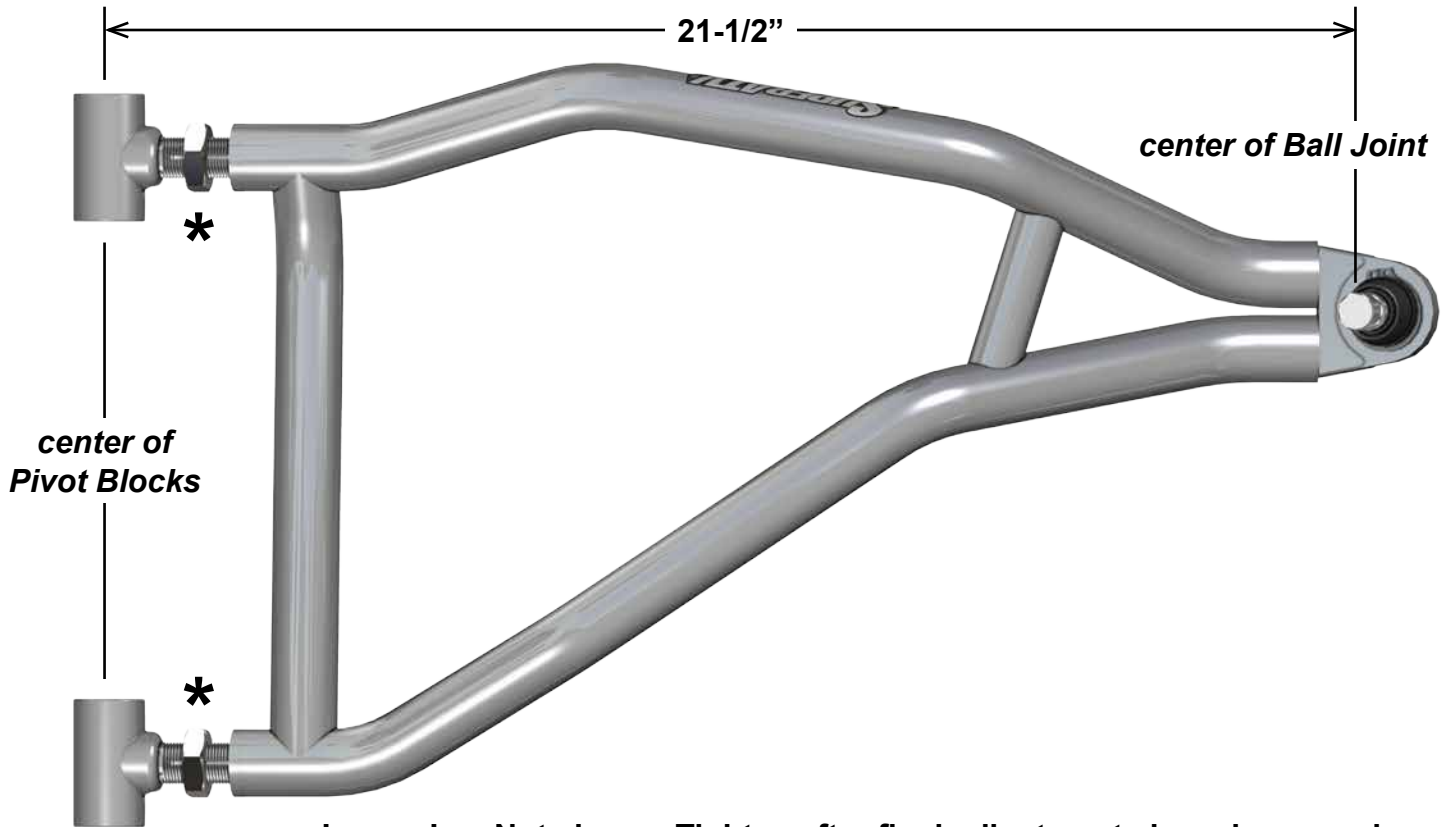

*Leave Jam Nuts loose. Tighten after final adjustments have been made.

Steering Stop Installation:

- Install Steering Stop onto Rack and Pinion shaft; repeat for opposite side.
- Do not install Boots at this time.



Tie Rod Installation: *Rack and Pinion shown off machine for clarity.*

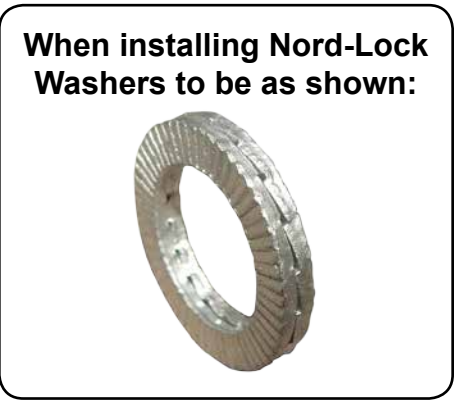

Use provided Loc-Tite on Jam Nuts and locations shown after Toe has been set.

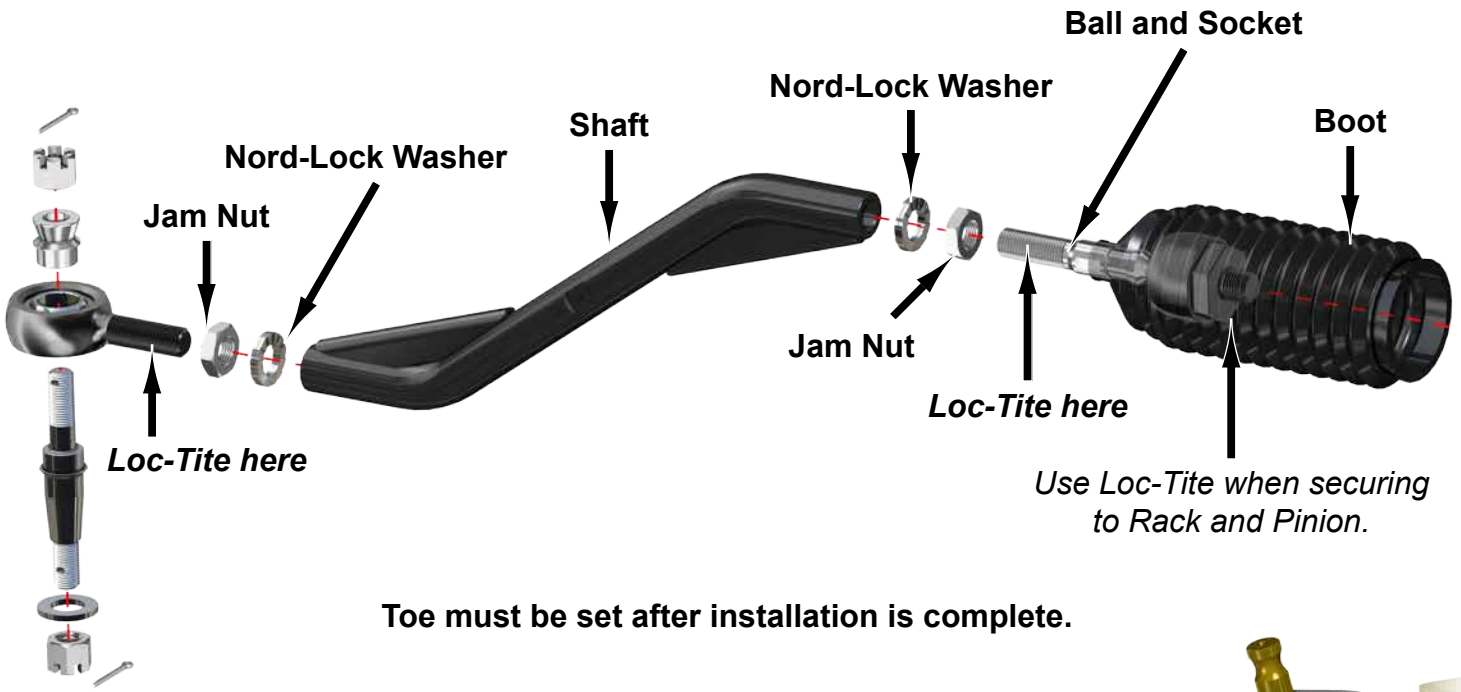

Toe must be set after installation is complete.

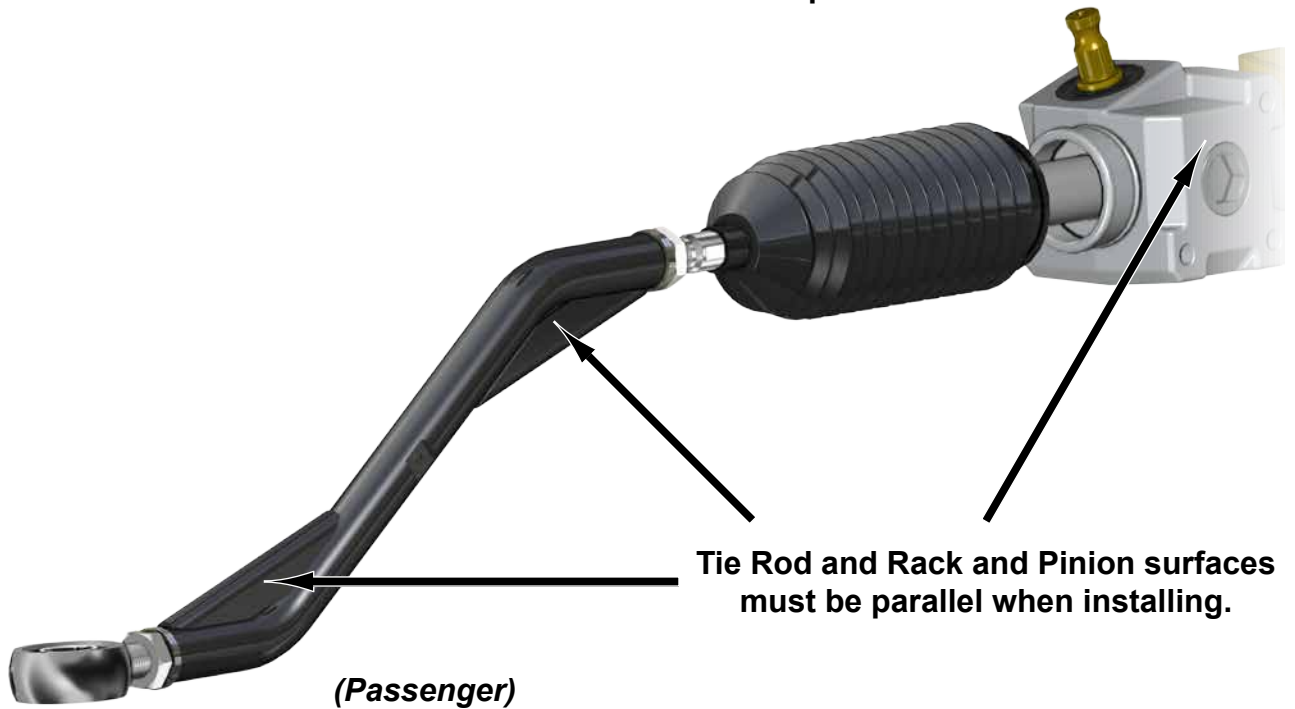

Front Brake Line Assembly (P) installation:

- Secure T-Fitting to stock location with stock hardware.

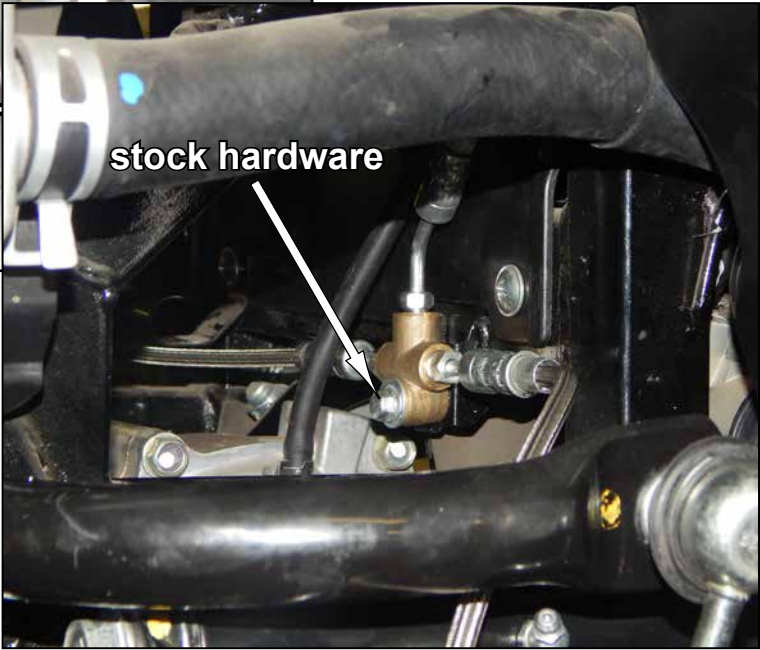
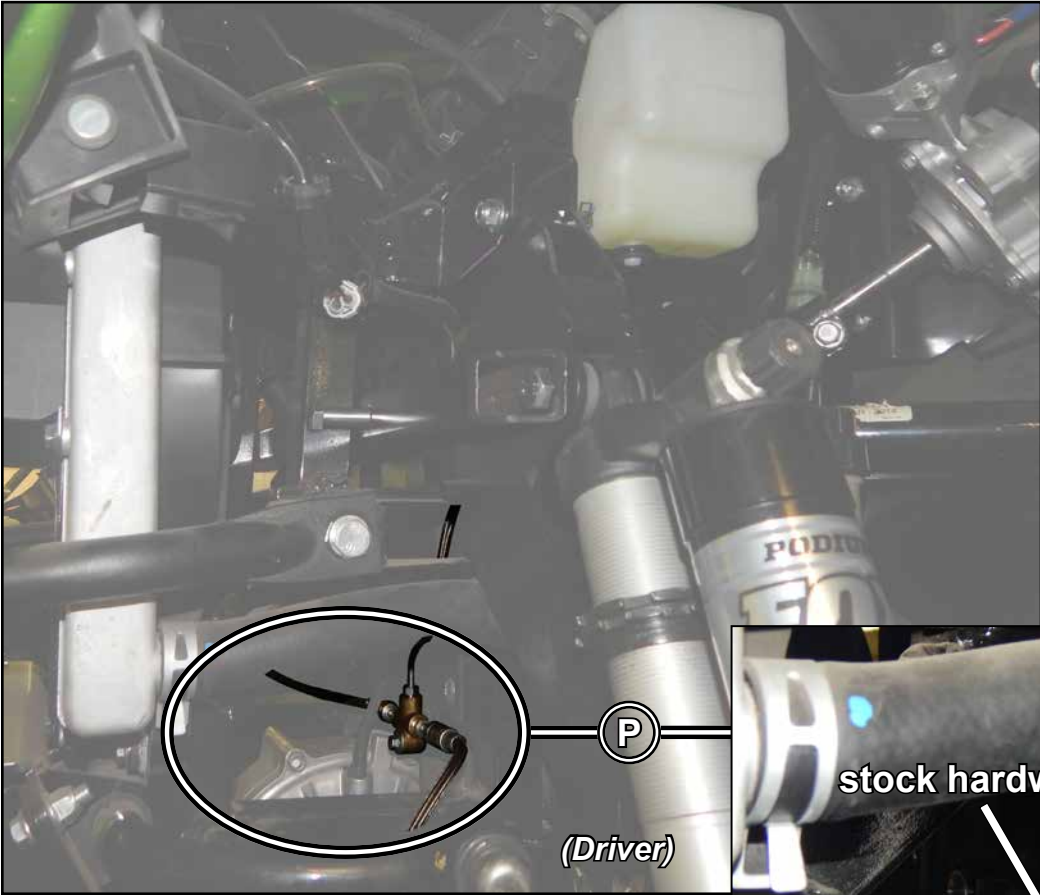

Front installation continued:

- Install Front Support (J) to Front Brackets (K)(L) with hardware shown.
- Secure upper section of Shocks to Front Brackets (K)(L) with hardware shown. *Note: Bolt will go through Front Support (J).*

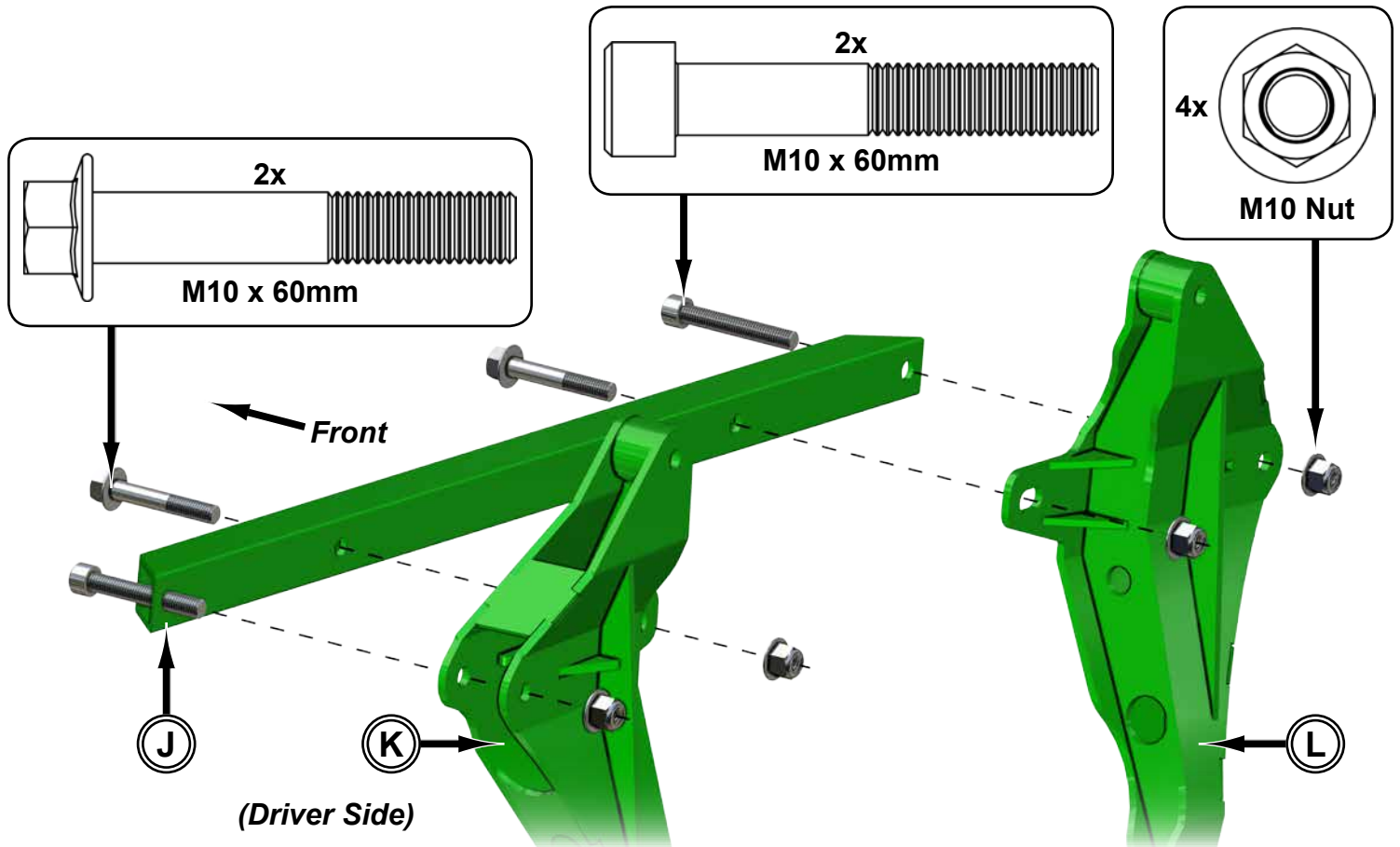

Front installation continued:

- Install new Axles.
- Secure lower section of Shocks to Front Upper Arms (E)(G) with stock hardware. **Do not install any Nuts until all final adjustments have been completed.**
- Reinstall Knuckles, Hubs, and Calipers. **Do not install any Nuts until all final adjustments have been completed.**
- Secure Tie Rod Ends to Knuckles.
- Route, connect, and secure new Brake Lines (P). Secure with provided Brake Line Clips and hardware shown.

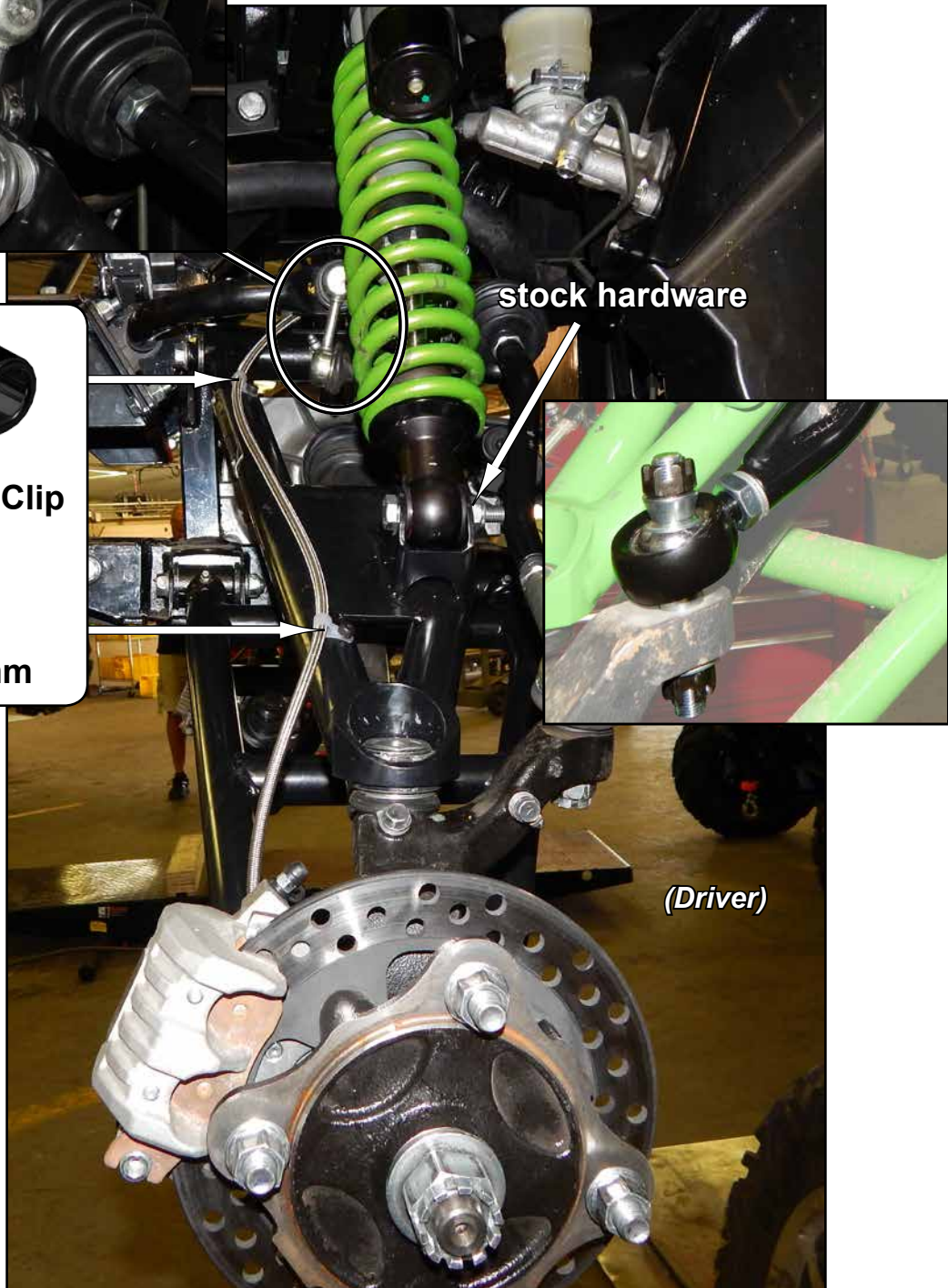
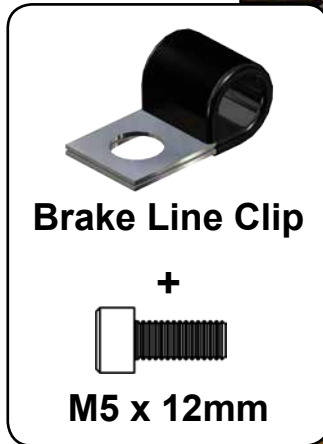

Remove REAR components shown: Keep all components and hardware removed from machine.

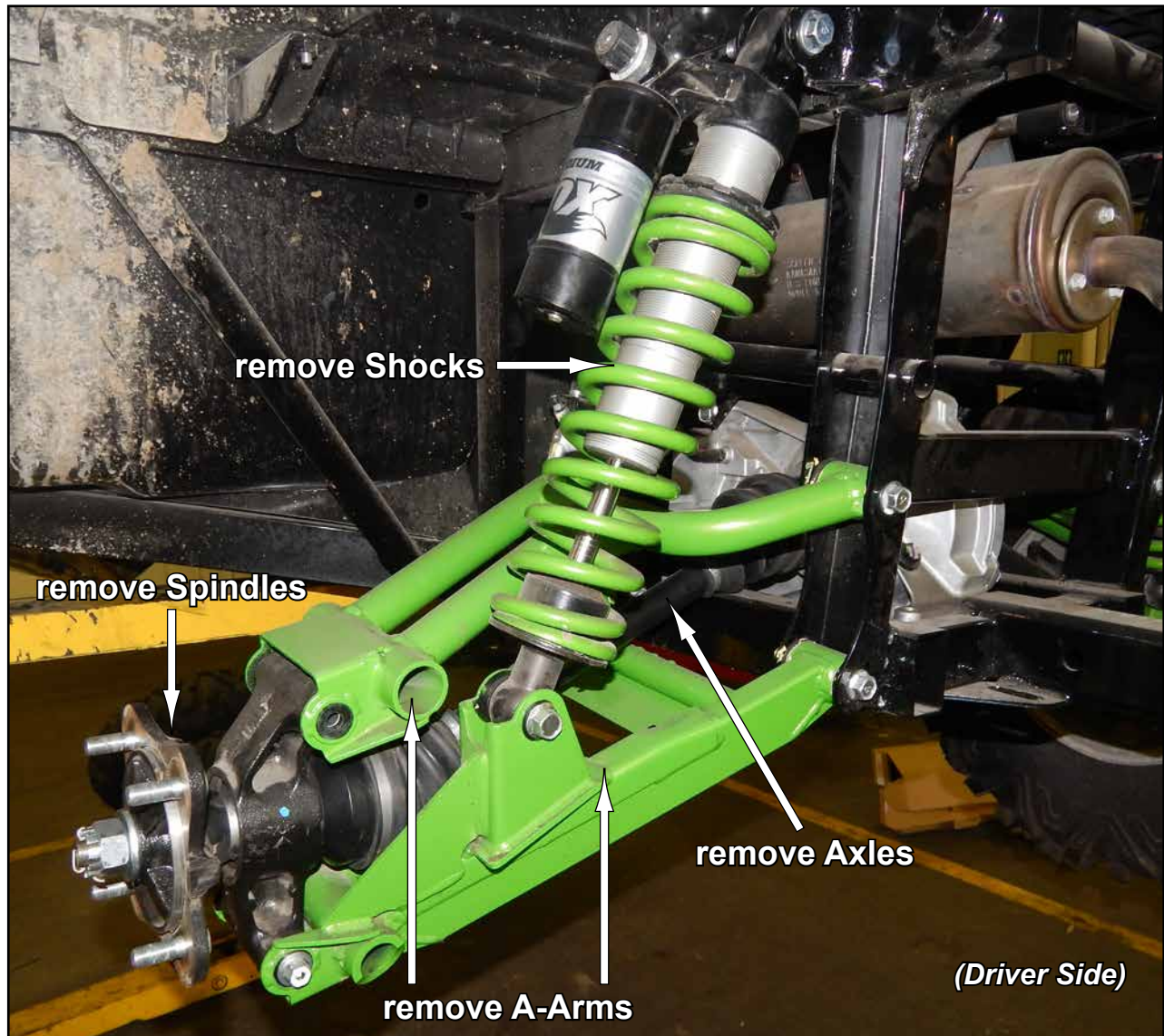

Rear Shocks Prep:



Rear A-Arms Prep:

- Transfer stock Bushings, Caps, and O-Rings into new A-Arms.
- If not installed, install provided Fittings into new A-Arms.

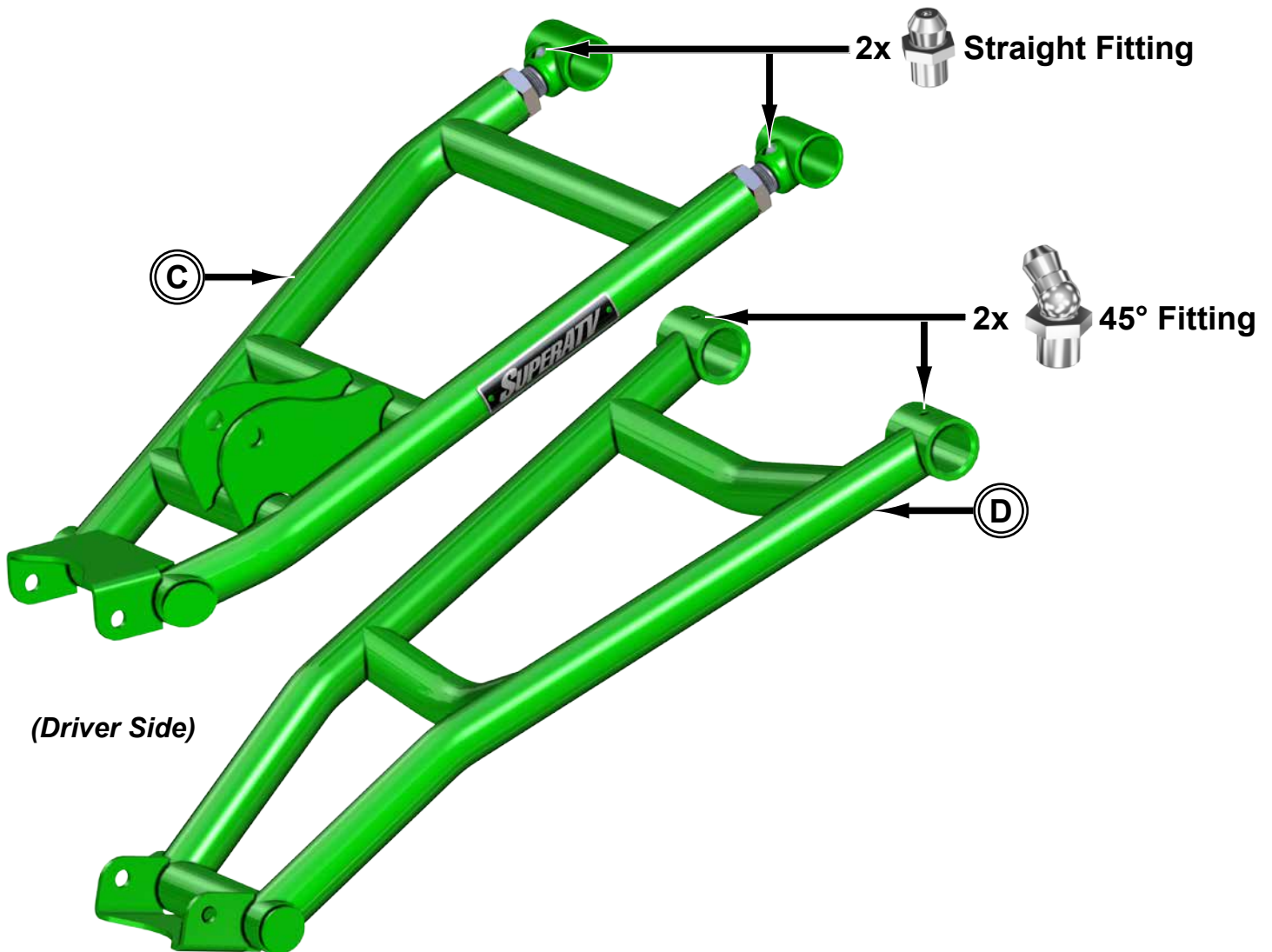

PIVOT BLOCK SETTINGS

- Place new A-Arms onto a flat surface and verify dimension shown.
- *Negative 1° camber setting is achieved when Pivot Blocks are set to this dimension.*
- See last page for additional camber information.

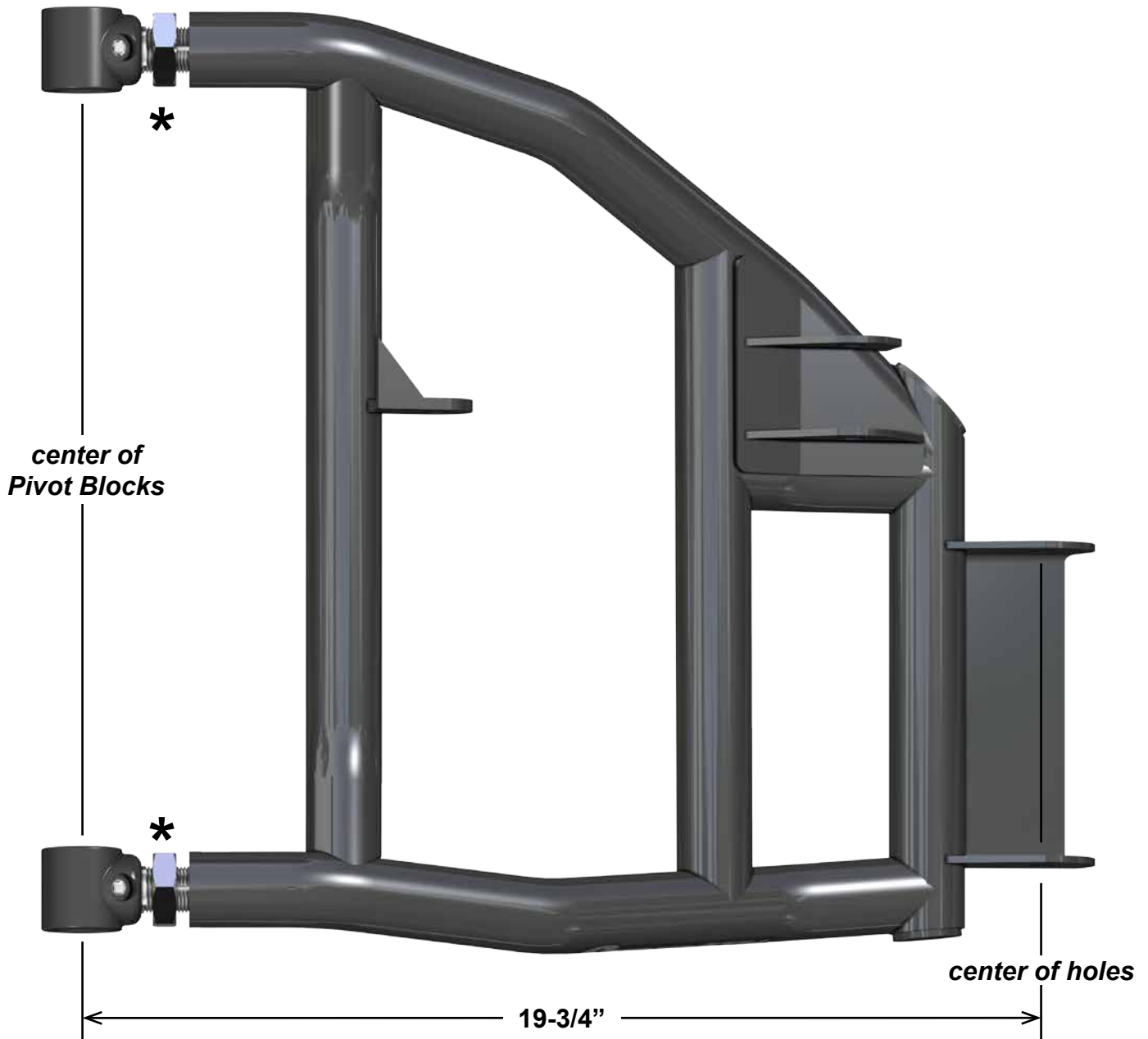

*** Leave Jam Nuts loose. Tighten after final adjustments have been made.**

Rear installation:

- Install new Rear Bracket (M) to stock Shock Mount with hardware shown.
- Install Rear Upper Arm (C) with stock hardware and hardware shown: *Bolt will go through, and secure, lower section of Rear Bracket (M).*
- Install Rear Lower Arm (D) with stock hardware. **Do not install any Nuts until all final adjustments have been completed.**
- Repeat steps for opposite side.

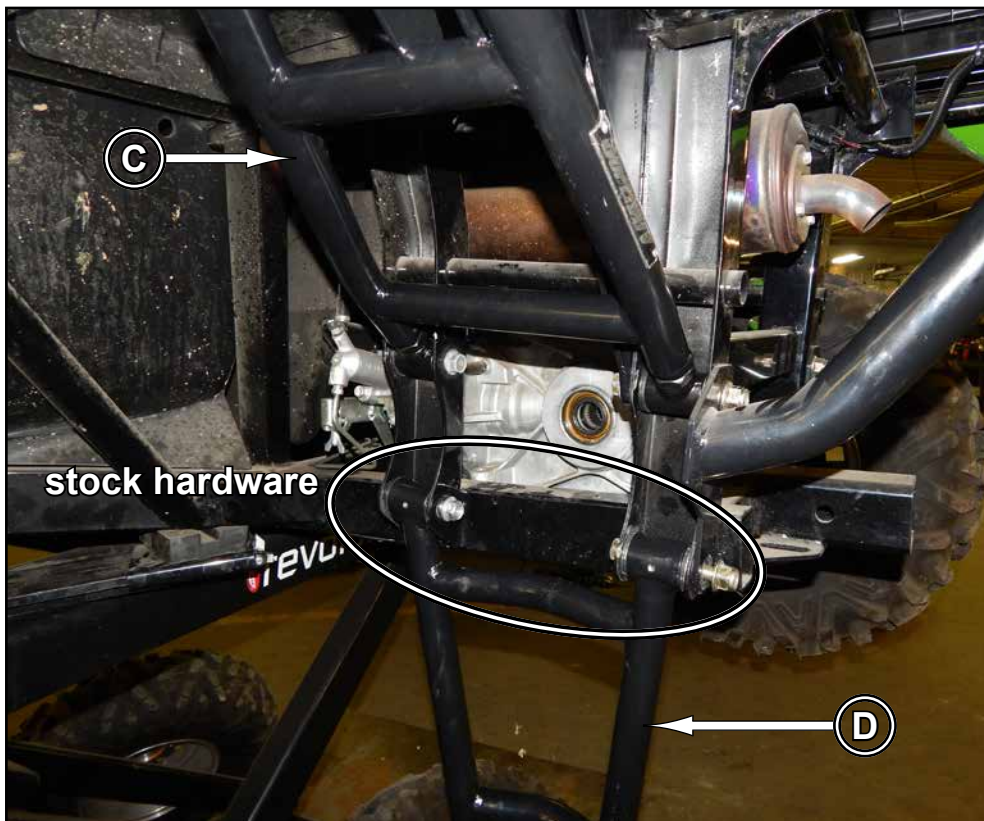
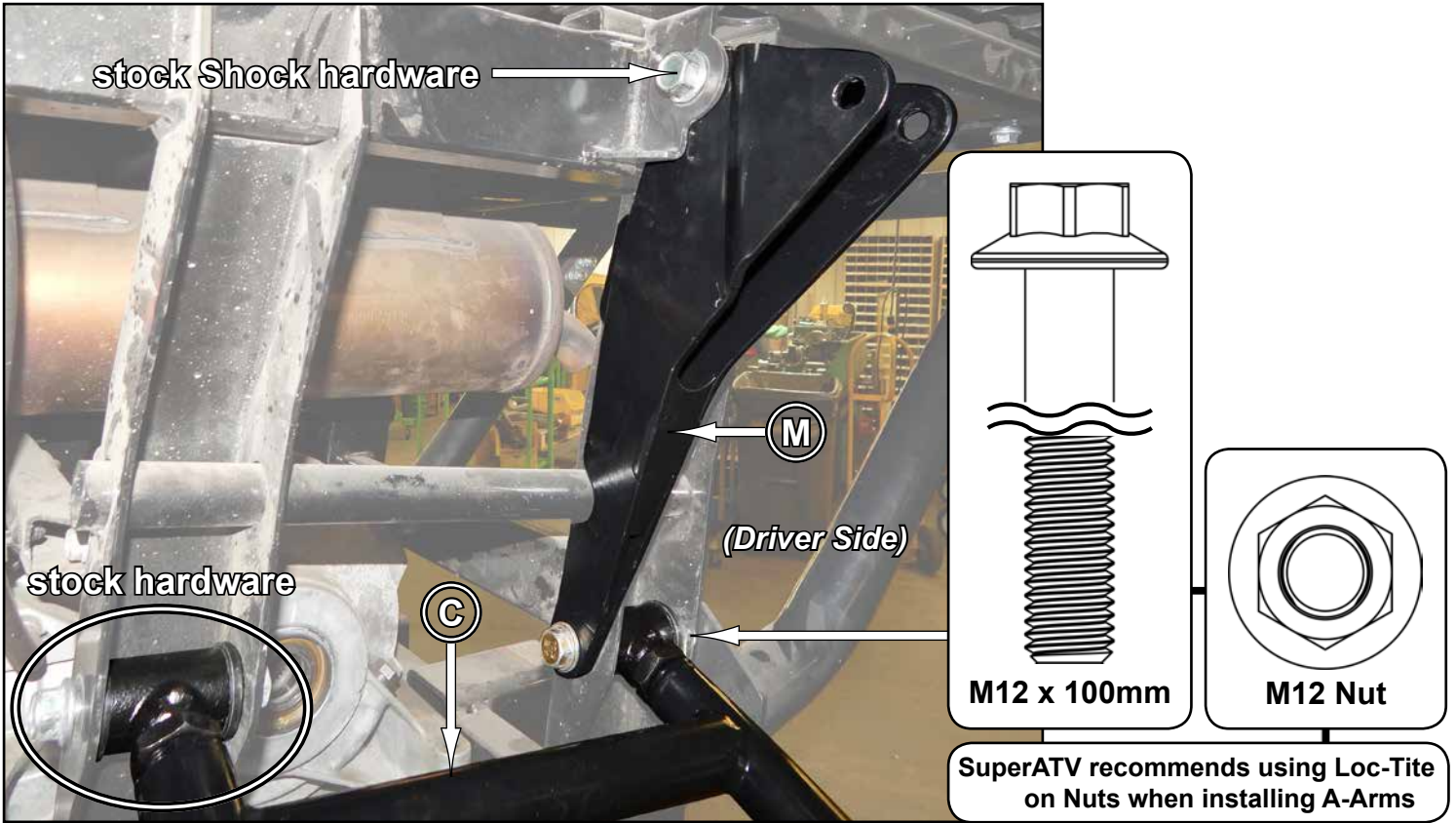

Rear installation continued:

- Install new Axles. *Stock Collars will install to outside of Spindles.*
- Reinstall Spindles with stock hardware. **Do not install any Nuts until all final adjustments have been completed.**
- Secure upper sections of Shocks to Rear Brackets with hardware shown.
- Secure lower sections of Shocks to Rear Upper Arms with stock hardware. **Do not install any Nuts until all final adjustments have been completed.**

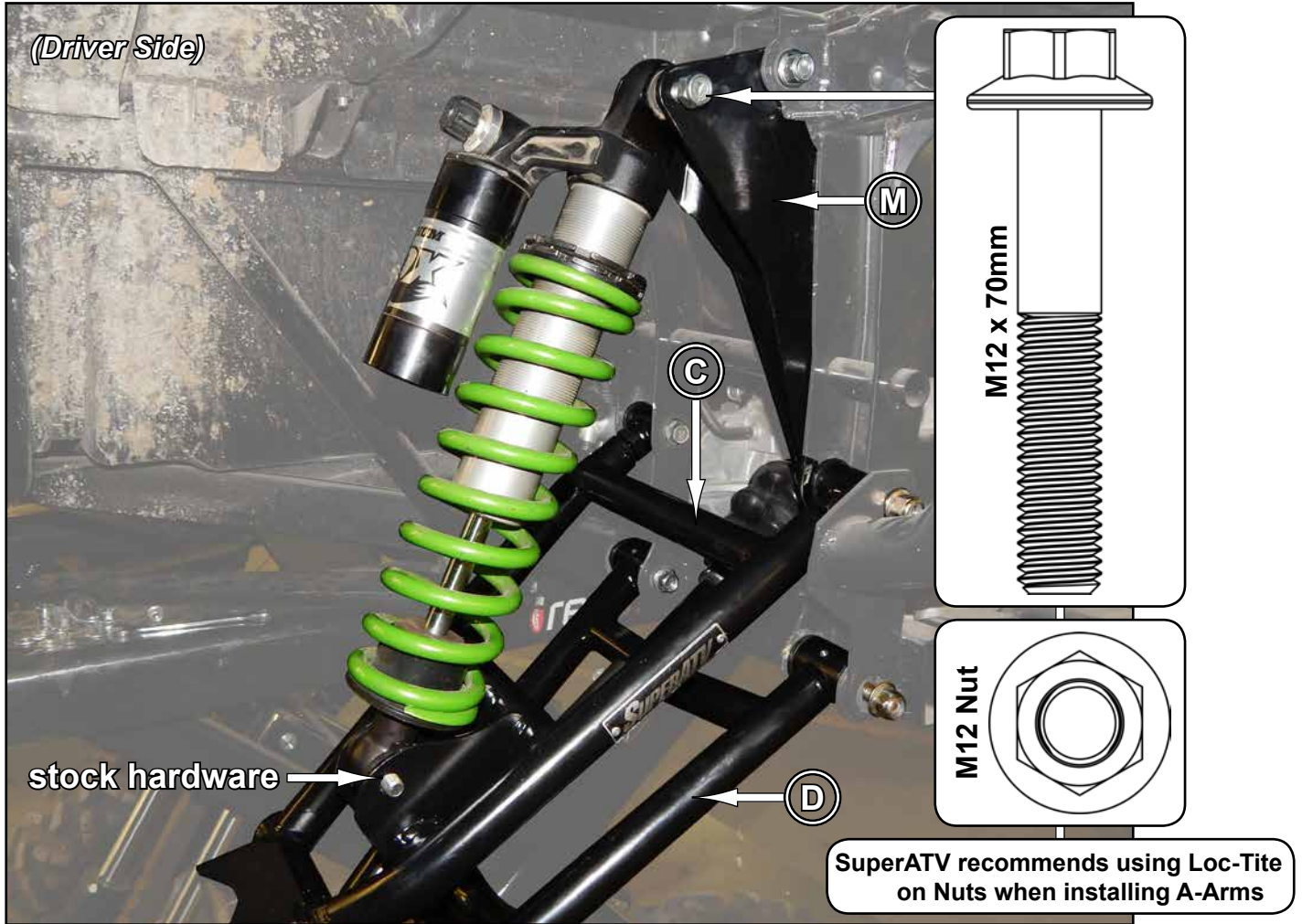

- Reinstall Tires and check Camber settings; see last page.
- Add Nuts to previously installed hardware and tighten completely.

CAMBER

- Tires must have equal air pressure before making adjustments.
- Adjustments to be made after all suspension components have been completely assembled.
- Tires must not be in contact with ground when making adjustments.
- Perform adjustments in small increments.

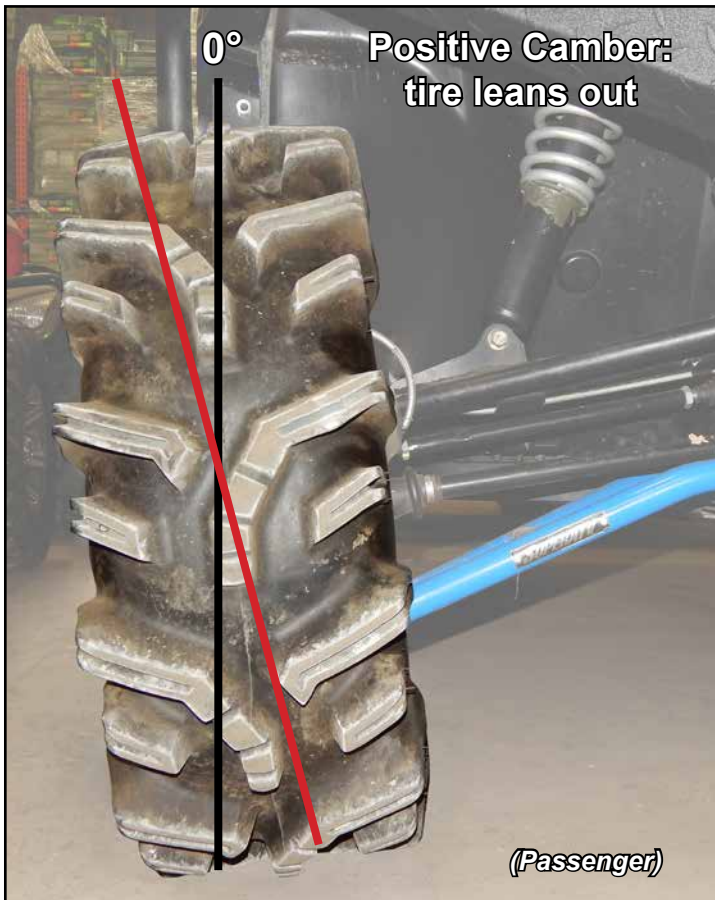

Adjusting Camber:

- Remove A-Arms from Frame and turn Pivot Blocks to adjust camber. Reinstall Arms.
- Lower machine and settle suspension components by rolling machine back and forth several feet at a time.
- Check settings and make small adjustments as needed.
- Each time an adjustment is made, machine must be rolled back and forth to settle suspension components.
- Once desired setting is achieved, tighten hardware completely. Loc-tite on Nuts is recommended.

A NEGATIVE CAMBER SETTING OF 1° to 2° IS RECOMMENDED.

LOWER:

Too much positive camber: adjust Pivot Blocks **OUT**.

Too much negative camber: adjust Pivot Blocks **IN**.

note: 2 full turns is 1°

UPPER A-ARMS:

Too much positive camber: adjust Pivot Blocks **IN**.

Too much negative camber: adjust Pivot Blocks **OUT**.

note: 2 full turns is 1°

