



INSTALLATION INSTRUCTIONS



2011-2016 FORD F-250/F-350 SUPERDUTY

TRACTION BARS - LONG BED ONLY

FT62007i

Fabtech Motorsports | 4331 Eucalyptus Ave. Chino, CA 91710

Tech Line: 909-597-7800 | Fax: 909-597-7185 | Web: www.fabtechmotorsports.com

**- PARTS LIST -
2011-2016 FORD F-250/F-350 TRACTION BARS (LONG BED ONLY)**

FTS62007		2011-16 F-250/350 TRACTION BARS
1	FT90094BK	TRACTION BAR 67" (DRIVER)
1	FT90095BK	TRACTION BAR 67" (PASSENGER)
2	FT90018	TRACTION BAR SHACKLE ZINC
1	FT30734	AXLE BRACKET (DRIVER)
1	FT30735	AXLE BRACKET (PASSENGER)
2	FT90027	UPPER REAR TRACTION BAR MOUNT
1	FT30632BK	FRAME BRACKET (DRIVER)
1	FT30633BK	FRAME BRACKET (PASSENGER)
4	FT749U	U-BOLT RD 5/8-18 X 20.00 X 3.50
1	FT30634	SPACER PLATE
1	FT30637	HARDWARE SUBASSEMBLY
1	FT30638	HARDWARE KIT

FT30638 - HARDWARE KIT		LOCATION
2	1/2-13 X 4" HEX BOLT G8	FRAME BRACKET
4	1/2-13 X 6" HEX BOLT G8	AXLE BRACKET
11	1/2 SAE WASHER	
5	1/2-13 C-LOCK NUT	
2	1/2 SPLIT LOCK WASHER	
2	3/8-16 X 3/4 HEX SELF TAP	FRAME BRACKET
6	3/4-10 X 3" HEX BOLT G8	TRACTION BAR AXLE
12	3/4" SAE WASHER	
6	3/4-10 C-LOCK NUT	
6	JAM NUT 3/4-16 RH	
1	THREAD LOCKING COMPOUND	

FT30637		HARDWARE SUBASSEMBLY
8	FT192	SLEEVE 1.250 X .750 X .570
1	FT58H	5/8" U-BOLT HARDWARE KIT
6	FTS98003	3/4" ROD END
4	FT1004	SWAY BAR LINK BUSHING HALF
1	FT30635	NUT TAB
2	FT66	SLEEVE .625 X .509 X 2.000
1	FTAS16	DRIVER WARNING DECAL
1	FTAS12	STICKER FT BLUE 10X4
1	FTREGCARD	REGISTRATION CARD
1	FT62007i	INSTRUCTIONS
8	FT20731	TRACTION BAR SPACER



- TOOL LIST -

Required Tools (Not Included)

Basic Hand Tools
Floor Jack
Jack Stands
Assorted Metric and S.A.E sockets, and Allen wrenches
Torque Wrench

- PRE-INSTALLATION NOTES -

For technical assistance call: **909-597-7800** or e-mail: **info@fabtechmotorsports.com**

READ THIS BEFORE YOU BEGIN INSTALLATION -

Check all parts to the parts list above before beginning installation. If any parts are missing contact Fabtech at 909-597-7800 and a replacement part will be sent to you immediately.

Read all instructions thoroughly from start to finish before beginning the installation. If these instructions are not properly followed severe frame, driveline and / or suspension damage may occur.

Check your local city and state laws prior to the installation of this system for legality. Do not install if not legal in your area.

Prior to the installation of this suspension system perform a front end alignment and record. Do not install this system if the vehicle alignment is not within factory specifications. Check for frame and suspension damage prior to installation.

The installation of this suspension system should be performed by two professional mechanics.

This suspension must be installed with Fabtech shock absorbers.

Use the provided thread locking compound on all hardware.

WARNING- Installation of this system will alter the center of gravity of the vehicle and may increase roll over as compared to stock.

Vehicles that receive oversized tires should check ball joints, uniballs, tie rods ends, pitman arm and idler arm every 2500-5000 miles for wear and replace as needed.

Verify differential fluid is at manufactures recommended level prior to kit installation. Installation of the kit will reposition the differential and the fill plug hole may be in a different position. (For example, if the manufacture recommends 3 quarts of fluid, make sure the diff has 3 quarts of fluid). Check your specific manual for correct amount of fluid.

FOOTNOTES -

- LONG BED MODELS ONLY
- CREW CAB MODELS ONLY

- INSTRUCTIONS -

FRONT SUSPENSION

1. Disconnect the negative terminal on the battery. Jack up the rear end of the truck and support the frame rails with jack stands. **NEVER WORK UNDER AN UNSUPPORTED VEHICLE!** Remove the rear tires.
2. Locate both Fabtech traction bars and install the supplied FTS98003 Heim joints into the single tube end. Locate FTS98003 Heim joints and install two into the end of the traction bar with the two-tube ends. You will need to thread them in so that 3/4" of thread (Including the Jam Nut) show. A minimum amount of 1" of thread should be threaded into the traction bars at all times. Thread engagement will vary due to truck heights. A starting point should be 70-1/4" from the front Heim to the top rear and 70-3/8" for the bottom.
3. **YOU SHOULD ONLY PERFORM THE FOLLOWING STEP FROM ONE SIDE OF THE VEHICLE AT A TIME.** Working from the driver side of the vehicle, locate the u-bolts and u-bolt plates and remove. **SEE FIGURES 1-2**

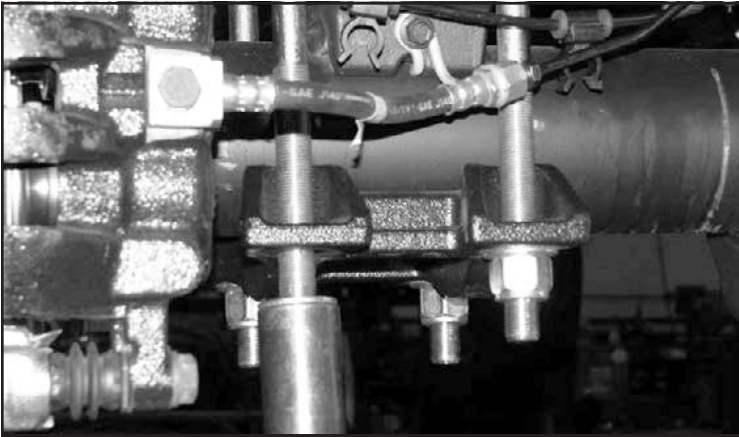

FIGURE 1 - STEP 3

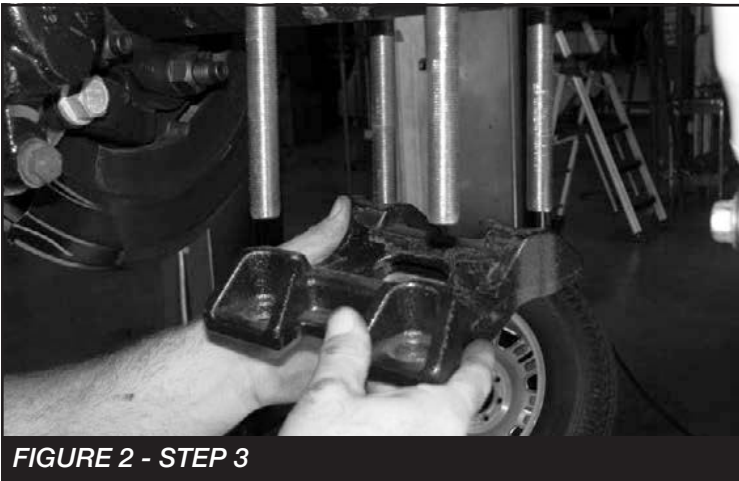

FIGURE 2 - STEP 3

4. Locate the Fabtech lower axle bracket FT30734, upper axle bracket FT90027, four FT192 sleeves and FT749U u-bolts. Slide the new u-bolts over the top of the spring in the factory configuration with factory lower plate. Install the sleeves and lower bracket on to the u-bolts under the axle. Leave u-bolt nuts loose at this time. **SEE FIGURES 3-4**

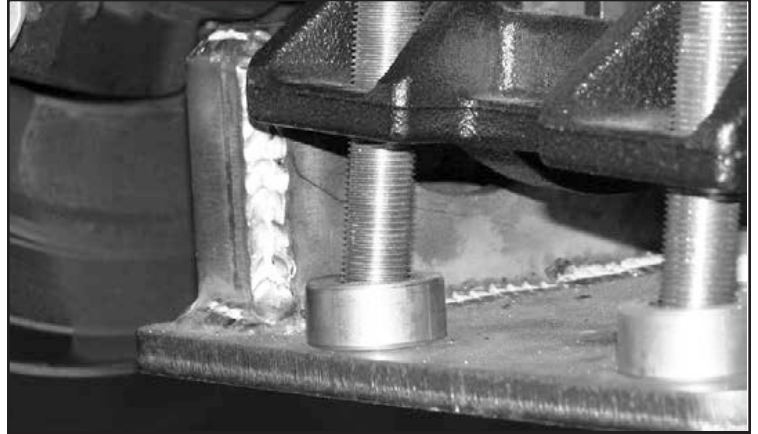

FIGURE 3 - STEP 4



FIGURE 4 - STEP 4

5. Using two 1/2-13 x 6" bolts, washers and nuts, install the FT90027 upper clamp bracket on the backside of the axle housing.. Torque the u-bolt nuts to 254 ft-lbs and upper 1/2" hardware to 90 ft-lbs. **SEE FIGURE 5**

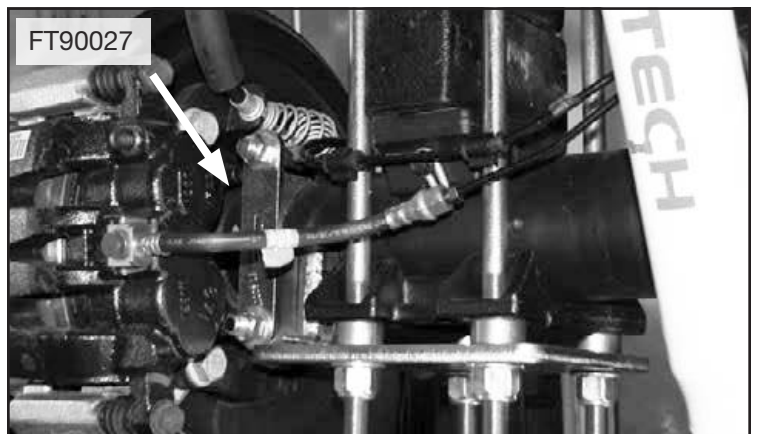

FIGURE 5 - STEP 5

6. On the driver side of the vehicle locate and remove the 2 bolts attaching the fuel tank cover. **SEE FIGURE 6**

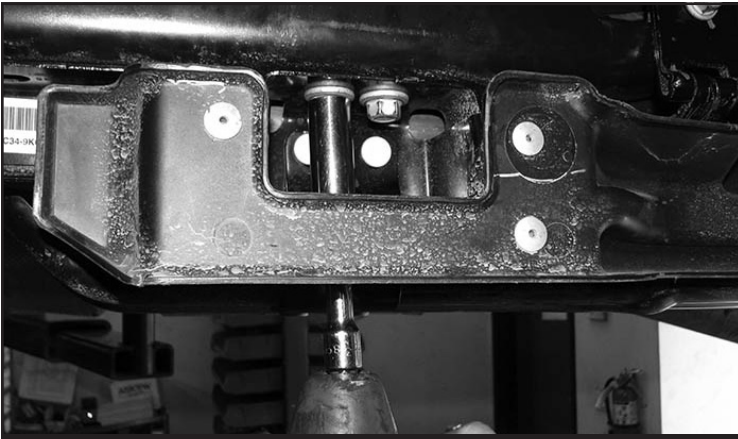

FIGURE 6 - STEP 6

7. Locate the fuel tank mounting strap. Remove the bolt and clip-on nut attaching it to the frame. **SEE FIGURE 7**. Loosen the same strap from the backside of the tank but do not remove. **SEE FIGURE 8**.

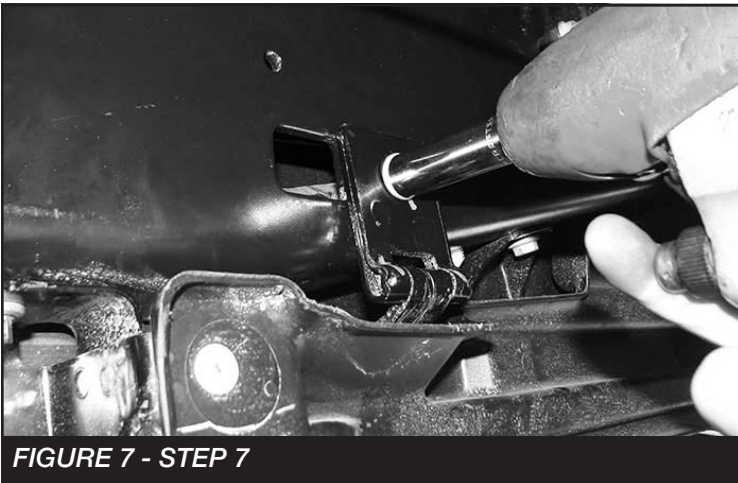

FIGURE 7 - STEP 7



FIGURE 8 - STEP 7

8. Using a step drill bit. Drill the fuel tank mounting strap to 1/2" **SEE FIGURE 9**, Next, mark and cut a radius on the plastic fuel tank cover. It will measure the width of the strap and 1" from the edge. **SEE FIGURE 10**.



FIGURE 9 - STEP 8

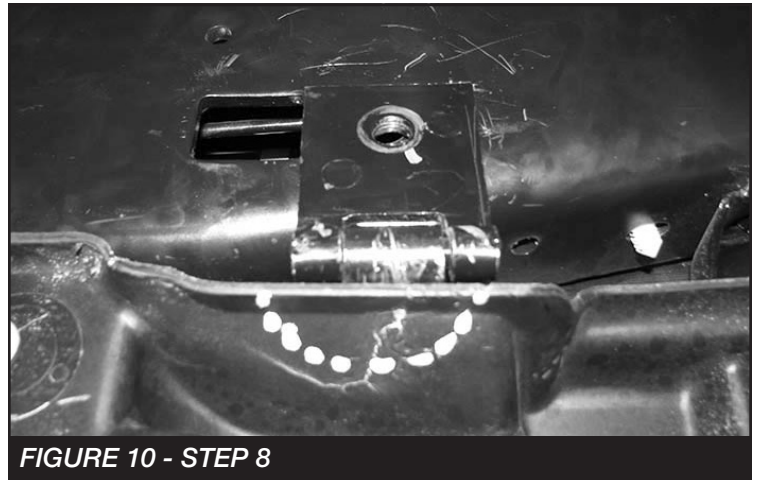

FIGURE 10 - STEP 8

9. Using 1 of the factory bolts install FT30632BK (Driver frame bracket) and mark the hole **SEE FIGURE 11**. Remove the bracket. Using a barrel sander or carbide bit open up the hole. **SEE FIGURE 12**.

- **NOTE: USE CAUTION NOT TO HIT THE FUEL LINES OR WIRING HARNESSES LOCATED INSIDE THE FRAME RAIL.**

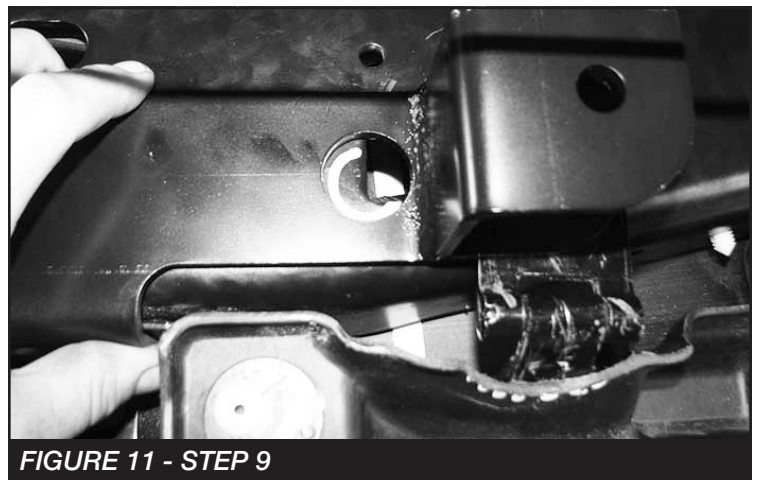

FIGURE 11 - STEP 9

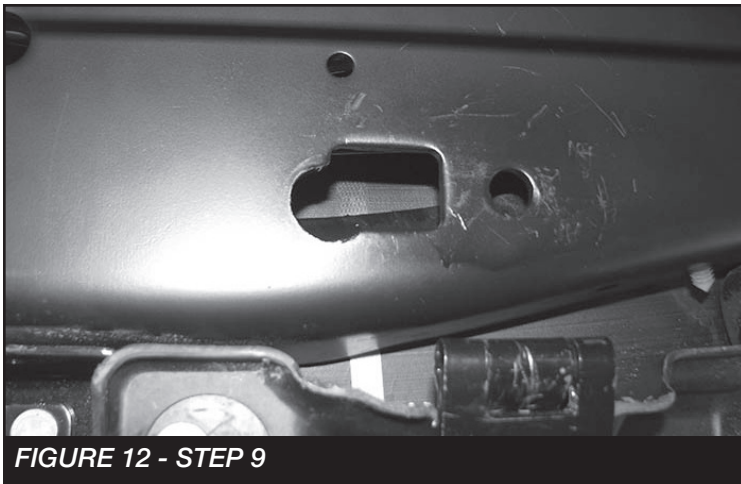

FIGURE 12 - STEP 9

10. Mount the FT30632BK (Driver frame bracket) using the factory bolts. Locate the Fabtech shackle bracket (FT90018) and install two FT1004 bushings and one FT66 sleeve into the end of the shackle with the barrel. Next, install the FT90018 (Shackle) to the Fabtech traction bar using the supplied 3/4"-10 X 3" hardware and FT20731 spacers at the axle end on each side of the heim joint. **NOTE: The shackle should be installed so the traction bar will offset away from the frame.** Install the assembly into the Fabtech frame bracket using the 1/2-13 X 4" bolt, lock washer flat washer and FT30635 (Nut Tab) by inserting the nut tab through the hole you previously opened up in step 9. **SEE FIGURES 13-14**

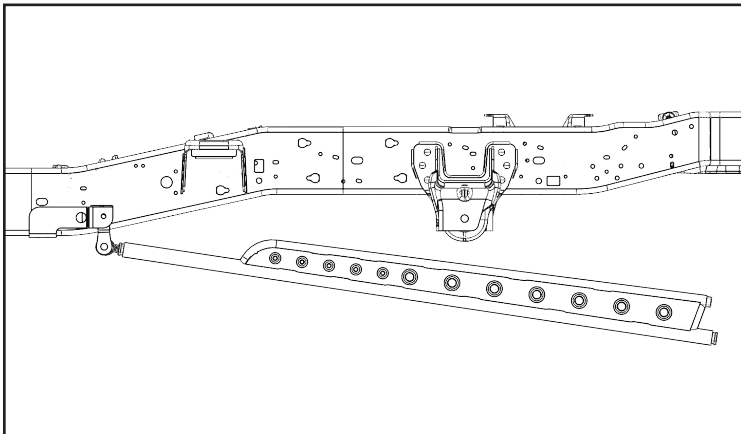

FIGURE 13 - STEP 10



FIGURE 14 - STEP 10

11. REPEAT STEPS 3-5 FOR PASSENGER SIDE. Next, Relocate the hole attached to the frame to the holes just above. **SEE FIGURE 14-15**

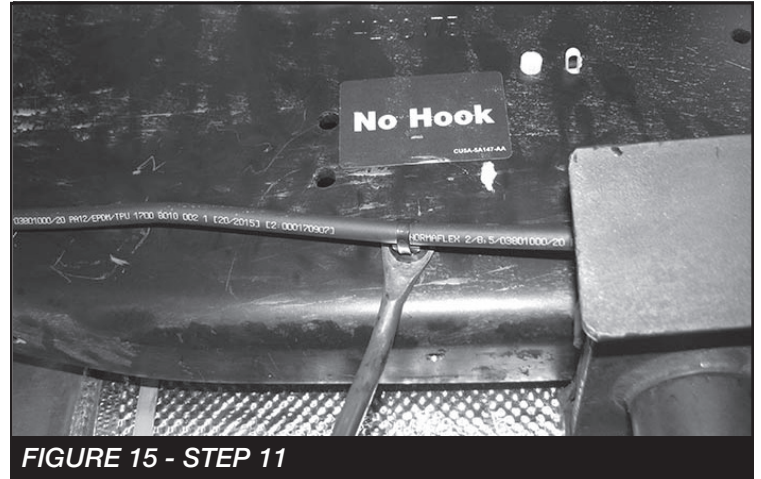

FIGURE 15 - STEP 11

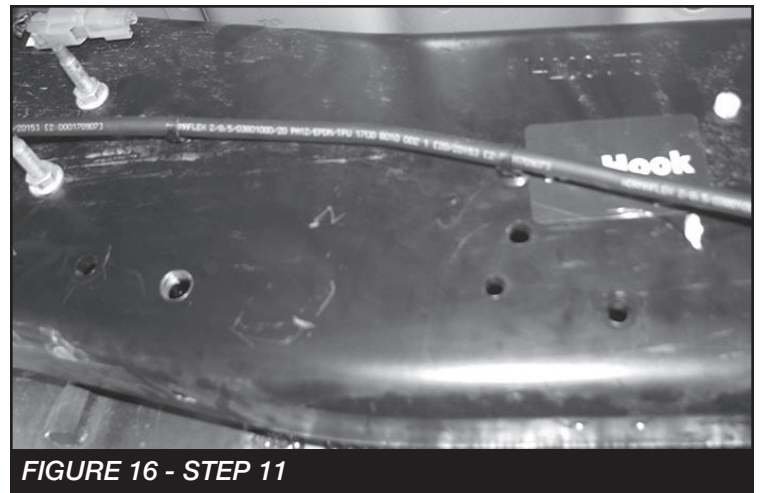

FIGURE 16 - STEP 11

12. Measuring from the body mount towards the rear of the vehicle. Measure 13-1/2" and mark. **SEE FIGURE 12**

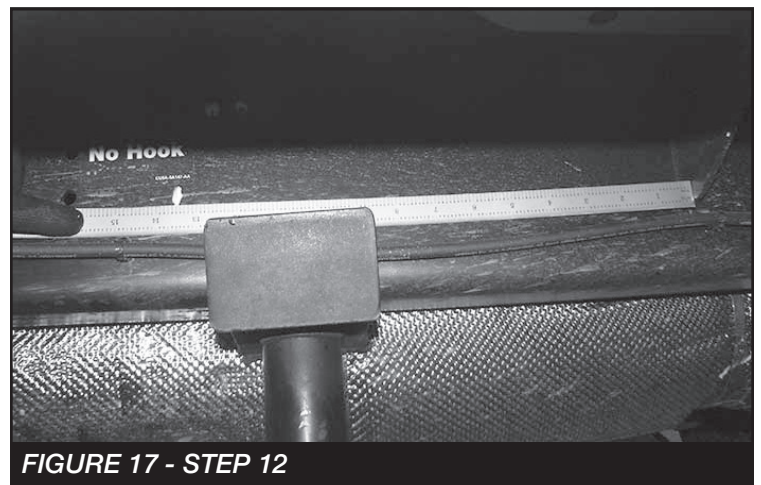

FIGURE 17 - STEP 12

13. Locate FT30633BK (Passenger frame bracket). Line up the front of the Fabtech frame bracket with the mark you made in step 12. Mark the 2 holes at the bottom **SEE FIGURE 18**. Drill out the bottom 2 holes using a 5/16" drill bit. Install one of the 3/8" self tapping bolts. Next, use a 1/2" center punch to mark the rear hole. **SEE FIGURE 19**.



FIGURE 18 - STEP 13



FIGURE 19 - STEP 13

14. Remove bracket and use a 1/2" drill bit and drill the rear hole on the frame. **NOTE: Use caution not to drill into any hoses or wiring on the backside of the frame.**
15. Install the bracket using the (2) supplied 3/8" self-tapping bolts. Torque to 37 ft-lbs. Locate the Fabtech shackle bracket (FT90018) and install two FT1004 bushings and one FT66 sleeve into the end of the shackle with the barrel. Next, install the FT90018 (Shackle) to the Fabtech traction bar using the supplied 3/4"-10 X 3" hardware. **NOTE: The shackle should be installed so the traction bar will offset away from the frame.** Install the assembly into the Fabtech frame bracket using the 1/2"-13 X 4" bolt, lock washer flat washers, nut and FT30634 (spacer plate). The spacer plate needs to be installed between the Fabtech bracket and the factory frame. Torque to 127 ft-lbs. **SEE FIGURE 20**

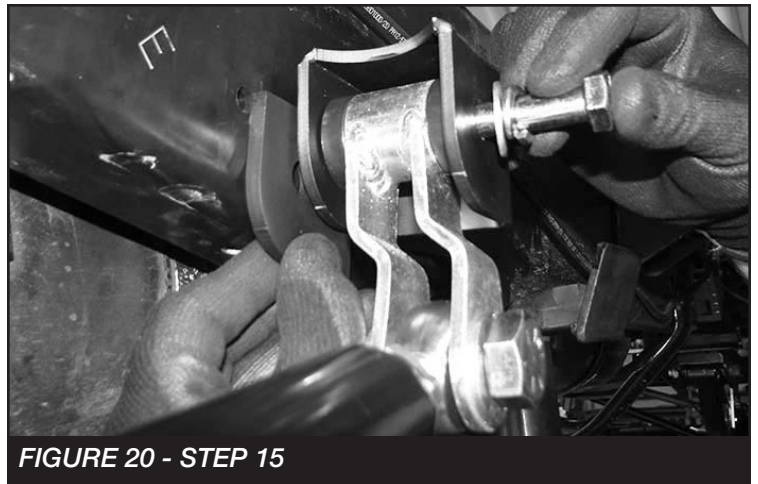

FIGURE 20 - STEP 15

16. Install tires and wheels and torque lug nuts to wheel manufacturer's specifications. Turn front tires left to right and check for appropriate tire clearance.
17. Recheck all bolts for proper torque.
18. Install Driver Warning Decal. Complete product registration card and mail to Fabtech in order to receive future safety and technical bulletins on this suspension.

Vehicles that will receive oversized tires should check ball joints, uniballs and all steering components every 2500-5000 miles for wear and replace as required.

RE-TORQUE ALL NUTS, BOLTS AND LUGS AFTER 50 MILES AND PERIODICALLY THEREAFTER.

For technical assistance call: **909-597-7800**

- Product Warranty and Warnings -

Fabtech provides a Limited Lifetime Warranty to the original retail purchaser who owns the vehicle, on which the product was originally installed, for defects in workmanship and materials.

The Limited Lifetime Warranty excludes the following Fabtech items; bushings, bump stops, ball joints, tie rod ends, limiting straps, cross shafts, heim joints and driveshafts. These parts are subject to wear and are not considered defective when worn. They are warranted for 60 days from the date of purchase for defects in workmanship.

Dirt Logic and Performance Coilover take apart shocks are considered a serviceable shock with a one year warranty on leakage only. Service seal kits are available separately for future maintenance. All other shocks are covered under our Limited Lifetime Warranty.

Fabtech does not warrant any product for finish, alterations, modifications and/or installation contrary to Fabtech's instructions. Alterations to the finish of the parts including but not limited to painting, powder coating, plating and/or welding will void all warranties. Some finish damage may occur to parts during shipping, which is considered normal and is not covered under warranty.

Fabtech products are not designed nor intended to be installed on vehicles used in race applications or for racing purposes or for similar activities. (A "RACE" is defined as any contest between two or more vehicles, or any contest of one or more vehicle against the clock, whether or not such contest is for a prize). This warranty does not include coverage for police or taxi vehicles, race vehicles, or vehicles used for government or commercial purposes. Also excluded from this warranty are sales outside of the United States of America.

Installation of most suspension products will raise the center of gravity of the vehicle and will cause the vehicle to handle differently than stock. It may increase the vehicle's susceptibility to a rollover, on road and off road, at all speeds. Extreme care should be taken to operate the vehicle safely at all times to prevent rollover or loss of control resulting in serious injury or death. Fabtech front end Desert Guards may impair the deployment or operation of vehicles equipped with supplemental restraining systems/air bag systems and should not be installed if the vehicle is equipped as so.

Fabtech makes every effort to ensure suspension product compatibility with all vehicles listed on the website, but due to unknown auto manufacturer's production changes and/or inconsistencies by the auto manufacturer, Fabtech cannot be responsible for 100% compatibility, including the fitment of tire and wheel sizes listed. The Tire and Wheel sizes listed in Fabtech's website are only a guideline for street driving with noted fender trimming. Fabtech is not responsible for damages to the vehicle's body or tires. Fabtech is not responsible for premature wear of factory components due to the installation of oversized tires and wheels.

Fabtech's obligation under this warranty is limited to the repair or replacement, at Fabtech option, of the defective product only. All costs of removal, installation or re-installation, freight charges, incidental or consequential damages are expressly excluded from this warranty. Fabtech is not responsible for damages and/or warranty of other vehicle parts related or non related to the installed Fabtech product. This warranty is expressly in lieu of all other warranties expressed or implied. This warranty shall not apply to any product that has been subject to accident, negligence, alteration, abuse or misuse as determined by Fabtech.

Fabtech suspension components must be installed as a complete system including shocks as shown on our website. All warranties will become void if Fabtech parts are combined and/or substituted with other aftermarket suspension products. Combination and/or substitution of other aftermarket suspension parts may cause premature wear and/or product failure resulting in an accident causing injury or death. Fabtech does not warrant products not manufactured by Fabtech.

Depending on the condition of the factory suspension components retained after the installation of a Fabtech suspension not all vehicles may have the same ride stance front to rear as described in the website. The blue color of suspension components shown in all Fabtech photographs are for display purposes only. Majority of all Fabtech components will be black specifically where noted with part numbers ending in BK.

Installation of Fabtech product may void the vehicles factory warranty; it is the consumer's responsibility to check with their local vehicle's dealer for warranty disposition before the installation of the product. Some state laws may prohibit modification of suspension to a vehicle in whole or in part. It is the responsibility of the installer and consumer to consult local laws prior to the installation of any Fabtech suspension product to comply with such written laws.

It is the responsibility of the distributor and/or the retailer to review all warranties and warnings of Fabtech products with the consumer prior to purchase.

Fabtech reserves the right to super cede, discontinue, change the design, finish, part number and/or application of parts when deemed necessary without written notice. Fabtech is not responsible for misprints or typographical errors within the website or price sheet. For the most recent Product Warranty and Warnings visit our website www.fabtechmotorsports.com