



**DOWNLOAD COLOR  
INSTALL MANUALS AT  
*dieselperformance.com***



# ***BD Ford 6L Flex Plate***

## **For 2003-07 Powerstroke Diesel Trucks**

**1041242****Ford 6L 5r110****2003-2007**

**PLEASE READ ALL INSTRUCTIONS BEFORE INSTALLATION.**

### ***Features***

- Over two times stronger than stock
- Fully billet machined, no welded weights.
- Not affected by hydrogen embrittlement caused by zinc plating, which can drastically reduce strength
- Correct ring gear that won't damage starter

### ***Installation***

BD Engine Brake Inc.  
Plant Address: 33541 MacLure Rd. Abbotsford, BC, Canada V2S 7W2  
U.S. Shipping Address: 88-446 Harrison St, Sumas, WA 98295 U.S. Mailing Address: P.O. Box 231, Sumas, WA 98295  
Phone: 604-853-6096 | Fax: 604-853-8749 | Internet: [www.bd-power.com](http://www.bd-power.com)

1. Remove transmission.
2. Remove OEM flexplate.

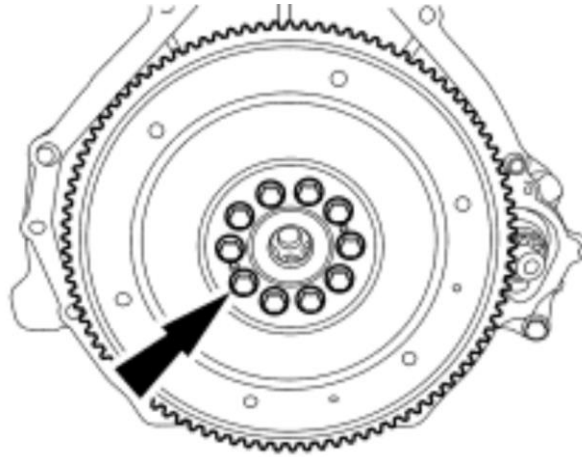

3. Install BD flexplate, align flexplate to locating dowel. Do not damage locating dowel.
4. Install BD (#1401243) hardened washer. Note that I can be installed two ways 180° apart from each other. Ensure to align and engage the locating dowel.

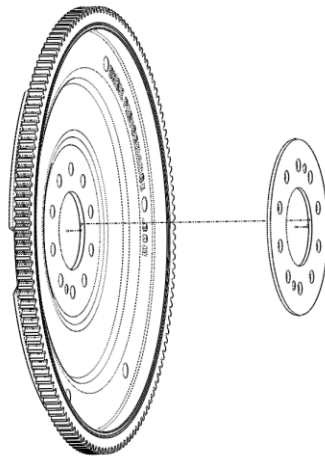

5. Re-install crankshaft bolts. Tighten in a two stage sequence.
  - a. Tighten first to 4 ftlbs.
  - b. Tighten to 69 ftlbs.



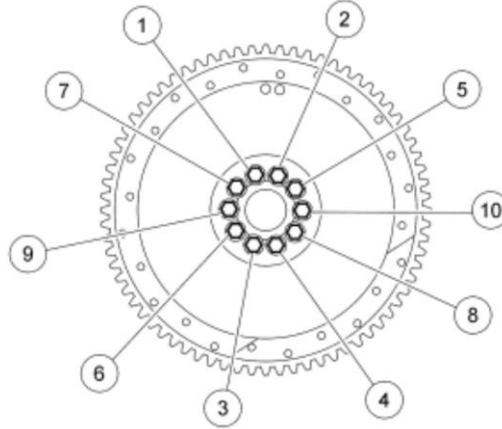

6. Lubricate the torque convertor hub with multi purpose grease.

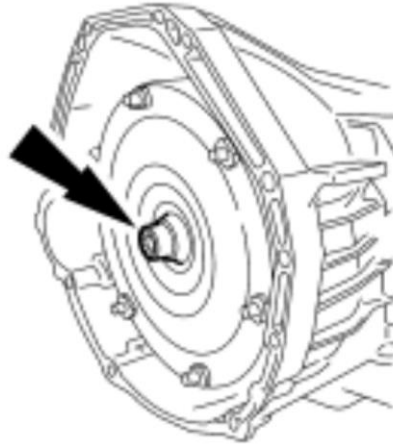

7. Re-install transmission and torque convertor. Torque flexplate to torque convertor nuts to 35ftlbs.

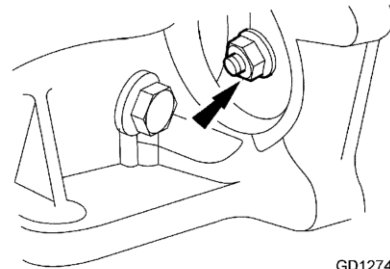

GD1274-A

Courtesy of FORD MOTOR CO.