

<THESE INSTRUCTIONS MUST BE GIVEN TO THE END USER>



B&W Trailer Hitches
 1216 Hawaii Rd / PO Box 186
 Humboldt, KS 66748
 P:620.473.3664
 F:620.473.3766

Call or Email us for
 Installation Support
 hitches@turnoverball.com
 www.turnoverball.com

Turnoverball™ Gooseneck Hitch Installation Instructions

Model 1012

**2011 - 2015 Chevrolet & GMC
 2500 & 3500 Heavy Duty Trucks**

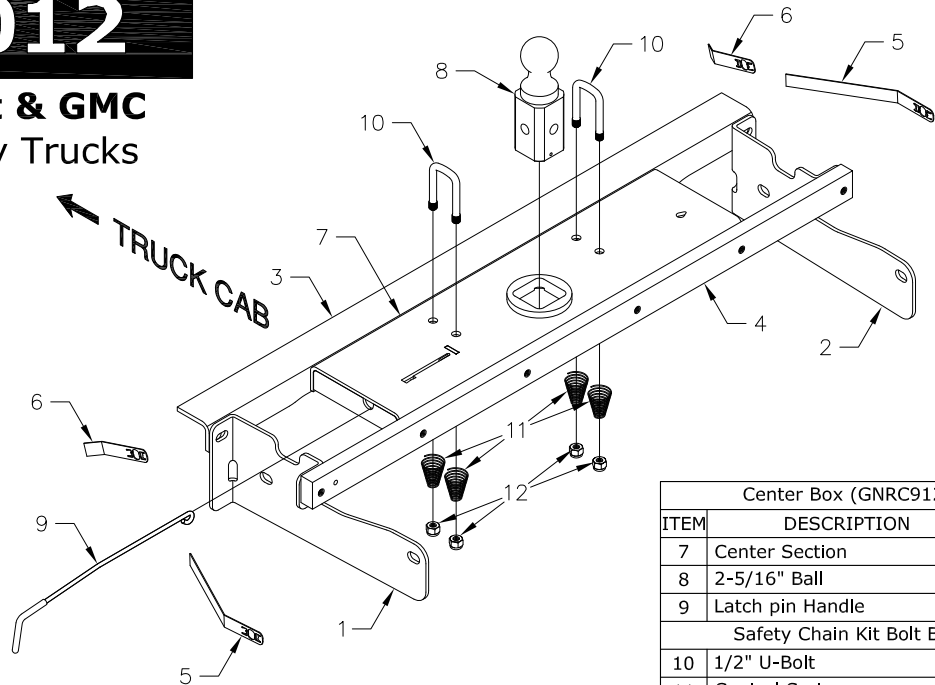

Mounting Kit Box (GNRM1012)		
ITEM	DESCRIPTION	QTY
1	Driver Side plate	1
2	Passenger Side plate	1
3	Front Cross member	1
4	Rear Cross member	1
5	Rear Bolt Guide	2
Mounting Kit Bolt Bag		
6	Front Bolt Guide	2
	O-Ring	1
	1/2" X 1-1/2" Cap Screw	8
	1/2" X 2" Cap Screw	4
	1/2" Flat Washer	8
	1/2" Lock Washer	12
	1/2" Finish Nut	6
	5/8" X 1-1/2" Cap Screw	4
	5/8" Flat Washer	4
	5/8" Lock Washer	4
	5/8" Finish Nut	4

Center Box (GNRC912)		
ITEM	DESCRIPTION	QTY
7	Center Section	1
8	2-5/16" Ball	1
9	Latch pin Handle	1
Safety Chain Kit Bolt Bag		
10	1/2" U-Bolt	2
11	Conical Springs	4
12	1/2" Lock Nut	4
	5/16" X 3/4" Carriage Bolt	1
	5/16" X 3/4" Cap Screw	1
	5/16" Flange Nut	1

⚠️ WARNING

Failure to comply with the safety information in these instructions could result in serious injury or death.

- ⚠️ Read all installation and operating instructions along with all labels before using this product.
- ⚠️ Without proper knowledge, towing can be a dangerous activity. Understand all the risks involved with towing before proceeding. For information on towing safety, see **"The Trailer Handbook: A Guide to Understanding Trailer and Towing Safety"** from the *National Association of Trailer Manufacturers*, www.NATM.com.
- ⚠️ The Turnoverball hitch comes equipped with a 2-5/16" ball. Trailers towed with the ball provided must have a 2-5/16" coupler. Towing with a larger coupler could cause loss of attachment between the trailer and the tow vehicle.
- ⚠️ This product was designed to fit vehicles in their original, "as manufactured" condition. Compatibility with vehicles having replacement parts, or other modifications is not guaranteed. Inspect vehicle for modifications before installation of this product.
- ⚠️ Do not modify this product in any manner. Doing so could alter its integrity and lead to a loss of attachment between the trailer and the tow vehicle.
- ⚠️ Do not exceed tow or tongue rating of coupler, tow or tongue rating of hitch, or tow or weight ratings of truck or trailer. See vehicle and trailer manufacturer information for ratings. Exceeding these ratings may cause damage to towing components or loss of attachment between the trailer and truck.
- ⚠️ Adding components such as a Turnoverball hitch to the chassis of any vehicle can be hazardous. There is potential for unexpected combustion of fuel, electric shock, burns, shifting or falling of unstable vehicle, damage to vehicle, injury from tool usage and many other hazards. This installation must be completed by someone who is aware of the hazards involved. This person must be knowledgeable of proper safety procedures for a vehicle modification of this nature, and for usage of the equipment required to perform the installation.

PREPARING TO INSTALL

Installation of the Turnoverball hitch requires several common tools and a few specialized tools. Below is a listing of equipment used during a typical installation.

- Impact wrench or ratchet with $\frac{3}{4}$ " & $\frac{15}{16}$ " sockets
- $\frac{3}{4}$ " and $\frac{15}{16}$ " box end wrench
- aviation snips for cutting sheet metal
- 4" hole saw
- flashlight
- drill with $\frac{1}{2}$ " bit
- eye protection
- torque wrench
- adjustable wrench
- lifting device
- tape measure
- ear protection

1. **Determine cab clearance.** The Turnoverball hitch is designed so that the ball can be inverted and stored below the surface of the truck bed while not in use. The ball location is determined by this design feature and the truck geometry. Measure the trailers to be towed with this hitch to be sure that the location of the 2-5/16" ball listed in step 7 will provide ample turning clearance between the nose of the trailers and the cab of the truck.

⚠ Cab clearance on short bed trucks is very limited when towing certain trailers. Failure to ensure that there will be adequate clearance, may result in significant property damage, or serious injury.

2. **Remove the spare tire (optional).** Following the vehicle manufacturer's instructions, remove the spare tire. This will provide easier access to the area where the hitch will be installed.

3. **Position the vehicle.** Installation of the hitch requires the installer to be under the truck bed in the area of the rear axle. Lifting the vehicle makes this area more accessible to the installer, and improves the installation process.

⚠ Lift vehicle using only equipment designed for lifting and positioning vehicles for service. Failure to do so may result in property damage, serious injury, or death.

4. **Prepare a lifting device (optional).** The purpose of the device is to safely hold the hitch in position during part of the installation. See figure A1 for an example. A simple mechanical lifting device is available for purchase from B&W.

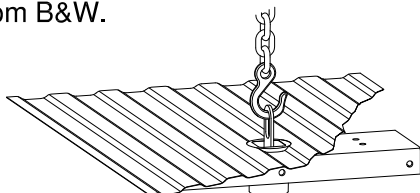

FIGURE A1

5. **Modify heat shield.** Cut out the section of the heat shield directly over the exhaust between the two bed cross members that are above the rear axle, see figure A2.

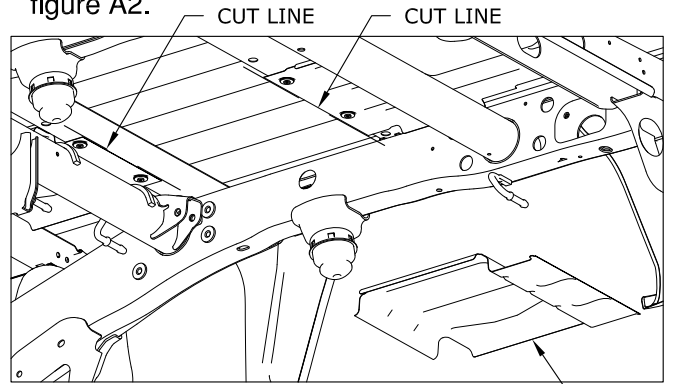

FIGURE A2: View Under Bed Looking at Heat Shield Removal Area

6. **Remove or modify fender liners as needed.** Some vehicles are equipped with various designs of plastic liners inside the rear wheel wells. If the liners prevent access to the opening between the bed and the frame, just over the axle, they may need to be removed or cut to install hitch cross members and handle.

7. **Mark the 4" hole location.** Using a tape measure hooked over the rear edge of the bed (at tailgate end), measure the location for the hole as shown in figure A3. Next, locate the center of the bed by measuring the distance between the wheel wells and dividing by two. The center of the hole will be at the intersection of the center of the bed and the first distance measured.

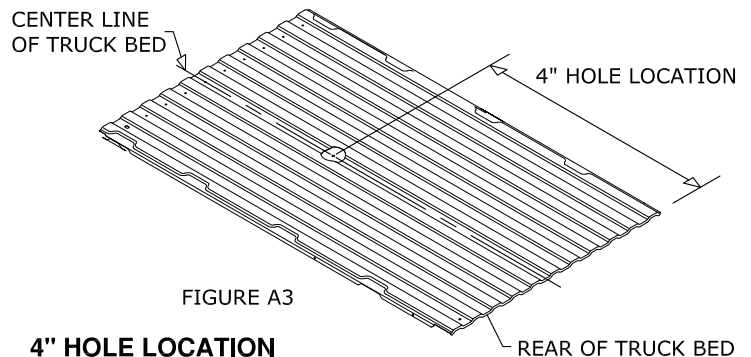

FIGURE A3

4" HOLE LOCATION

8' LONG BED - $49\frac{1}{2}$ "

SHORT BED (BED LESS THAN 8' LONG) - $44\frac{3}{4}$ "

IMPORTANT: The hitch is designed to install only at the described location. Failure to place the 4" hole precisely may result in added difficulty during installation or property damage.

8. **Cut the 4" diameter hole.** Cut the hole in the marked location using a 4" hole saw or by marking out the 4" hole and using a saber saw equipped with a metal cutting blade. Remove any burrs created while cutting hole.

IMPORTANT: If the bed is equipped with a plastic bed liner, the hole may be cut through both the liner and the bed. However, the center of truck bed may be more difficult to locate, and the mark may be harder to hit if the liner slides or moves. Failure to cut the hole in the correct location may adversely affect the install and may result in property damage.

1. **Modify bed flange.** Cut a notch in the bed flange just above the frame in the passenger side rear wheel well, as shown in figure A4. This notch is required for installing the hitch cross members.

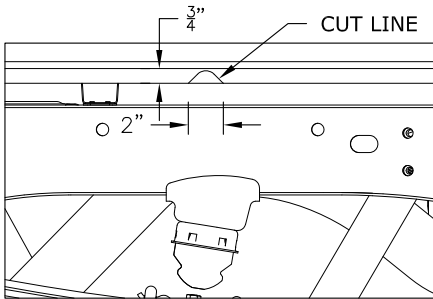

FIGURE A4: V-Shaped notch

INSTALL CROSS MEMBERS AND CENTER SECTION

⚠ Most trucks have fuel lines, brake lines, electrical wires or other vehicle systems located along the frame rails or in the general area where B&W Turnoverball hitches install. Carefully examine the locations of these systems before installation. Make certain that these are not damaged while positioning hitch components, drilling holes, or tightening fasteners. Damage to these systems may result in property damage, serious injury, or death.

⚠ Turnoverball hitch components are heavy and may be cumbersome to handle. Failure to use proper lifting techniques and caution when handling these items could result in serious injury.

1. **Place front cross member ($\frac{5}{16}$ thick angle).** Using the notch cut in the bed flange inside the passenger side rear wheel well, slide the cross member across the frame until it spans both frame rails. The flange of the cross member with the holes must be toward the rear of the truck, see figure B1. Using the rubber o-ring provided, secure a $\frac{1}{2}$ " x $1\frac{1}{2}$ " long bolt into the second hole in the cross member from the driver's side, as shown in figure B2. Slide the cross member toward the cab so that it is approximately 6" in front of the 4" hole in the truck bed. Rotate the cross member so that the leg of the angle with the holes is vertical, see figure B3.

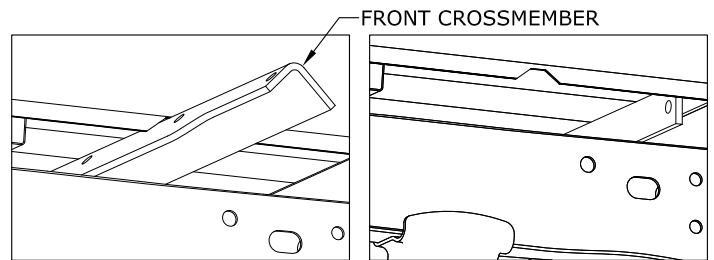

FIGURE B1: View above frame in passenger side wheel well.

FIGURE B3: View above frame in passenger side wheel well.

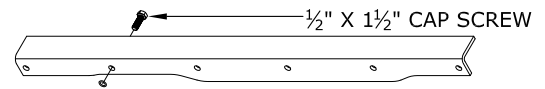

FIGURE B2: Front Cross Member

IMPORTANT: The o-ring must be tight against the cross member so that it does not prevent the nut from being tightened fully when the cross member is secured to the center.

2. **Stage center section.** Raise the center section into place as shown in figure B6, staging it for installation. When staged correctly, the receiver socket will be "offset" toward the rear of the truck. It may be helpful to pull down on the exhaust while positioning to allow extra room for maneuvering it into position.

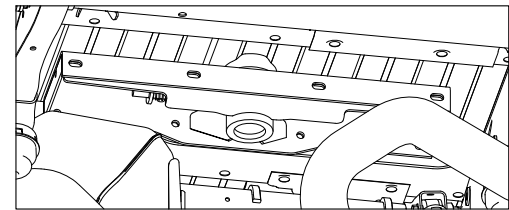

FIGURE B6: View of truck bed looking towards front of truck.

3. **Place the rear cross member (1" X 2" bar).** Slide the cross member between the bed and the frame just rearward of the center section until it spans both frame rails, see figure B7. The holes in the crossmember are closer to one edge than the other. Rotate the cross member $\frac{1}{4}$ turn so that the holes are closest to the bottom of the cross member. The narrow space between the bed and the frame will make it difficult to rotate the cross member. Rotation of the cross member can be made easier by using an adjustable wrench for leverage, see figure B8.

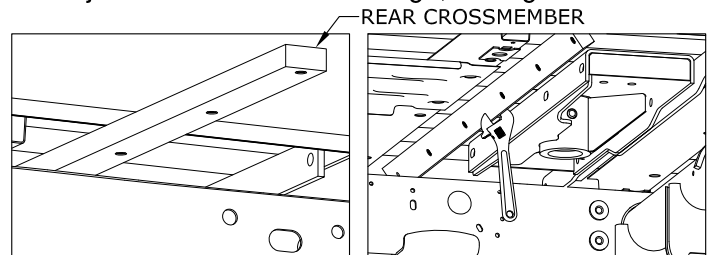

FIGURE B7: Rear Cross Member

FIGURE B8: Rear Cross Member

4. **Lift center:** Lift center section toward bed of truck. Guide the raised portion of the center through the 4" hole in the truck bed and keep the center tight against the floor of the bed.

5. **Attach the front cross member to the center.** Slide the front cross member back against the center section so that the bolt installed previously in the front cross member goes into the center section hole directly across from it. Line up the rest of the holes and attach the two members with $\frac{1}{2}$ X $1\frac{1}{2}$ " long bolts, lock washers, and nuts as shown in figure B10. Hand tighten nuts.

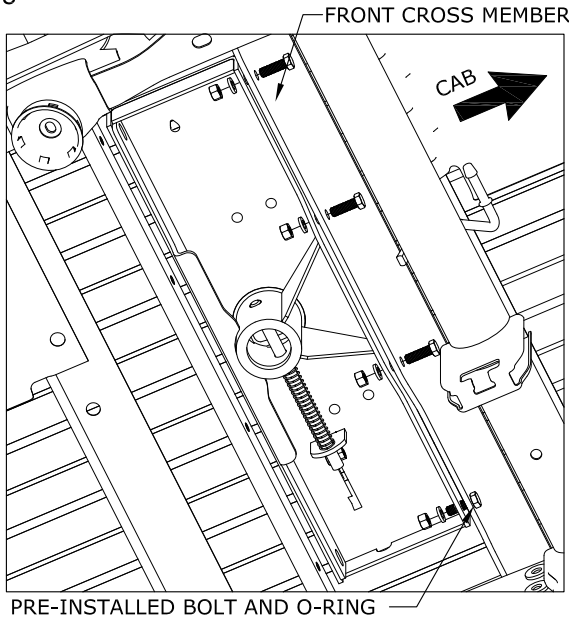

FIGURE B10: View under the center section looking from in front of the axle on the passenger side.

6. **Attach the rear cross member to the center.** Slide the rear cross member up against the center section. Line up the slots in the center with the threaded holes in the cross member. Attach the two members using $\frac{1}{2}$ x 2" long bolts, flat washers, and lock washers as shown in figure B11. Hand tighten bolts.

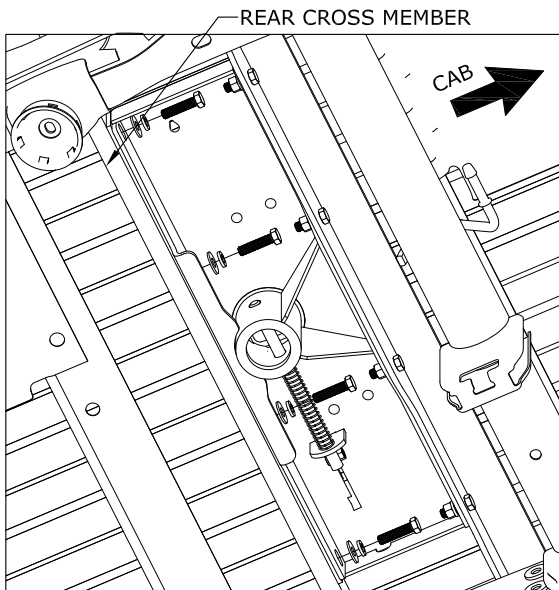

FIGURE B11: View under the center section looking from in front of the axle on the passenger side.

INSTALL SIDE PLATES

1. **Assemble bolt guides.** Assemble the bolt guides by threading a $\frac{5}{8}$ " bolt onto each guide as shown in figure C1 and C2. Tighten the bolt onto the guide so that the shoulder of the bolt head is flush with the surface of the bolt guide. This is designed to be a tight fit. A wrench may be needed to thread the bolts onto the bolt guides. The notches of the bolt guide must engage the corners of the bolt head so that the bolt is prevented from "backing off" of the guide. The notches of the bolt guide may have to be pried up if they were smashed down when the bolt was tightened down.

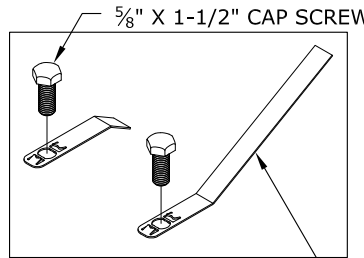

FIGURE C1: Bolt Guides

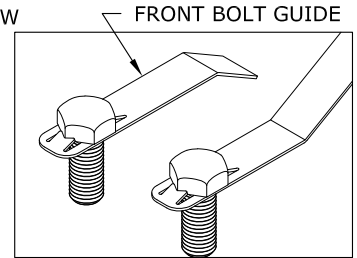

FIGURE C2: Bolt Guides
REAR BOLT GUIDE

2. **Install the bolt guides.** Insert the front bolt guides (shorter ones) into the frame and guide the threaded end of the bolts out the holes as shown in figures C3 to C5. Insert the rear bolt guides through the large holes on the inside of the frame rails and guide the threaded end of the bolts out of the holes in the frame as shown in figures C6 TO C8.

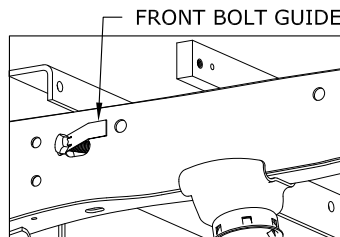

FIGURE C3: View from outside of Driver Side Frame, Bolt installation Step. 1

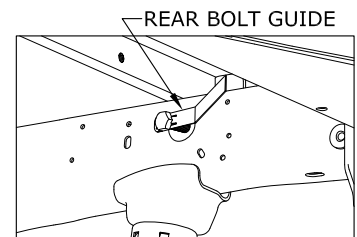

FIGURE C6: View from inside of Driver Side Frame, Bolt installation Step. 1

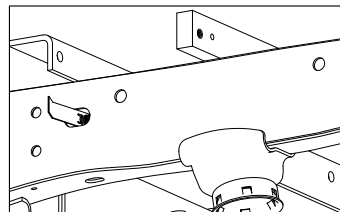

FIGURE C4: View from outside of Driver Side Frame, Bolt installation Step. 2

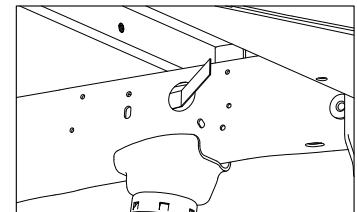

FIGURE C7: View from inside of Driver Side Frame, Bolt installation Step. 2

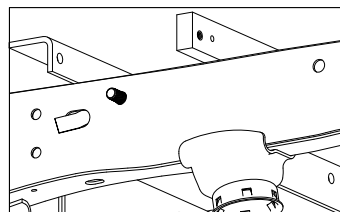

FIGURE C5: View from outside of Driver Side Frame, Bolt installation Step. 3

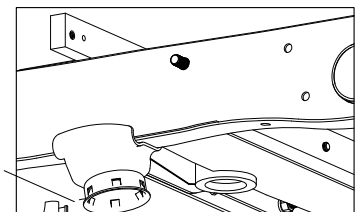

FIGURE C8: View from outside of Driver Side Frame, Bolt installation Step. 3

3. **Install the side plates.** Place each side plate over the $\frac{5}{8}$ " bolts held in place by the bolt guides, see figure C9. Attach the side plates to the frame with a flat washer, lock washer, and nut, see figure C10. Attach the side plates to the front and rear cross members with $\frac{1}{2}$ " hardware as shown in figure C11. Do not tighten the $\frac{5}{8}$ " or $\frac{1}{2}$ " hardware at this time.

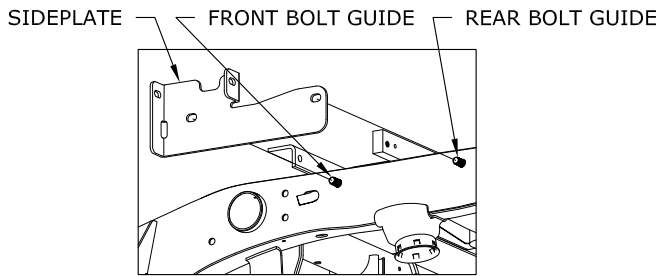

FIGURE C9: View from outside of Driver Side Frame

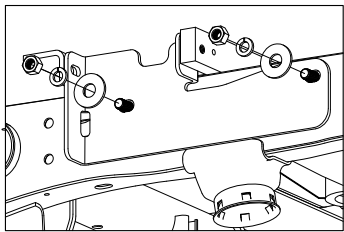

FIGURE C10: View from outside of Driver Side Frame

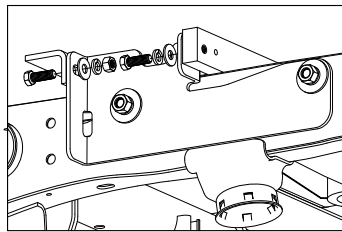

FIGURE C11: View from outside of Driver Side Frame

SECURE HITCH

1. **Tighten center section bolts.** With the top surface of the center section firmly against the truck bed, tighten the bolts securing the two cross members to the center section.
2. **Square the hitch.** With a tape measure, check the distance between the Turnoverball hitch and the nearest bed crossmember. The distance between the hitch and the crossmember should be consistent on the passenger side and the driver side of the hitch, see figure D1. Adjust hitch until the hitch and the bed crossmember are the same from side to side.

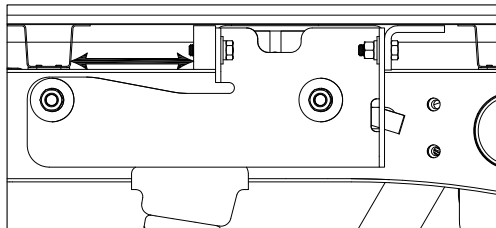

FIGURE D1: Passenger side of truck frame inside the wheel well.

IMPORTANT: The hitch must be square in the truck. If the center section is not parallel with the axle, certain accessories to the Turnoverball hitch will not be square with the truck.

3. **Tighten side plate bolts.** Tighten the $\frac{5}{8}$ " bolts, securing the side plates to the frame. Then tighten the $\frac{1}{2}$ " bolts that attach the side plates to the cross members.

4. **Torque all fasteners.** Torque the $\frac{1}{2}$ " bolts to 110 ft. lbs. and the $\frac{5}{8}$ " bolts to 150 ft. lbs.

⚠ Failure to follow the bolt tightening sequence as listed above may result in the hitch components being misaligned, which could affect the performance of the hitch, result in property damage, or serious injury.

5. **Disengage lifting device.** If a lifting device was used to hold the center section in place during the installation, remove it at this time.

INSTALL LATCH PIN RELEASE HANDLE.

IMPORTANT: The latch pin will not function properly if handle is not installed correctly.

1. Install the latch pin release handle by inserting it through the slot in the end of the center section on the driver side of the truck. Align the handle eyelet with the square hole in the latch pin so the handle is in line with the latch as shown in figure F1.
2. Secure the handle to the pin with the $\frac{5}{16}$ " X $\frac{3}{4}$ " carriage bolt and $\frac{5}{16}$ " locking flange, see figure F2. Note: The included $\frac{5}{16}$ " cap screw can replace the carriage bolt if wrench access on the "cab side" of the handle is limited. Tighten the nut until it is secure. Do not over-tighten and deform the handle eyelet.

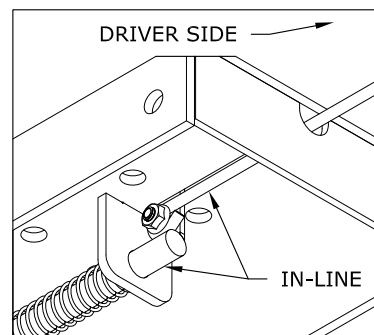

FIGURE F1: Center Section

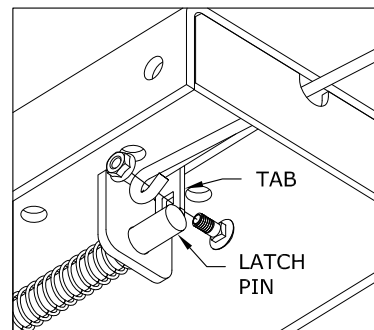

FIGURE F2: Handle Installation

INSTALL SAFETY CHAIN U-BOLTS

This Turnoverball hitch is equipped with holes in the center section for mounting safety chain u-bolts. The hitch is designed so that the u-bolts will be in a low rib of the truck bed in order to reduce the amount of obstruction in the bed. The center section of the hitch may have more than one set of holes. One set of holes should match up with a low rib of the truck bed. Carefully examine the safety chain holes in the center section to determine which holes are under a low rib, see figure G1.

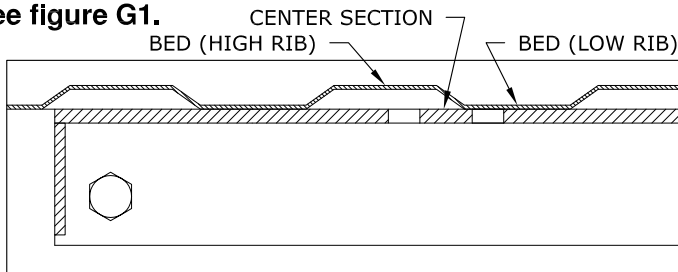

FIGURE G1: Cut away view of bed and center section

- 1. Drill the holes.** From under the bed use a drill and a $\frac{1}{2}$ " drill bit to drill through the bed using the four holes that match up with a low rib in the truck as a guide. Remove any burrs created during the drilling process, see figure G2.

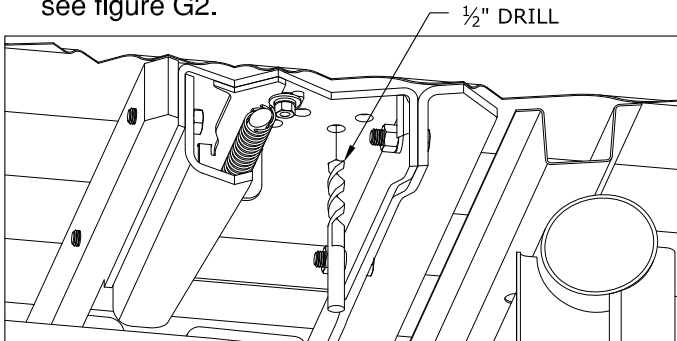

FIGURE G2: Cut away view of bed and center section

- 2. Install the U-bolts.** From the top side of the truck bed, drop a u-bolt in each set of holes.
- 3. Add springs.** Place a conical spring over each leg of the u-bolts and secure with a $\frac{1}{2}$ " lock nut, see figure G3. Tighten the lock nut until the nut is flush with the end of the u-bolt.

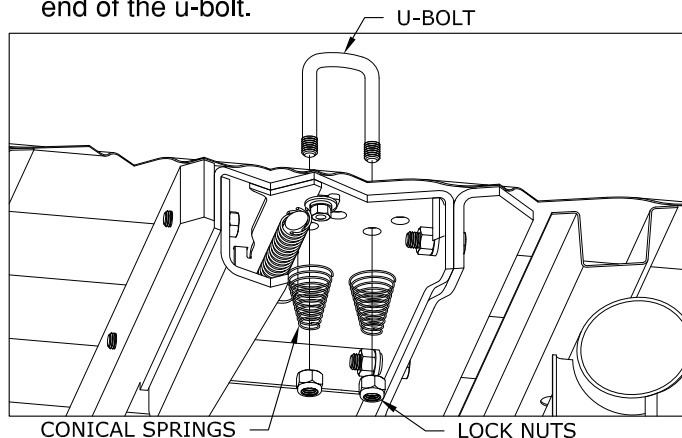

FIGURE G3: Cut away view of bed and center section

PREPARE FOR TOWING

- 1. Replace spare tire.** If the spare tire was removed prior to installing the hitch, replace it at this time.
- 2. Modify fender liner.** If a fender liner is present that restricts the movement of the handle, it is recommended that it be modified by cutting a relief slot or hole to allow the handle to move freely. If the liner was removed for installation, reinstall at this time.
- 3. Retract the pin.** Pull the handle out all the way until it stops then rotate it clockwise. The handle should stay in this position. The latch should only be put in this "open" position when inverting the 2-5/16 ball or installing a B&W towing accessory.

⚠ Operating the tow vehicle while the latch is in the open position may allow the handle to come into contact with the rear tire. This may damage the tire or the handle, and could lead to serious injury or death.

- 4. Lubricate 2-5/16 ball.** Apply a light coating of grease to the four corners on the square shank of the 2-5/16 ball.
- 5. Engage pin.** Rotate the handle counter clockwise until the handle retracts and engages the 2-5/16 ball.

⚠ When installed properly the latch pin will pass through the 2-5/16 ball and fully engage through both walls of the hitch receiver. Failure of the pin to engage the ball and hitch properly could result in a loss of attachment between the trailer and the tow vehicle.

OPERATION & MAINTENANCE

- Always be sure that latch pin is fully engaged in the socket before towing.
- Inspect hardware connections before towing to be sure that they are secure.
- Measure and determine turning clearance with the cab before towing unfamiliar trailers. Additional products for increasing turning clearance are available from B&W.
- When inverting the ball, inspect the ball's relationship with the truck's differential and drive line to ensure proper clearance. **DO NOT INVERT THE BALL WHEN HAULING HEAVY LOADS ON 2 WHEEL DRIVE TRUCKS.** A plug for the socket is available from B&W so that the ball may be removed and the socket may be covered when hauling heavy loads.
- Periodically grease the corners on the square shank of the 2-5/16 ball.